

**TECHNICAL BULLETIN
INSTALLATION INSTRUCTIONS**

FOR SYSTEMS

**SINGLE CHANNEL GROUND AND
AIRBORNE RADIO SYSTEM (SINGARS)
AN/VRC-88F, AN/VRC-89F, AN/VRC-90F, AN/VRC-91F, AN/VRC-92F**

**FORCE XXI BATTLE COMMAND, BRIGADE-AND-BELOW (FBCB2)
AN/UYK-128(V)**

**DEFENSE ADVANCED GPS RECEIVER (DAGR)
AN/PSN-13**

**VEHICULAR INTERCOMMUNICATION SET (VIS)
AN/VIC-3(V)20**

BLUE FORCE TRACKING (BFT)

**ENHANCED POSITION LOCATION REPORTING SYSTEM (EPLRS)
AN/VSQ-2(V)**

FOR VEHICLE

**TRUCK, UTILITY: COMMAND AND CONTROL/GENERAL PURPOSE VEHICLE,
IAP ARMOR READY, M1165A1 (2320-01-540-2017)**

DISTRIBUTION STATEMENT A: Approved for public release; distribution is unlimited.

HEADQUARTERS, DEPARTMENT OF THE ARMY

OCTOBER 2007

LIST OF EFFECTIVE PAGES

NOTE

A vertical line in the outer margins of the page indicates the portion of text affected by the change.

Dates of issue for original and change pages are:

Original 0 31 October 2007

TOTAL NUMBER OF PAGES IN THIS PUBLICATION IS 118 PAGES.

Page No.	*Change No.
i-iii/iv (blank)	0
1-1 – 5-102	0

*Zero in this column indicates original page.

**TECHNICAL BULLETIN
INSTALLATION INSTRUCTIONS**

FOR SYSTEMS

**SINGLE CHANNEL GROUND AND
AIRBORNE RADIO SYSTEM (SINCGARS)**

**AN/VRC-88F, AN/VRC-89F, AN/VRC-90F,
AN/VRC-91F, AN/VRC-92F**

**FORCE XXI BATTLE COMMAND, BRIGADE-AND-BELOW (FBCB2)
AN/UJK-128(V)**

**DEFENSE ADVANCED GPS RECEIVER (DAGR)
AN/PSN-13**

**VEHICULAR INTERCOMMUNICATION SET (VIS)
AN/VIC-3(V)20**

BLUE FORCE TRACKING (BFT)

**ENHANCED POSITION LOCATION REPORTING SYSTEM (EPLRS)
AN/VSQ-2(V)**

FOR VEHICLE

**TRUCK, UTILITY: COMMAND AND CONTROL/GENERAL PURPOSE VEHICLE,
IAP ARMOR READY, M1165A1 (2320-01-540-2017)**

REPORTING ERRORS AND RECOMMENDING IMPROVEMENTS

You can help improve this publication. If you find any mistakes or if you know of a way to improve the procedures, please let us know. Submit your DA Form 2028 (Recommended Changes to Publications and Blank Forms), through the Internet, on the Army Electronic Product Support (AEPS) website. The Internet address is <http://aeps.ria.army.mil>. If you need a password, scroll down and click on "ACCESS REQUEST FORM." The DA Form 2028 is located in the ONLINE FORMS PROCESSING section of the AEPS. Fill out the form and click on SUBMIT. Using this form on the AEPS will enable us to respond quicker to your comments and better manage the DA Form 2028 program. You may also mail, fax, or E-mail your letter or DA Form 2028 direct to: TACOM Life Cycle Management Command, ATTN: AMSTA-LC-LMPP/TECH PUBS, 1 Rock Island Arsenal, Rock Island, IL 61299-7630. The E-mail address is ROCK-TACOM-TECH-PUBS@conus.army.mil. The fax number is DSN 793-0726 or Commercial (309-0726).

TABLE OF CONTENTS

		Page
	LIST OF TABLES	iii
CHAPTER 1.	INTRODUCTION	1-1
Section I.	Scope	1-1
Section II.	Notes	1-1
Section III.	General Information	1-1
Section IV.	Maintenance Forms, Records, and Reports	1-1
Section V.	Consolidated Index of Army Publications	1-1
CHAPTER 2.	PURPOSE OF INSTALLATION	2-1
CHAPTER 3.	COMPLETION TIME FOR INSTALLATION	3-1
CHAPTER 4.	PREPARATION FOR INSTALLATION	4-1
Section I.	Preparation of Vehicle	4-1
Section II.	Items to be Removed	4-1
Section III.	List of Items to be Retained	4-1
Section IV.	Preparation of C4ISR Equipment	4-1
Section V.	Precautions During Handling	4-1
Section VI.	Unpack and Inspect Equipment	4-1
Section VII.	Inventory C4ISR Equipment	4-1
Section VIII.	Examine Each Item for Damage	4-1
Section IX.	C4ISR Equipment, Distribution, and Consumables	4-2
Section X.	Distribution and Issue Instructions	4-2
Section XI.	Parts List	4-2
CHAPTER 5.	INSTALLATION PROCEDURES	5-1
Section I.	Scope	5-1
Section II.	Integrated Rack Installation	5-1
Section III.	SINGARS Mounting Tray, Amp Guard, and FBCB2 Components Installation	5-15
Section IV.	DAGR Installation	5-27
Section V.	BFT Installation	5-39
Section VI.	Interface Plate Installation	5-46
Section VII.	EPLRS Resilient Mount Installation	5-48
Section VIII.	URO Mounting Bracket Installation	5-50
Section IX.	EPLRS Antenna Installation	5-51
Section X.	EPLRS Cables Installation	5-54
Section XI.	SINGARS Antenna Installation	5-72
Section XII.	SINGARS Cables Installation	5-75
Section XIII.	VIC-3 Mounting Installation: FFCS/L	5-81
Section XIV.	DAGR Power Cable Routing	5-98

LIST OF TABLES

Table	Title	Page
4-1.	Kits Parts List for Installation of C4ISR Equipment	4-3
4-2.	Non-Kit Parts List for Installation of C4ISR Equipment	4-5

CHAPTER 1

INTRODUCTION

Section I. SCOPE

- 1-1.** This technical bulletin provides installation instructions for Command, Control, Communications, Computers, Intelligence, Surveillance, and Reconnaissance (C4ISR) equipment. The C4ISR equipment shall be installed in the following vehicles:
- Truck, Utility: Command and Control/General Purpose Vehicle, IAP Armor Ready, M1165A1.
- 1-2.** The information contained in this technical bulletin is the official authorization to perform the installation of the C4ISR equipment at the direct support maintenance level through contract maintenance teams.

Section II. NOTES

- 2-1.** This technical bulletin is not an authorization for requisition or turn-in of vehicles.
- 2-2.** This technical bulletin does not establish quantity or types of vehicles assigned to using units.

Section III. GENERAL INFORMATION

- 3-1.** Included in the C4ISR equipment are:
- a. Single Channel Ground and Airborne Radio System (SINCGARS), AN/VRC-88F/89F/90F/91F/92F Series
 - b. Force XXI Battle Command, Brigade-and-Below (FBCB2), AN/UYK-128(V)
 - c. Defense Advanced GPS Receiver (DAGR), AN/PSN-13
 - d. Vehicular Intercommunication Set (VIS), AN/VIC-3(V)20
 - e. Blue Force Tracking (BFT)
 - f. Enhanced Position Location Reporting System (EPLRS) AN/VSQ-2(V)
- 3-2.** The C4ISR equipment becomes operable when all the components are installed in the vehicle and correct power is supplied.

Section IV. MAINTENANCE FORMS, RECORDS, AND REPORTS

Use the following to report any discrepancies:

- a. Reports of Maintenance and Unsatisfactory Equipment. See chapter 4, sections VI through VIII for information.
- b. Report of Packaging and Handling Deficiencies. See chapter 4, sections VI through VIII for information.
- c. Discrepancy in Transportation Deficiency Report (TDR) (SF361). See chapter 4, sections VI through VIII for information.

Section V. CONSOLIDATED INDEX OF ARMY PUBLICATIONS

Refer to the latest issue of DA PAM 25-30 to determine whether there are new changes or additional publications pertaining to the C4ISR equipment.

CHAPTER 2

PURPOSE OF INSTALLATION

The purpose of installing the C4ISR equipment is to provide the primary means of integrating command and control capability.

CHAPTER 3

COMPLETION TIME FOR INSTALLATION

A total of 20 man hours are required for two personnel to install the C4ISR equipment. Typical vehicle downtime is 12 hours.

CHAPTER 4 PREPARATION FOR INSTALLATION

Section I. PREPARATION OF VEHICLE

To prepare the vehicle for installation, ensure that the site includes adequate lighting and a power source when drilling is required. Inspect the vehicle for damage that could affect installation. Have any such damage repaired before installing the C4ISR equipment.

Section II. ITEMS TO BE REMOVED

Remove batteries. (Refer to TM 9-2320-387-24.)

Section III. LIST OF ITEMS TO BE RETAINED

Batteries.

Section IV. PREPARATION OF C4ISR EQUIPMENT

To prepare C4ISR equipment, unpack, inspect, and check inventory.

Section V. PRECAUTIONS DURING HANDLING

Observe the following precautions to prevent equipment damage.

- a. Keep dust covers in place on connectors.
- b. Do not disassemble or modify parts in the C4ISR equipment unless authorized to do so.
- c. Keep mounting hardware covered and protected until needed.

Section VI. UNPACK AND INSPECT EQUIPMENT

- 6-1.** Unpack and inspect packaging for evidence of damage.
- 6-2.** Any shipping damage should be reported on SF364 Report of Discrepancy (ROD) as prescribed in AR 735-11-2/DLAR 4140.55/NAVMATINST 4355.73A/AFR 400-64/MCO 4430.F.

Section VII. INVENTORY C4ISR EQUIPMENT

If any item is missing, fill out and forward Transportation Deficiency Report (TDR) (SF361) as described in AR 55-38/NAVSUPINST 4610.33C/AFR 75-18/MCO P4610.19D/DLAR 450015.

Section VIII. EXAMINE EACH ITEM FOR DAMAGE

If any item is damaged, fill out and forward SF364 Report of Discrepancy (ROD) as prescribed in AR 735-11-2/DLAR 4140.55/NAVMATINST 4355.73A/AFR 400-64/MCO 4430.F. All damages should be reported as prescribed by DA PAM 750-8, as contained in the Maintenance Management Update.

Section IX. C4ISR EQUIPMENT, DISTRIBUTION, AND CONSUMABLES

- 9-1. Use table 4-1 to identify and inventory C4ISR equipment installation parts supplied in kits.
- 9-2. Use table 4-2 to identify and inventory C4ISR equipment installation parts not supplied in kits.

Section X. DISTRIBUTION AND ISSUE INSTRUCTIONS

- 10-1. U.S. Forces: Do not requisition C4ISR equipment. They will be shipped automatically.
- 10-2. U.S. Army Depots: Requisition C4ISR equipment through supply channels.
- 10-3. Multiservice: Instructions shall be included for multiservice modifications.
- 10-4. MAP/MAS countries: Instructions shall be provided for MAP/MAS countries.

Section XI. PARTS LIST

KITS REQUIRED FOR THIS INSTALLATION:

NOTE

- Not all material in kits is required for this installation. Material not used during installation will be returned to stock for disposition in accordance with AR 725-50.
- If maintenance is to be performed on a vehicle with an existing kit, do not order entire kit for necessary reinstallation.

SINGARS:

(A): MK-2801

DAGR:

(B): 57K4886

FBCB2:

(D): No kits available

VIS:

(E): 6500729

BFT:

(F): No kits available

EPLRS:

(G): No kits available

MATERIAL REQUIRED FROM KITS:*Table 4-1. Kit Parts List for Installation of C4ISR Equipment.*

ITEM NO.	NOMENCLATURE	PART NUMBER	NSN	KIT	QTY.
1.	Antenna, DAGR	013-1981-010	5985-01-502-6692	(B)	1
2.	Bracket, Antenna	A3014546-1	5340-01-391-2742	(A)	2
3.	Bracket, Mounting	12506679	—	(B)	1
4.	Cable Assembly	A3206018-2	5995-01-392-6196	(E)	1
5.	Cable Assembly	A3206018-6	5995-01-392-6197	(E)	1
6.	Cable Assembly	A3206017-3	5995-01-452-4309	(E)	1
7.	Cable Assembly	A3206019-3	5995-01-458-5334	(E)	1
8.	Cable Assembly, Antenna DAGR	987-5016-001	5995-01-521-4244	(B)	1
9.	Cable Assembly, Antenna DAGR	987-4640-001	5995-01-504-1762	(B)	1
10.	Cable Assembly, Radio Frequency	A3014031-8	5995-01-219-7035	(A)	1
11.	Cable Assembly, Radio Frequency	A3014031-17	5995-01-225-1660	(A)	1
12.	Cable, Highway	A3206018-9	5995-01-406-1172	(E)	1
13.	Cable, Highway	A3206018-12	5995-01-392-6204	(E)	1
14.	Cable, Power	987-5019-001	6150-01-521-6757	(B)	1
15.	Capscrew	B1821BH025C100N	5305-00-225-3843	(E)	3
16.	Capscrew	B1821BH031C125N	5306-00-226-4829	(E)	4
17.	Capscrew	B1821BH031F125N	5305-00-051-4078	(E)	1
18.	Capscrew	MS35307-365	5305-00-847-1159	(A)	8
19.	Clamp, Loop	MS21333-76	5340-00-724-7038	(E)	3
20.	Clamp, Loop	MS21333-100	5340-00-809-1492	(E)	2
21.	Clamp, Loop	MS21333-97	5340-00-080-9853	(B)	1
22.	Clamp, Loop	MS21333-104	5340-00-088-1254	(E)	1
23.	Clamp, Loop	MS21333-105	5340-00-809-1494	(E)	1
24.	Clamp, Loop	MS21333-111	5340-00-057-3037	(E)	1
25.	Clamp, Loop	MS21333-112	5340-00-057-3043	(E)	1
26.	Clamp, Loop	MS21333-129	5340-00-151-9651	(B)	1
27.	DAGR AN/PSN-13	822-1873-001	5285-01-516-8038	(B)	1
28.	Full Function Control Station	A3206624	5895-01-469-6120	(E)	3
29.	Gasket	A3013655-1	5330-01-205-2864	(A)	2
30.	Master Control Station	A3206623	5895-01-469-3352	(E)	1
31.	Mount, Installation	987-5006-001	5975-01-521-3063	(B)	1
32.	Mounting Base, Electrical Equipment	A3013367-1	5975-01-188-8873	(A)	1
33.	Mounting Bracket, Left-Hand	6500695-1	N/A	(E)	1
34.	Mounting Bracket, Right-Hand	6500695-2	N/A	(E)	1
35.	Insert	12446871-3	5325-01-411-0066	(B)	2
36.	Nut	MS51967-6	5310-00-931-8167	(B)	1
37.	Nut	120376	5310-00-012-0376	(E)	5
38.	Nut, Lock	MS17829-3C	5310-00-689-3877	(B)	4

MATERIAL REQUIRED FROM KITS:

Table 4-1. Kit Parts List for Installation of C4ISR Equipment (Contd).

ITEM NO.	NOMENCLATURE	PART NUMBER	NSN	KIT	QTY.
39.	Screw, Machine	MS35206-263	5305-00-984-6210	(B)	4
40.	Screw, Machine	MS35206-267	5305-00-984-6214	(B)	2
41.	Screw, Machine	MS35207-261	5305-00-990-6444	(B)	1
42.	Support	12506676	—	(B)	1
43.	Terminal Lug	7728777	5940-00-983-4067	(B)	1
44.	Terminal Lug	7728780	5940-01-035-4212	(B)	1
45.	Tie-Down Strap	MS3367-1-0	5975-00-984-6582	(E)	4
46.	Tie-Down Strap	MS3367-7-0	5975-01-034-5871	(E)	1
47.	Tubing, Shrink	MS23054/4-103-0	—	(B)	3 in.
48.	Washer	10910174-19	5310-00-964-3415	(E)	4
49.	Washer	2436162	5310-01-119-1024	(E)	7
50.	Washer, Lock	MS35338-43	5310-00-045-3296	(B)	5
51.	Washer, Lock	MS35338-44	5310-00-582-5965	(A), (E)	16
52.	Washer, Lock	MS45904-72	5310-00-889-2527	(A)	6
53.	Washer, Lock	120214	5310-00-012-0214	(E)	6

MATERIAL REQUIRED BUT NOT INCLUDED IN KITS:*Table 4-2. Non-Kit Parts List for Installation of C4ISR Equipment.*

ITEM NO.	NOMENCLATURE	PART NUMBER	NSN	QTY.
1.	Antenna Base	A3017899-2	5985-01-308-8988	2
2.	Antenna, AS-3499/VSQ-1	A3005031	5985-01-183-9462	1
3.	Antenna, Element (lower)	A3018230-1	5985-01-306-8110	2
4.	Antenna, Element (upper)	A3017901-2	5985-01-306-4622	2
5.	Anti-seize	12Z31001-1	8030-00-292-1102	A/R
6.	Assembly, Display Lock	872843-1	N/A	1
7.	Bar, Locking	—	—	1
8.	Bolt	MS35751-18	5306-00-108-9988	4
9.	Box, Stowage	889519-1	2540-01-499-0607	1
10.	Bracket, Antenna Base Reinforcement	A3046241	5340-01-262-9560	1
11.	Bracket, Locking	—	—	1
12.	Bracket, Mounting	A3046238	5975-01-277-7854	1
13.	Bracket, Mounting	889567-14	—	1
14.	Bracket Transceiver	A1-38239D	—	1
15.	Bracket, User-Readout	A3006206	5340-01-386-7841	1
16.	Cable Assembly, INC-EPUU	A3279383-3	5995-01-453-9171	1
17.	Cable, EPLRS Power	A3004939	5995-01-198-0538	1
18.	Cable, EPLRS Antenna	SM-C-911480	5995-01-167-1269	1
19.	Cable, Transceiver	A1-35997D	5995-01-531-2166	1
20.	Cable, URO	A3109227	5995-01-417-8085	1
21.	Cable, W3N	881336-1	5995-01-478-4913	1
22.	Cable, W3P	881335-1	5995-01-478-4891	1
23.	Clamp, Loop	MS21333-68	5340-00-843-7825	5
24.	Clamp, Loop	MS21333-72	5340-00-091-3790	2
25.	Clamp, Loop	MS21333-98	5340-00-809-1490	3
26.	Clamp, Loop	MS21333-99	5340-00-993-6207	1
27.	Clamp, Loop	MS21333-101	5340-00-088-6655	4
28.	Clamp, Loop	MS21333-102	5340-00-984-8540	2
29.	Clamp, Loop	MS21333-104	5340-00-088-1254	5
30.	Clamp, Loop	MS21333-108	5340-00-057-3025	2
31.	Clamp, Loop	MS21333-110	5340-00-057-3034	2
32.	Clamp, Loop	MS21333-111	5340-00-057-3037	2
33.	Clamp, Loop	MS21333-112	5340-00-057-3043	2
34.	CPU	881292-1	7021-01-474-3793	1
35.	Decal	861868-2	N/A	1
36.	Display	881293-1	7025-01-475-0229	1
37.	EPLRS AN/VSQ-2(V)	—	—	1
38.	Footrest Weldment	889567-21	N/A	1
39.	Gasket	A3013655-1	5330-01-205-2864	1
40.	Grommet, Nonmetallic	12338098	5325-01-208-5424	2
41.	Grommet, Nonmetallic	MS21266-6N	5325-00-783-4753	3 in.
42.	Grommet, Nonmetallic	MS21266-5N	5325-00-783-4754	3 in.

MATERIAL REQUIRED BUT NOT INCLUDED IN KITS (Contd):*Table 4-2. Non-Kit Parts List for Installation of CAISR Equipment (Contd).*

ITEM NO.	NOMENCLATURE	PART NUMBER	NSN	QTY.
43.	Grommet, Nonmetallic	MS35489-27	5325-00-290-1960	1
44.	Guard, Amp	872842-1	5935-01-487-2172	1
45.	Insert	12446871-3	5325-01-411-0066	2
46.	Insert	12446871-5	5325-01-483-7480	3
47.	Insert	12446871-7	5325-01-475-9697	4
48.	Insert	12446871-15	5325-01-535-5501	4
49.	Insert	12446871-16	N/A	8
50.	Integrated Rack	889509-1	—	1
51.	Isolation Kit, CPU	872826-2	5340-01-481-5741	1
52.	Isolation Kit, Display	872870-1	5340-01-481-5757	1
53.	Keyboard	501395-1	—	1
54.	Lanyard	8925T5-7X19	4010-01-497-2675	1
55.	Left Rail Weldment	889567-12	N/A	1
56.	Mount, Ramball	RAM-D-111-MAU	5975-01-485-3615	1
57.	Mount, Resilient	MT-6146/VSQ-1	5340-01-167-8297	1
58.	Nut	120376	—	4
59.	Nut	MS35649-2252	5310-00-997-1888	4
60.	Nut	13218E0320-293	5310-00-913-8881	12
61.	Nut	9418892	5310-01-157-9819	8
62.	Nut	120361	—	1
63.	Nut	9419143	5310-01-148-0240	10
64.	Nut, Lock	271169	5310-00-124-9265	2
65.	Nut, Lock	271166	5310-00-696-5172	1
66.	Nut, Lock	271172	5310-01-152-0598	2
67.	Nut, Lock	271175	5310-01-333-5245	2
68.	Nut, Lock	271178	5310-01-407-7198	1
69.	Nut, Lock	9422279	5310-01-462-4393	1
70.	Nut, Lock	M45913/4-4CG8Z	5310-01-548-1269	3
71.	Nut, Lock	M45913/4-5CG8Z	—	1
72.	Padlock	—	—	1
73.	Plate, Interface	—	—	1
74.	Rack Support	889509-22	N/A	1
75.	Right Rail Weldment	889567-22	N/A	1
76.	Rod	889567-16	N/A	1
77.	Screw, Cap	B1821BH025C075N	5305-00-068-0508	5
78.	Screw, Cap	B1821BH031F100N	5305-00-051-4076	2
79.	Screw, Cap	B1821BH031C100N	5306-00-226-4827	5
80.	Screw, Cap	B1821BH031F125N	5305-00-051-4078	8
81.	Screw, Cap	B1821BH025C150N	5305-00-071-2509	2
82.	Screw, Cap	B1821BH025C100N	5305-00-225-3843	6
83.	Screw, Cap	B1821BH025C088N	5305-00-071-2505	7
84.	Screw, Cap	B1821BH025C125N	5305-00-068-0509	11

MATERIAL REQUIRED BUT NOT INCLUDED IN KITS (Contd):*Table 4-2. Non-Kit Parts List for Installation of CAISR Equipment (Contd).*

ITEM NO.	NOMENCLATURE	PART NUMBER	NSN	QTY.
85.	Screw, Cap	B1821BH025C200N	5305-00-071-2511	5
86.	Screw, Cap	B1821BH038C150N	5305-00-725-2317	4
87.	Screw, Cap	B1821BH038C200N	5305-00-782-9489	3
88.	Screw, Cap	MS35206-266	5305-00-984-6213	5
89.	Screw, Machine	MS35190-287	5305-00-954-4295	2
90.	Screw, Machine	MS35190-291	5305-00-958-5247	2
91.	Screw, Machine	—	—	4
92.	Screw, Machine	MS24667-35	5305-00-968-3514	8
93.	Screw, Machine	MS35206-267	5310-00-984-6214	1
94.	Screw, Machine	MS35207-263	5305-00-989-7434	2
95.	Screw, Self-Tapping	12342499-2	5305-01-264-5809	1
96.	Screw, Self-Tapping	9421073	5305-01-162-8512	4
97.	Serial Interface Adapter Device	881331-1	4920-01-478-3722	1
98.	Spacer	10705AL315C	5365-01-487-3145	4
99.	Spacer	51506-8070R	N/A	3
100.	Spacer	51506-8097R	—	3
101.	Strap, Tiedown	MS3367-1-0	5975-00-984-6582	A/R
102.	Spiral Wrap	11644992	9330-01-038-3486	56 in.
103.	Switch Box Assembly	A1-36044D	—	1
104.	Tape, Electrical	HH-I-595-A-108-0	5970-00-926-7219	A/R
105.	Terminal Lug	MS20659-108	5940-00-115-2674	2
106.	Terminal Lug	MS20659-141	5940-00-113-9825	2
107.	Terminal Lug	7728777	5940-00-983-4067	1
108.	Terminal Lug	7728780	5940-01-035-4212	1
109.	Transceiver	MT2010E	—	1
110.	Tubing, Shrink	MS23053/4-103-0	N/A	3 in.
111.	Washer	2436161	5310-01-102-3270	25
112.	Washer	MS27183-10	5310-00-809-4058	21
113.	Washer	MS27183-13	—	3
114.	Washer	9416128	5310-00-402-2778	6
115.	Washer	MS27183-47	5310-01-312-4959	2
116.	Washer	10910174-19	5310-00-964-3415	4
117.	Washer	12338095	5310-01-208-7576	6
118.	Washer	MS51412-23	5310-01-333-0060	3
119.	Washer	—	—	4
120.	Washer, Lock	MS35338-43	5310-00-045-3296	8
121.	Washer, Lock	MS35338-44	5310-00-582-5965	38
122.	Washer, Lock	MS35338-45	5310-00-407-9566	6
123.	Washer, Lock	MS35338-46	5310-00-637-9541	22
124.	Washer, Lock	MS45904-69	5310-00-067-6357	5
125.	Washer, Lock	MS45904-71	5310-00-947-6980	1
126.	Washer, Lock	MS45904-72	5310-00-889-2527	10

MATERIAL REQUIRED BUT NOT INCLUDED IN KITS (Contd):

Table 4-2. Non-Kit Parts List for Installation of C4ISR Equipment (Contd).

ITEM NO.	NOMENCLATURE	PART NUMBER	NSN	QTY.
127.	Washer, Lock	MS45904-76	5310-00-061-1258	24
128.	Washer, Lock	—	—	4
129.	Wingnut	MS51553-420	5310-01-384-2546	4
130.	Wire, Braided	AA59569F30T0375	6145-00-191-8402	A/R
131.	Wire, Lock	MS20995C32	9505-00-293-4208	A/R

CHAPTER 5 INSTALLATION PROCEDURES

Section I. SCOPE

This chapter provides instructions for installation of the following C4ISR equipment:

- Single Channel Ground and Airborne Radio System (SINCGARS)
- Defense Advanced Global Positioning System Receiver (DAGR)
- Vehicular Intercommunications Set (VIS)
- Force XXI Battle Command, Brigade-and-Below (FBCB2)
- Blue Force Tracking (BFT)
- Enhanced Position Location Reporting System (EPLRS)

Perform the steps in this chapter when installing SINCGARS, DAGR, VIS, FBCB2, BFT, and EPLRS. When installing C4ISR equipment, be sure to read and follow instructions and illustrations carefully.

Section II. INTEGRATED RACK INSTALLATION

NOTE

- Mounting holes may already exist in tunnel insulation. If mounting holes exist, skip to step 2-18.
- Ensure existing rivet heads in tunnel floor are centered in the holes when finished drilling.
- Locate holes from support bracket, not front of insulation.

2-1. Locate, mark, and drill three 0.391-in. holes (1) in tunnel insulation (3).

2-2. Locate, mark, and drill three 0.531-in. holes (2) in tunnel insulation (3).

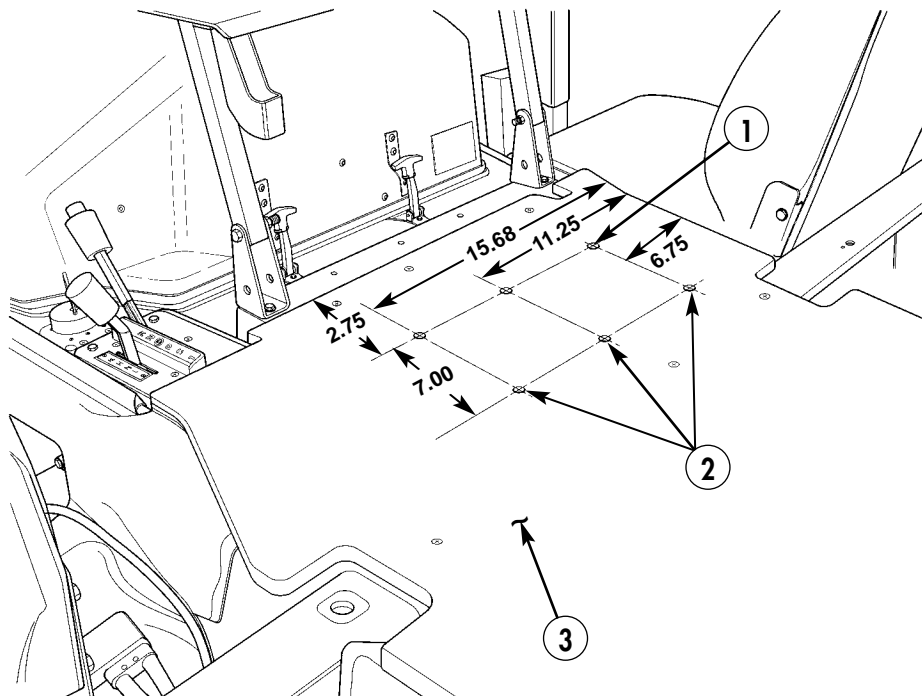

Figure 5-1.

- 2-3. Remove standard radio rack. (Refer to TM 9-2320-387-24.)
- 2-4. Remove eight screws (4), lockwashers (5), and washers (6) from air conditioning evaporator (7). Retain all hardware.
- 2-5. Disconnect A/C rear evaporator electrical cable (8) from air conditioning evaporator (7).

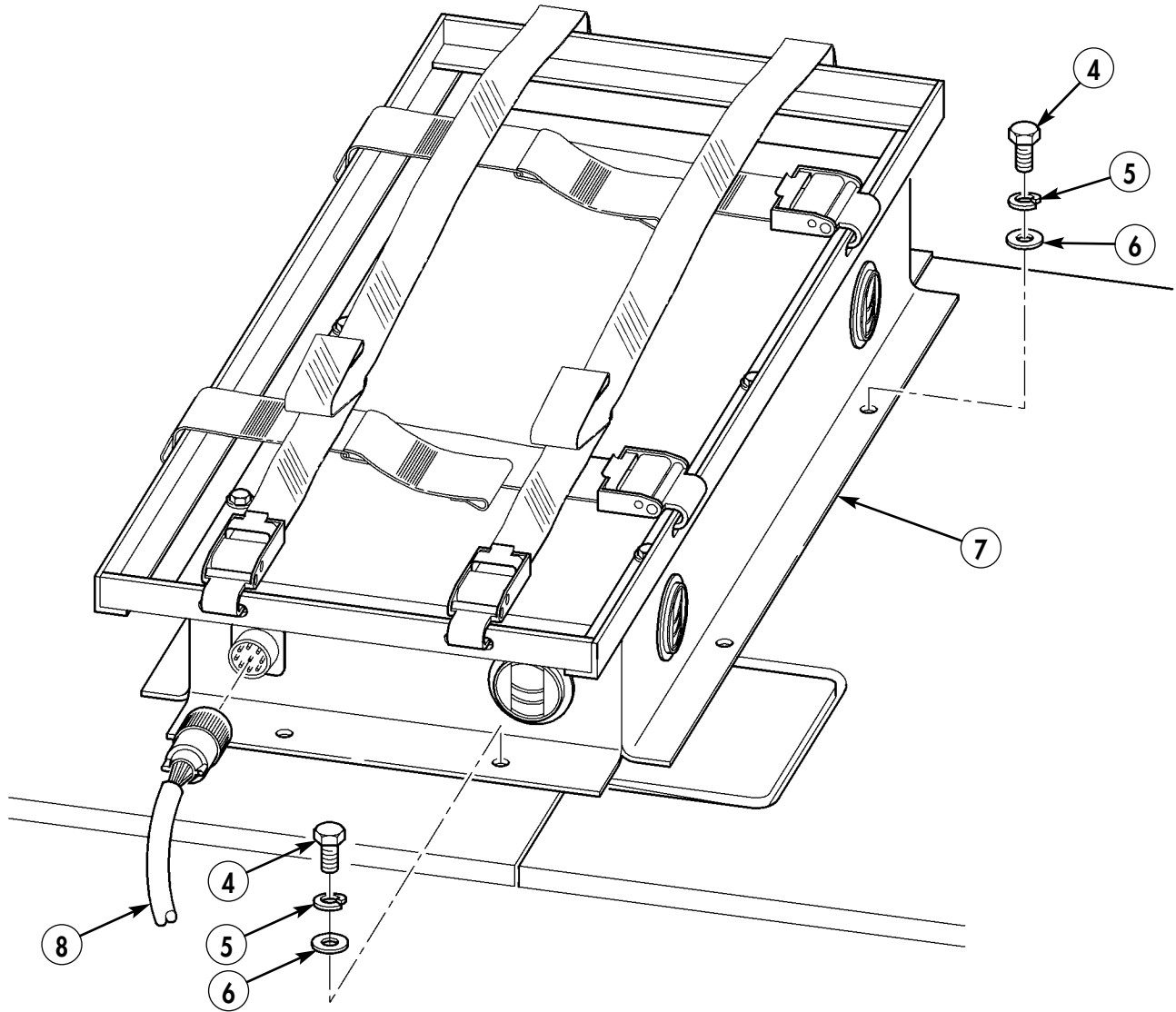

Figure 5-2.

2-6. Remove six screws (9) from tunnel insulation (3). Retain all hardware.

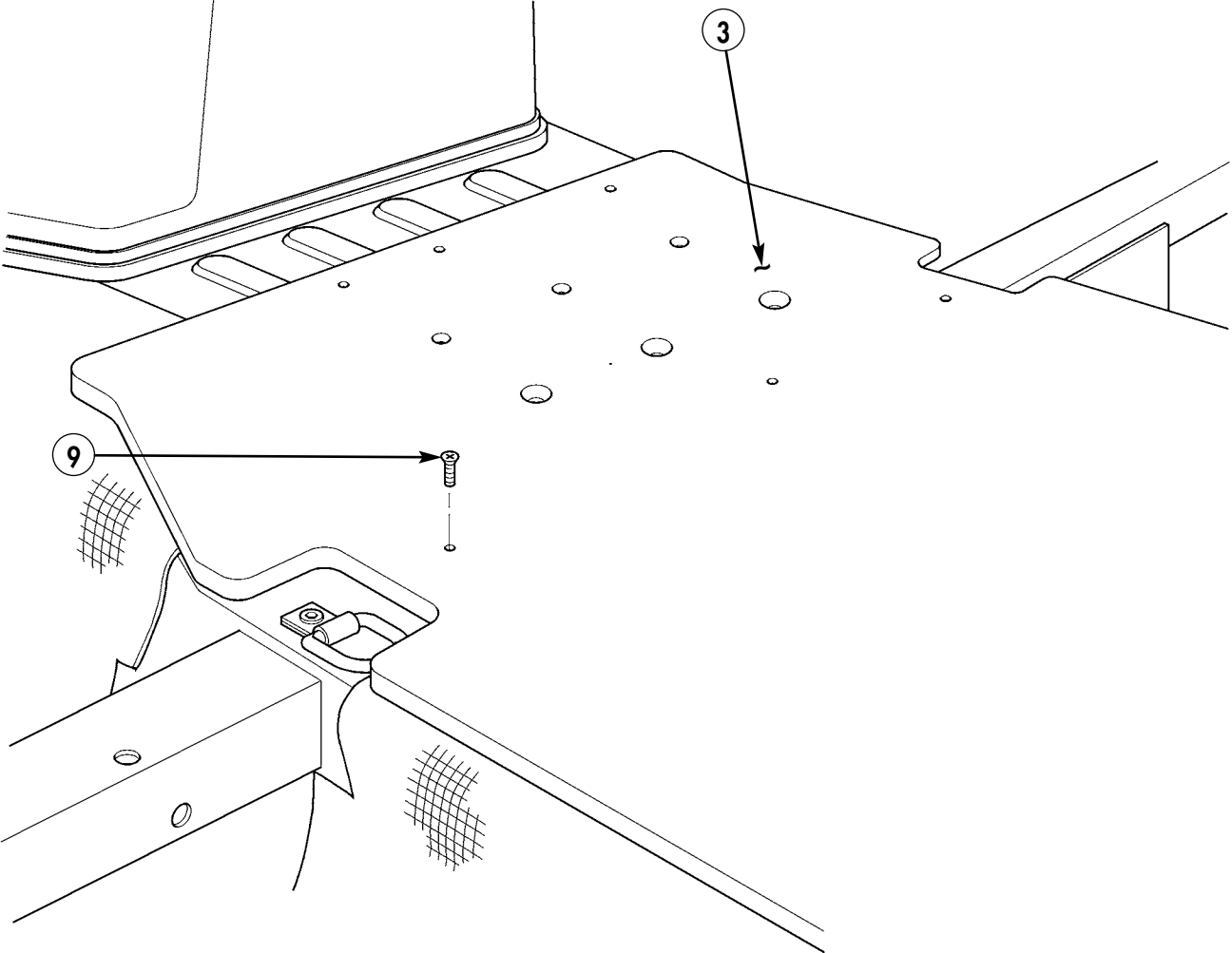

Figure 5-3.

CAUTION

Air conditioner hoses are still attached. Do not attempt to remove evaporator. Equipment damage may result.

2-7. Carefully lift air conditioning evaporator (7) and remove tunnel insulation (3).

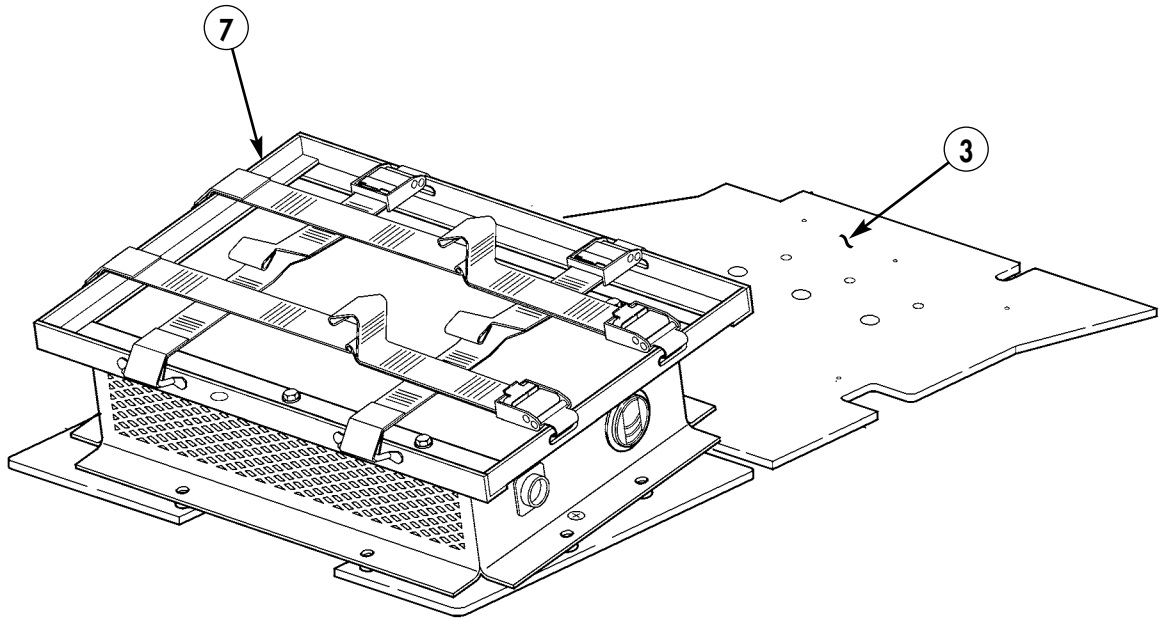
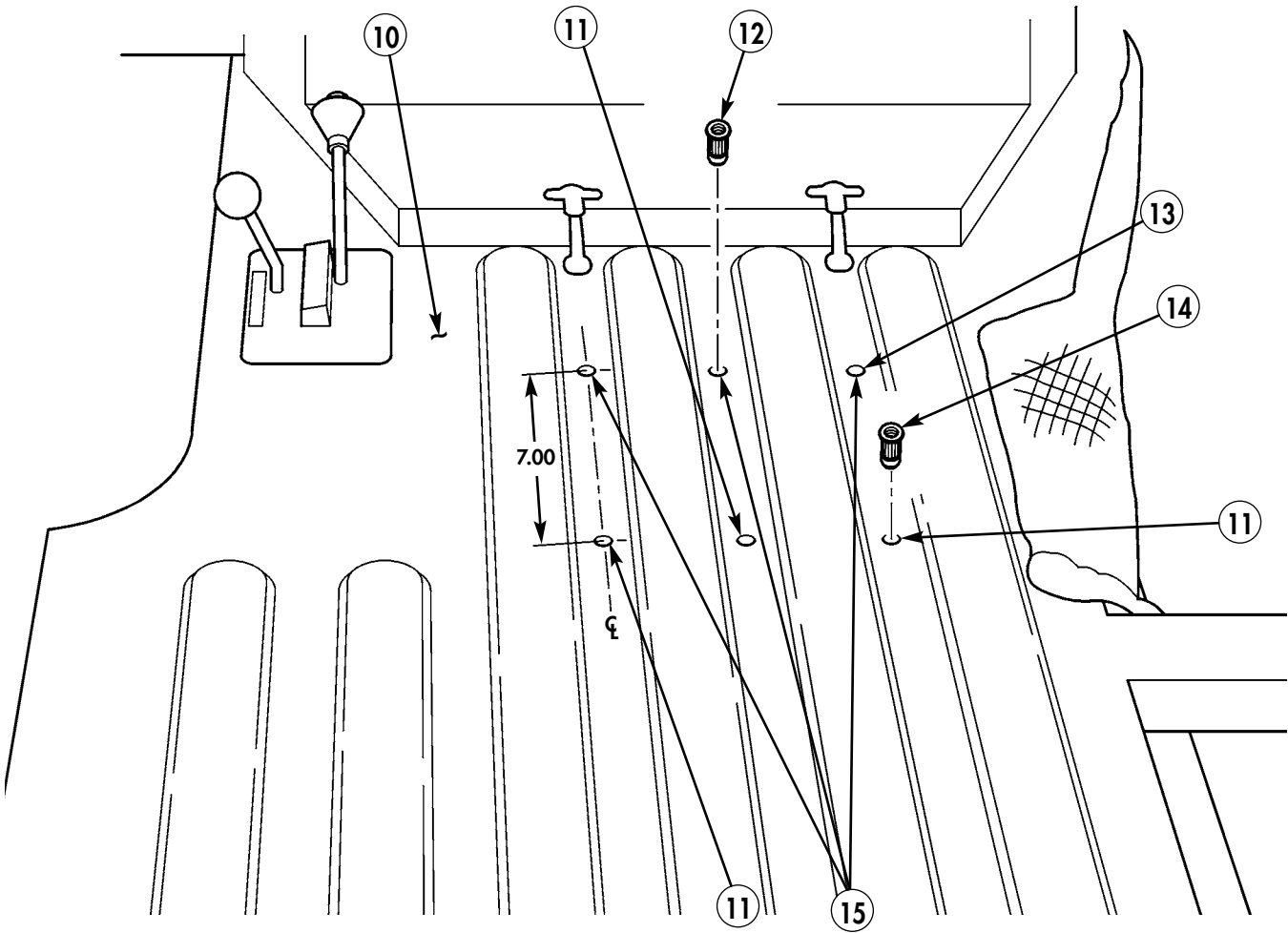

Figure 5-4.

NOTE

Perform steps 2-8 through 2-13 if inserts are not installed in tunnel floor.

- 2-8. Remove three existing rivets (13) from tunnel floor (10).
- 2-9. Locate and mark three holes (11) in tunnel floor (10).
- 2-10. Enlarge three holes (15) in tunnel floor (10) to 0.391-in.
- 2-11. Drill three 0.531-in. diameter holes (11) in tunnel floor (10).
- 2-12. Install three inserts (12) in tunnel floor (10).
- 2-13. Install three inserts (14) in tunnel floor (10).



- 12. INSERT - 12446871-16 - QTY. 3
- 14. INSERT - 12446871-5 - QTY. 3

Figure 5-5.

CAUTION

Air conditioner hoses are still attached. Do not attempt to remove evaporator. Equipment damage may result.

- 2-14. Carefully lift air conditioning evaporator (7) and install tunnel insulation (3) on tunnel floor (10).

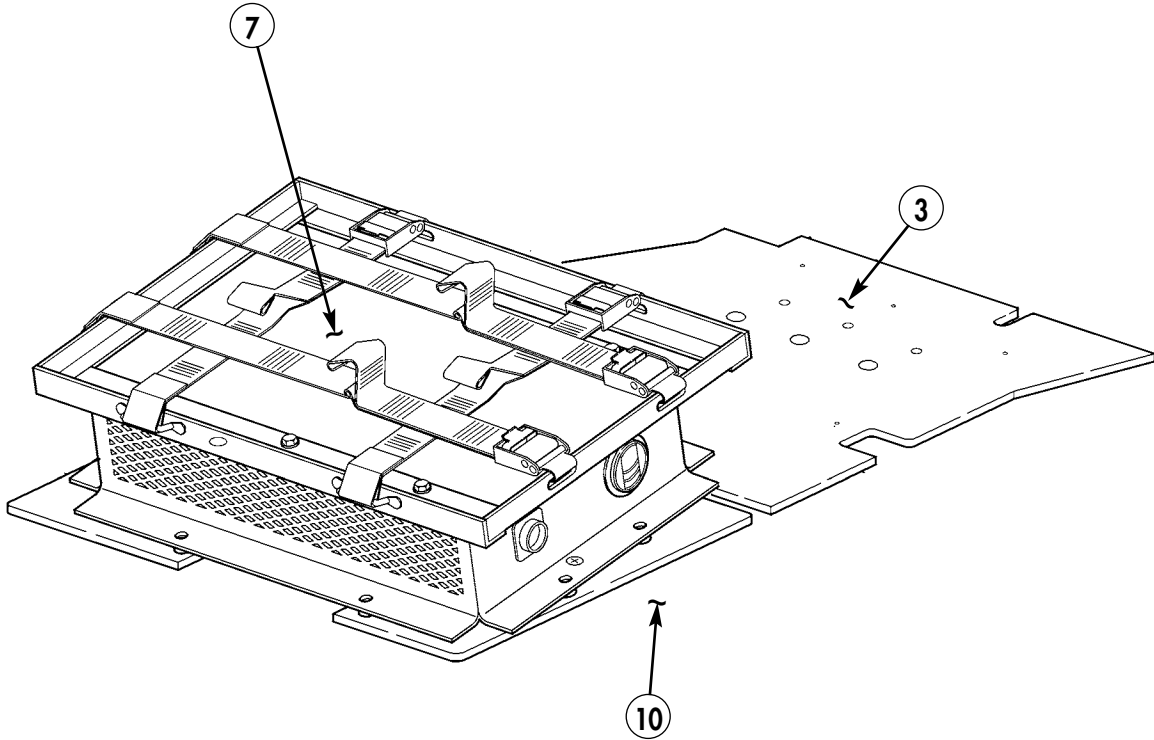

Figure 5-6.

2-15. Secure tunnel insulation (3) to tunnel floor (10) with six existing screws (9).

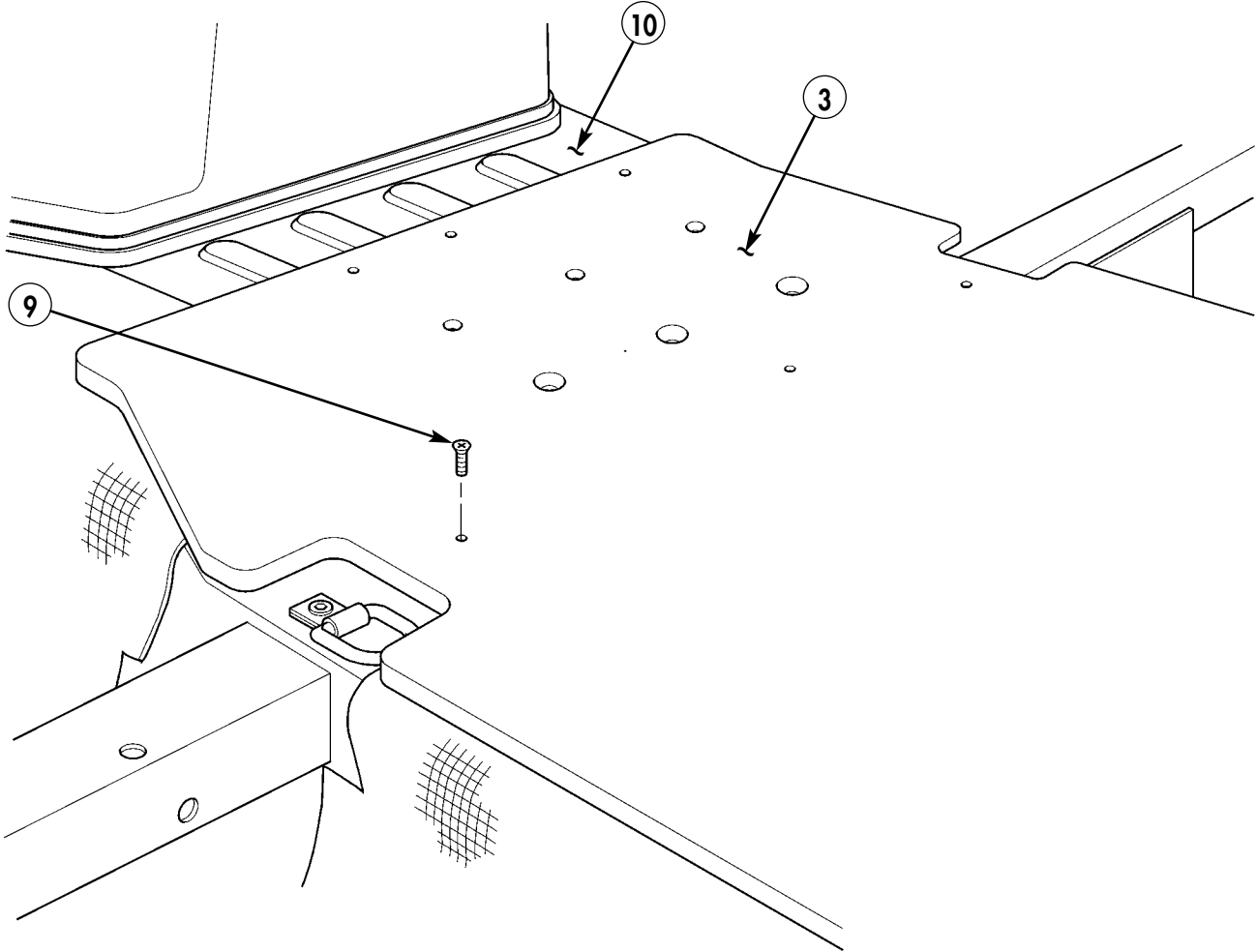
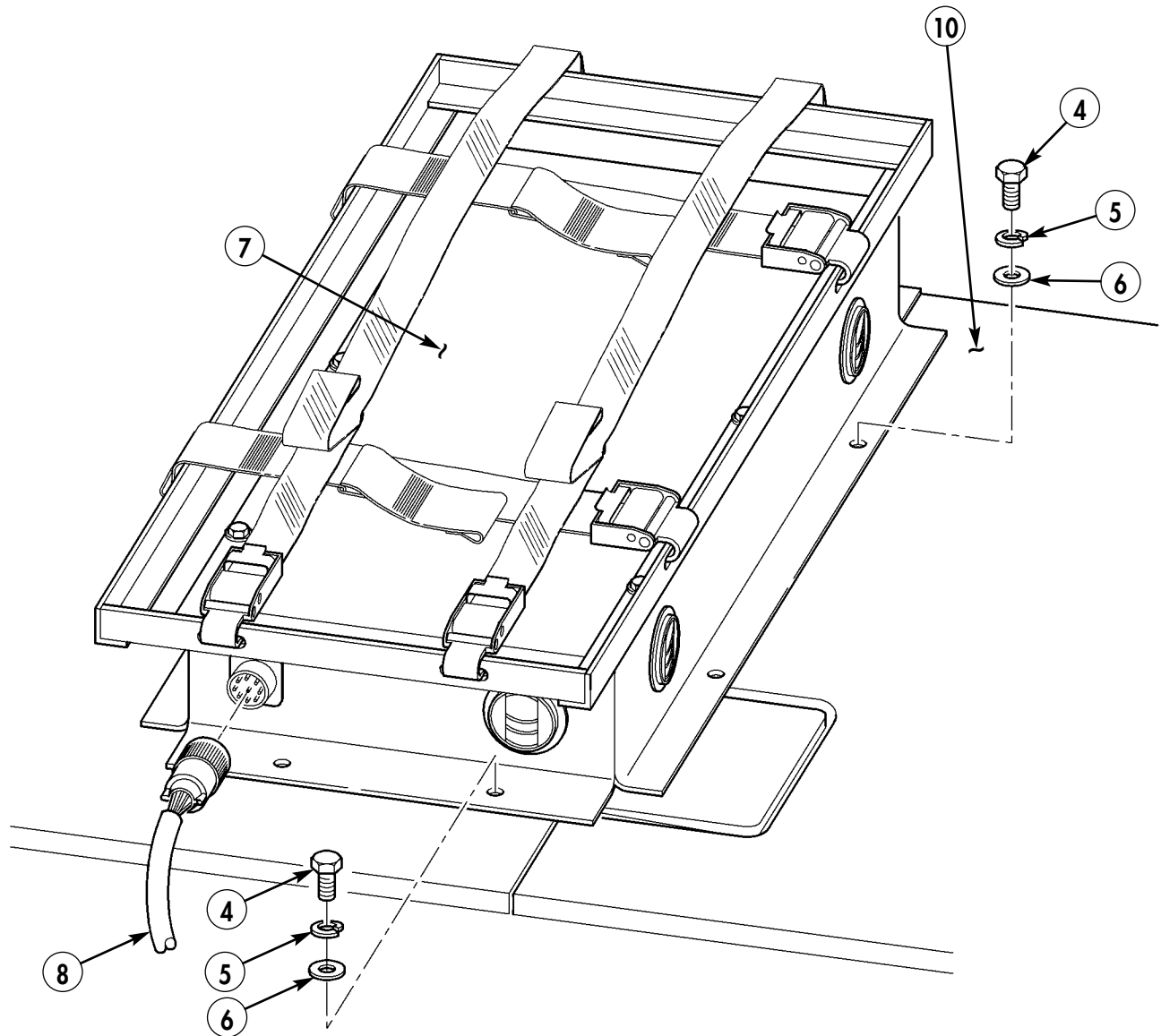

Figure 5-7.

- 2-16. Secure air conditioning evaporator (7) to tunnel floor (10) with eight existing screws (4), lockwashers (5), and washers (6).
- 2-17. Connect A/C rear evaporator electrical cable (8) to air conditioning evaporator (7).



5. LOCKWASHER – MS35338-44 – QTY. 8

Figure 5-8.

2-18. Install keyboard stowage box (17) on integrated rack (16) using four existing captive screws (18).

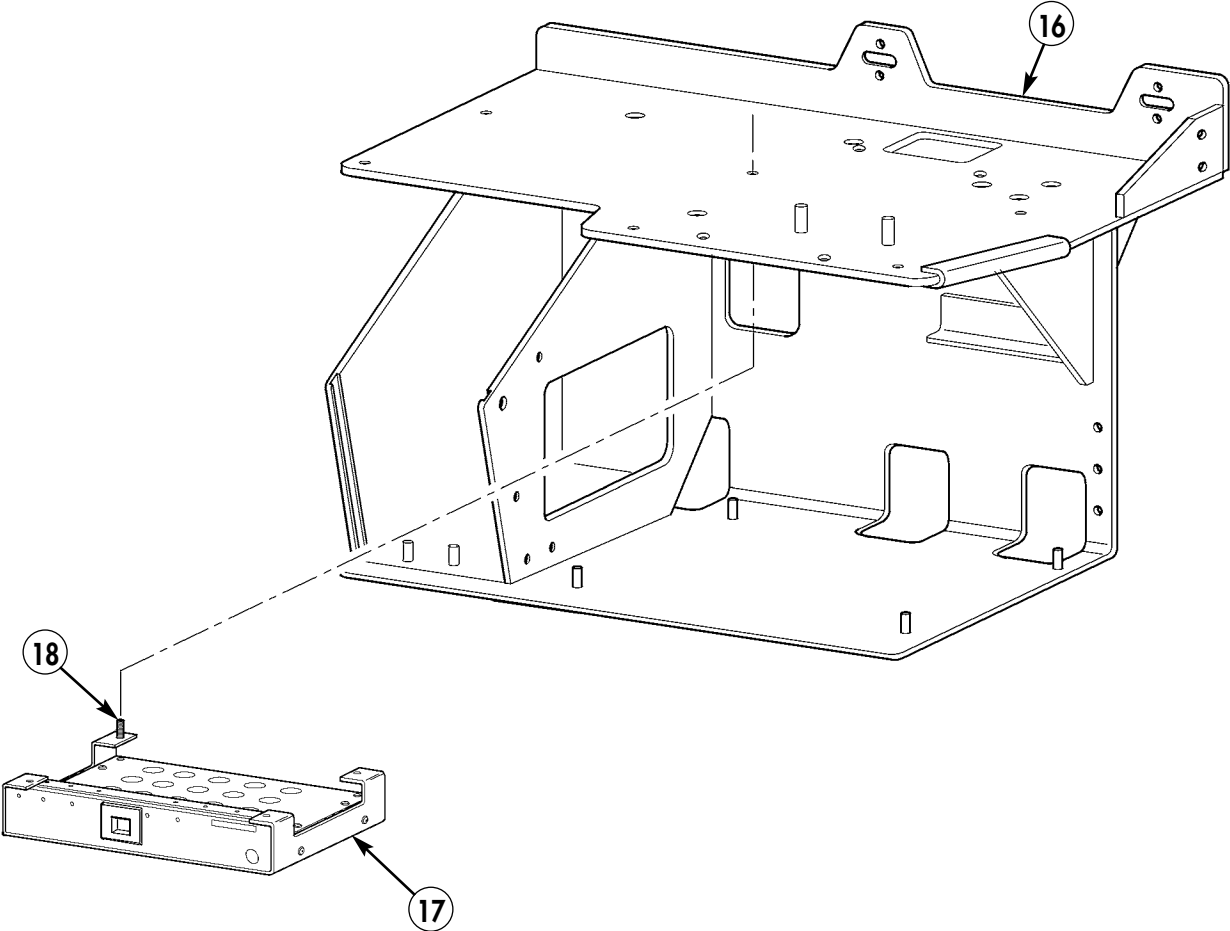

- 16. INTEGRATED RACK - 889509-1 - QTY. 1
- 17. KEYBOARD STOWAGE BOX - 889519-1 - QTY. 1

Figure 5-9.

NOTE

Install W3N cable if using BFT only.

- 2-19. Install W3N cable (22) to J1 connector (26) on Serial Interface Adapter Device (SIAD) (24).
- 2-20. Install W3P cable (23) to J2 connector (25) on SIAD (24). Route W3P cable (23) to DAGR.
- 2-21. Install SIAD (24) on integrated rack (16) using two screws (21), lockwashers (20), and washers (19).

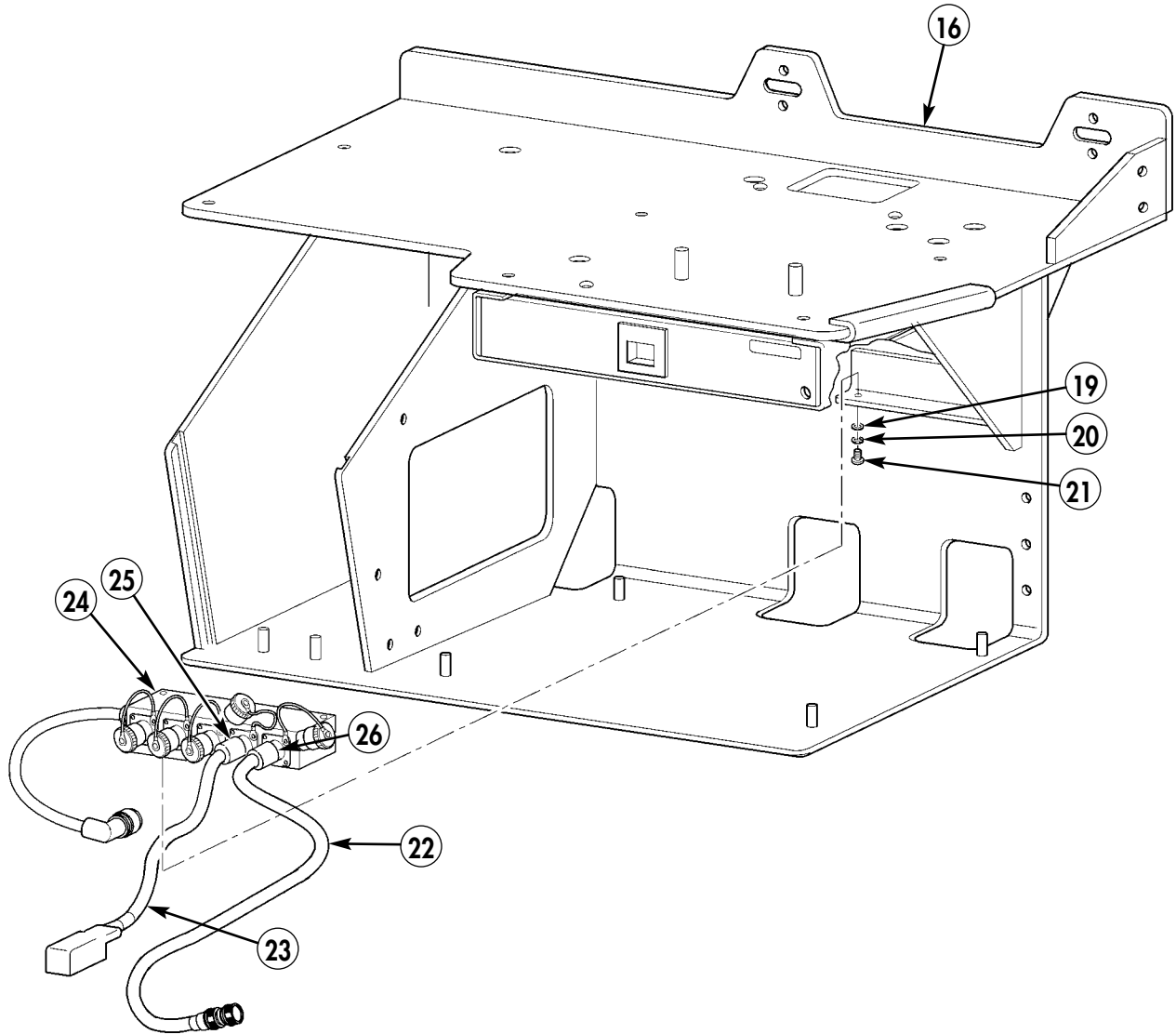

- 19. WASHER – MS27183-47 – QTY. 2
- 20. LOCKWASHER – MS35338-43 – QTY. 2
- 21. SCREW – MS35207-263 – QTY. 2
- 22. W3N CABLE – 881336-1 – QTY. 1
- 23. W3P CABLE – 881335-1 – QTY. 1
- 24. SIAD – 881331-1 – QTY. 1

Figure 5-10.

2-22. Install rack support (30) on tunnel insulation (3) with three capscrews (28), washers (29), spacers (31), three capscrews (27), washers (33), and spacers (32). Do not tighten capscrews (28) and (27) at this time.

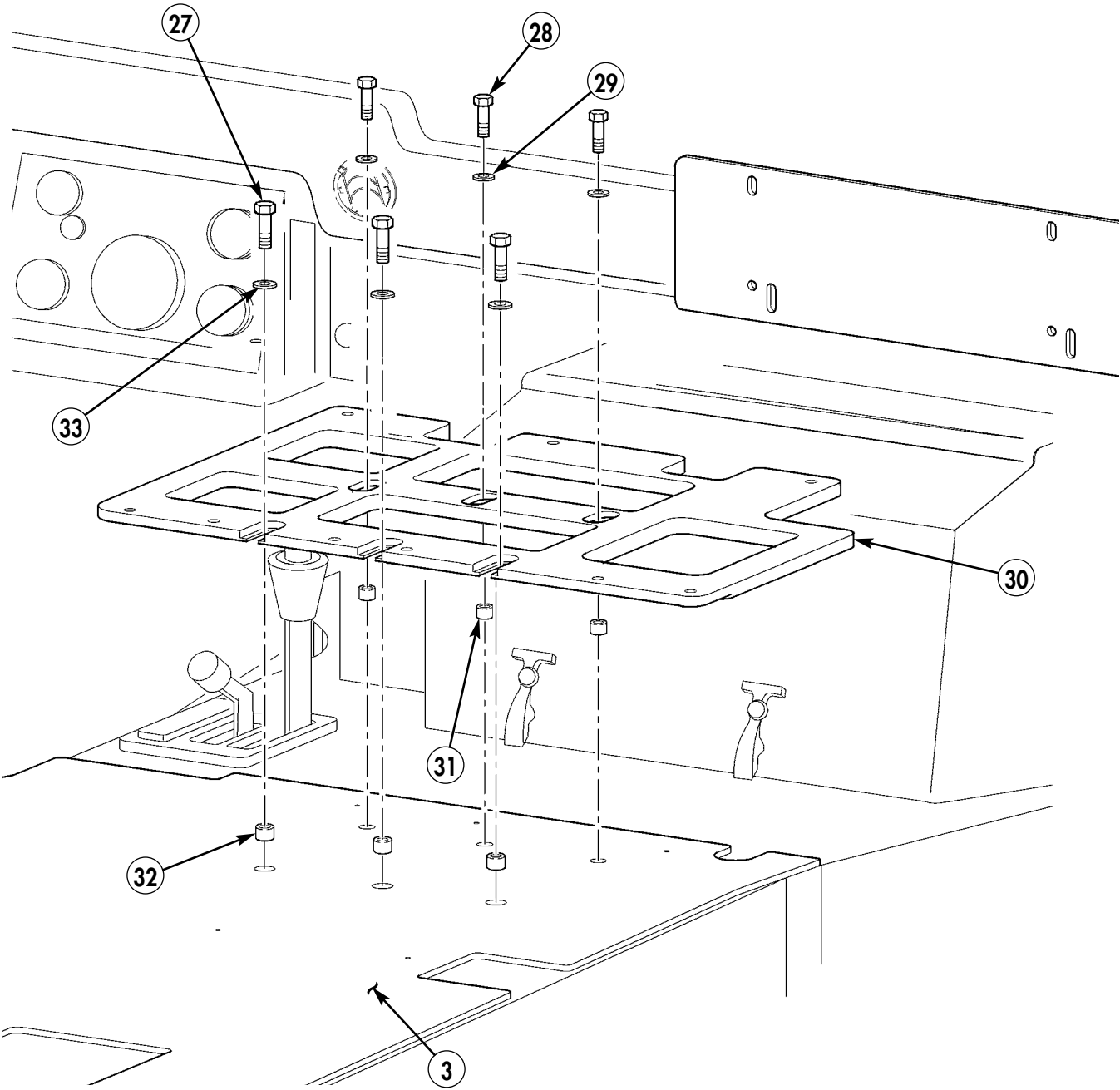

- 27. CAPSCREW - B1821BH038C200N - QTY. 3
- 28. CAPSCREW - B1821BH025C200N - QTY. 3
- 29. WASHER - MS27183-10 - QTY. 3
- 30. RACK SUPPORT - 889509-22 - QTY. 1
- 31. SPACER - 51506-8070R - QTY. 3
- 32. SPACER - 51506-8097R - QTY. 3
- 33. WASHER - MS27183-13 - QTY. 3

Figure 5-11.

- 2-23. Temporarily install integrated rack (16) on rack support (30) with two capscrews (34).
- 2-24. Position rack support (30) and top mounting holes (35) of integrated rack (16) to radio rack support plate (36).
- 2-25. Remove two capscrews (34) and integrated rack (16) from rack support (30).
- 2-26. Tighten rack support (30) to tunnel floor (10) with six capscrews (28) and (27).

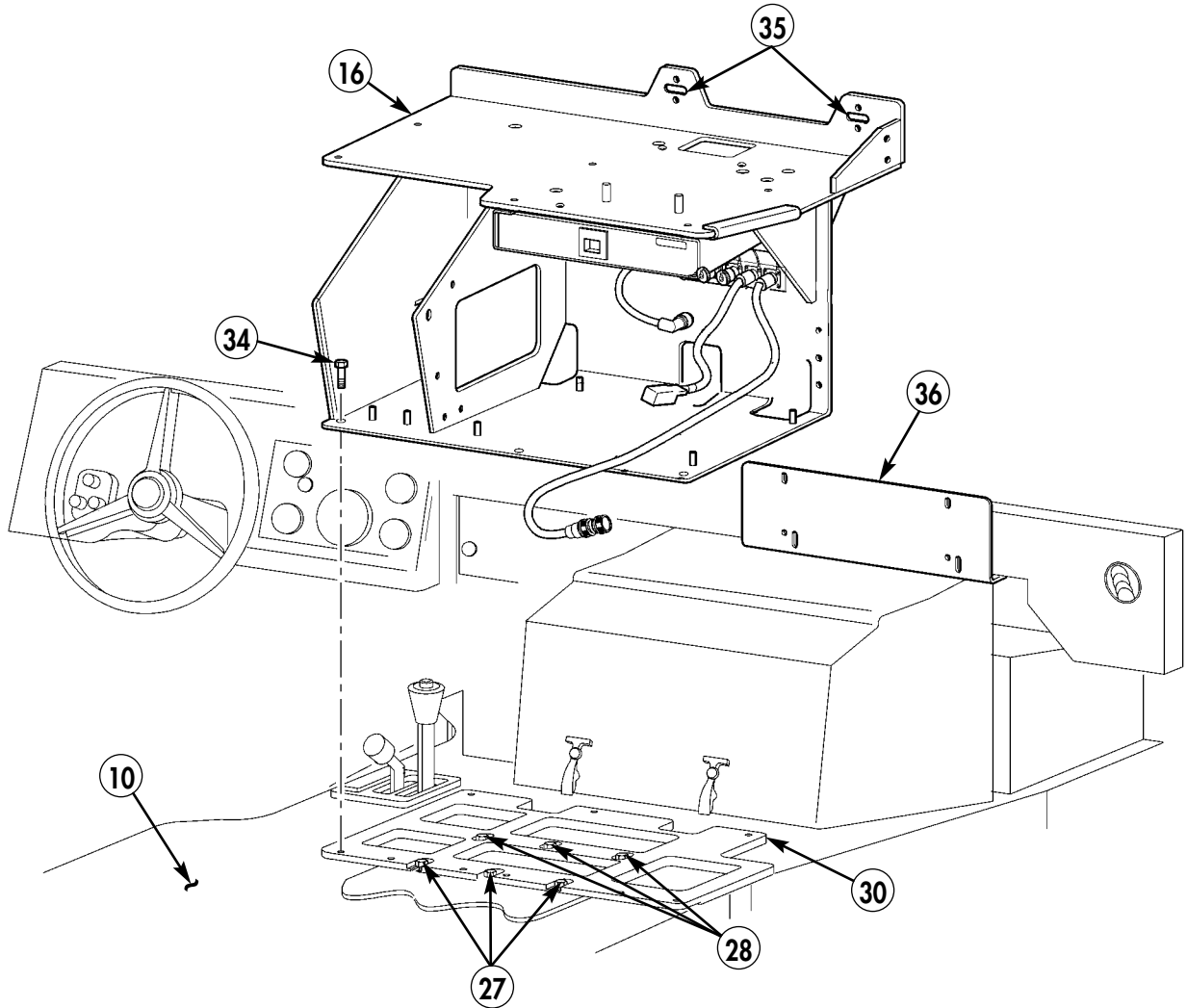

34. CAPSCREW – B1821BH025C088N – QTY. 2

Figure 5-12.

NOTE

SIAD and cables not shown for clarity.

- 2-27.** Install integrated rack (16) on rack support (30) with six capscrews (34), lockwashers (37), and washers (38).

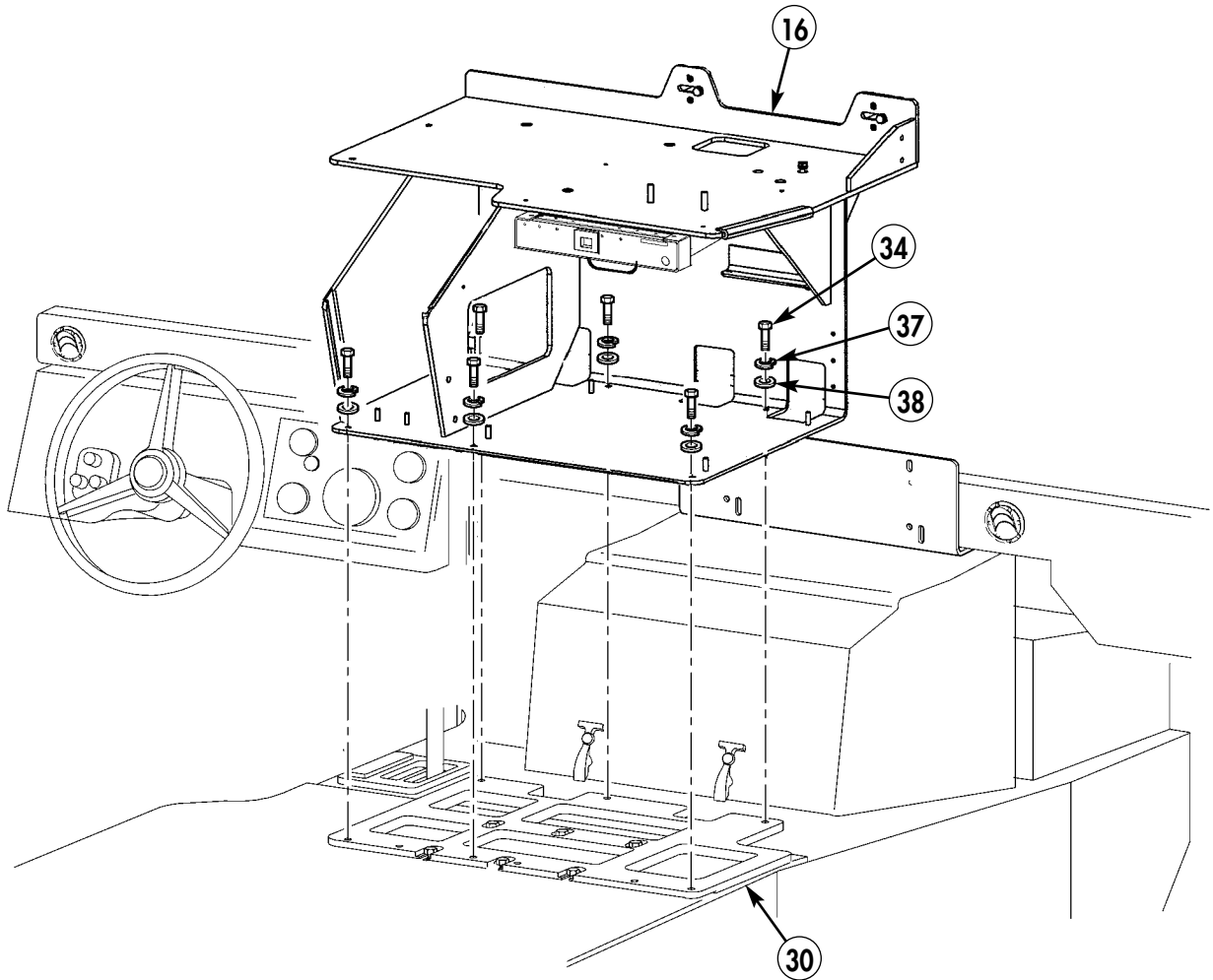

- 34. CAPSCREW – B1821BH025C088N – QTY. 4**
37. LOCKWASHER – MS35338-44 – QTY. 6
38. WASHER – MS27183-10 – QTY. 6

Figure 5-13.

2-28. Fabricate ground strap (42) from 8-in. length of braided wire and two terminal lugs.

NOTE

Remove paint from vicinity of integrated rack mounting holes before performing step 2-29. Apply antiseize compound as required.

2-29. Attach integrated rack (16) to radio rack support plate (36) using two capscrews (39), washers (40), ground strap (42), two washers (40), and nuts (41).

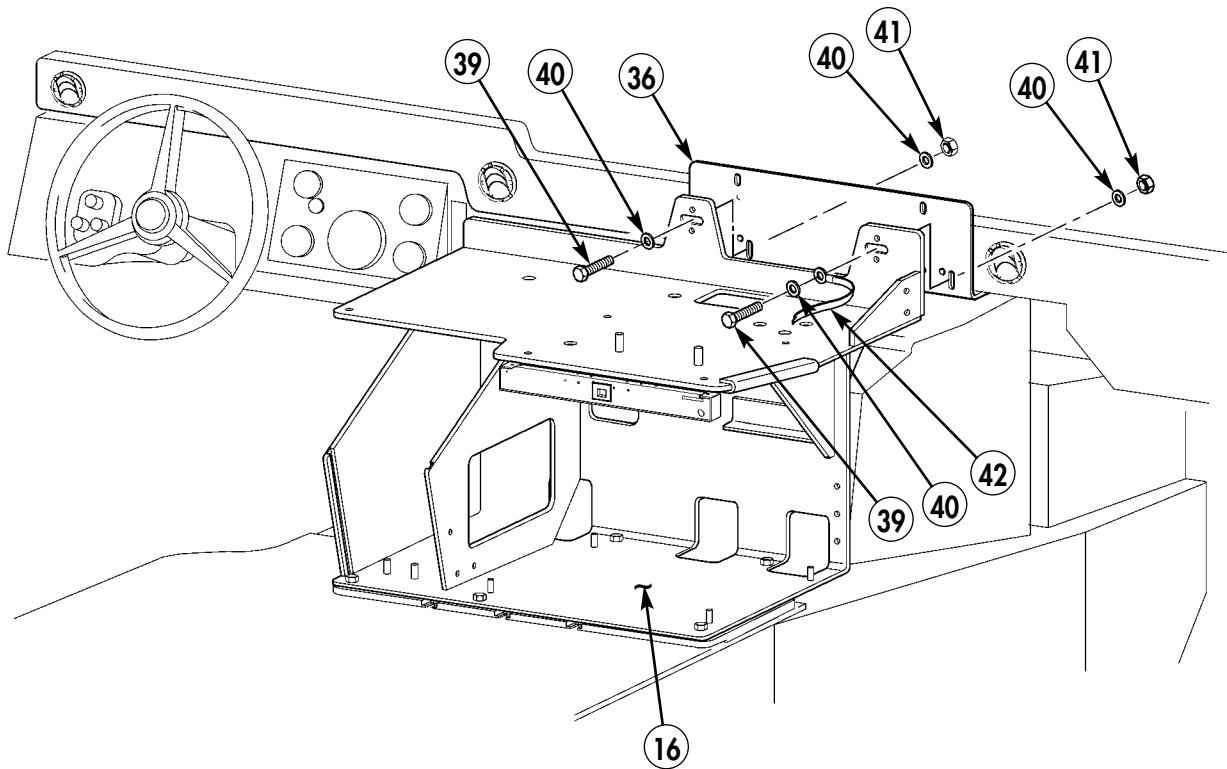

- 39. CAPSCREW – B1821BH025C150N – QTY. 2
- 40. WASHER – 2436161 – QTY. 4
- 41. LOCKNUT – M45913/4-4CG8Z – QTY. 2
- 42. GROUND STRAP
 - BRAIDED WIRE – AA59569F30T0375 – QTY. A/R
 - TERMINAL LUG – MS20659-141 – QTY. 2

Figure 5-14.

**Section III. SINGARS MOUNTING TRAY, AMP GUARD,
AND FBCB2 COMPONENTS INSTALLATION**

CAUTION

Take care when removing antenna power switch cover as antenna switch is still connected. Equipment damage may occur if antenna power switch cover is removed forcefully.

NOTE

Antenna switch box is for Blue Force Tracking (BFT). If not installing BFT, skip to step 3-7.

- 3-1.** Remove four screws (2) and antenna power switch cover (1) from antenna power switch box (3). Retain all hardware.

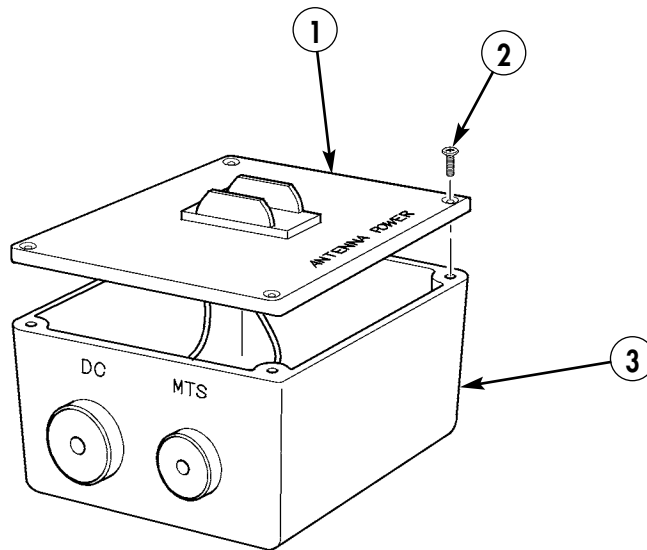

3. SWITCH BOX ASSEMBLY – A1-36044D – QTY. 1

Figure 5-15.

NOTE

- Antenna power switch box mounting holes may already exist in integrated rack. If antenna power switch box mounting holes exist, do not perform step 3-2.
- Antenna power switch box should be flush with cutout in integrated rack and against the rear flange of integrated rack.

- 3-2.** Using antenna power switch box (3) as template, locate and mark two hole positions (5) in integrated rack (4).
- 3-3.** Remove antenna power switch box (3) from integrated rack (4).
- 3-4.** Drill two 0.281-in. diameter holes (5) in integrated rack (4).

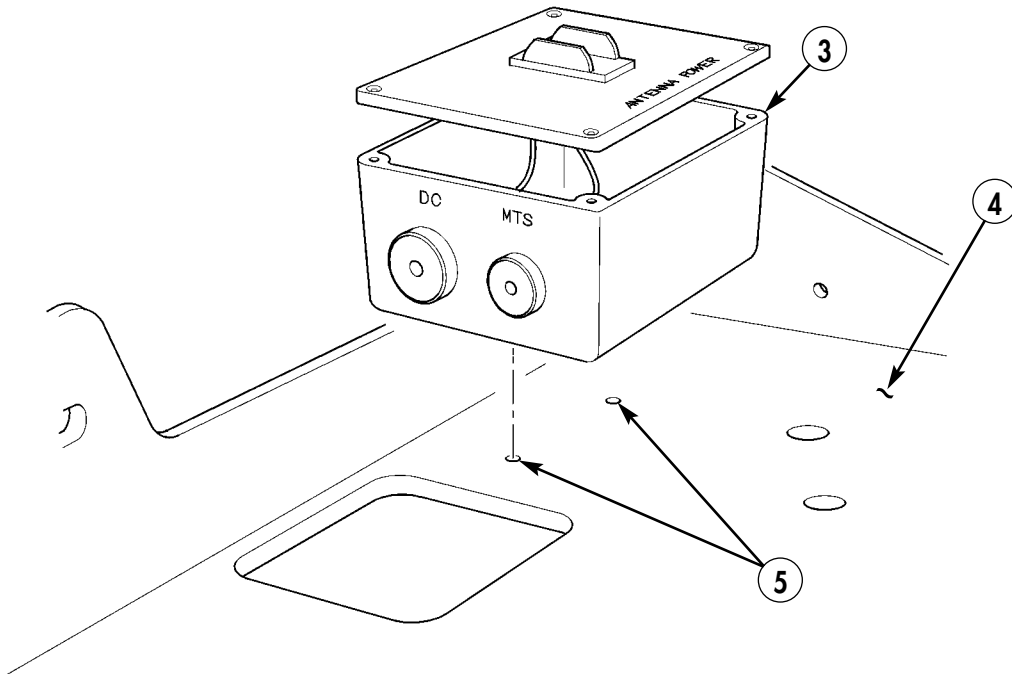
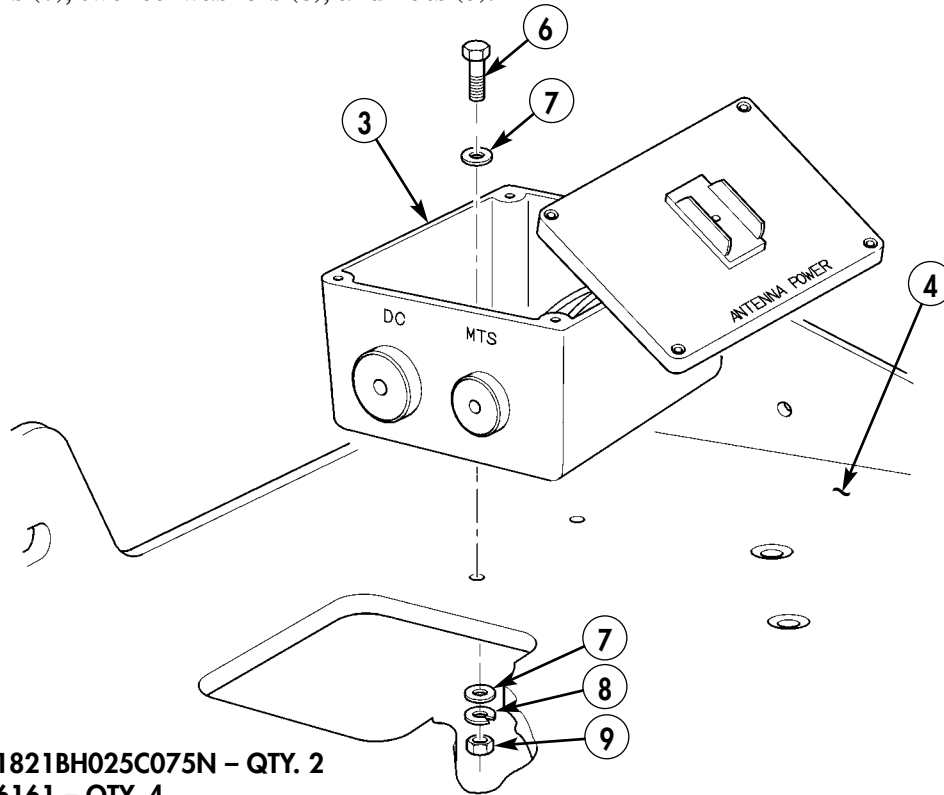

Figure 5-16.

- 3-5. Install antenna power switch box (3) on integrated rack (4) using two capscrews (6), four washers (7), two lockwashers (8), and nuts (9).



6. CAPSCREW - B1821BH025C075N - QTY. 2
 7. WASHER - 2436161 - QTY. 4
 8. LOCKWASHER - MS35338-44 - QTY. 2
 9. NUT - 9419143 - QTY. 2

Figure 5-17.

- 3-6. Install antenna power switch cover (1) on antenna power switch box (3) with four existing screws (2).

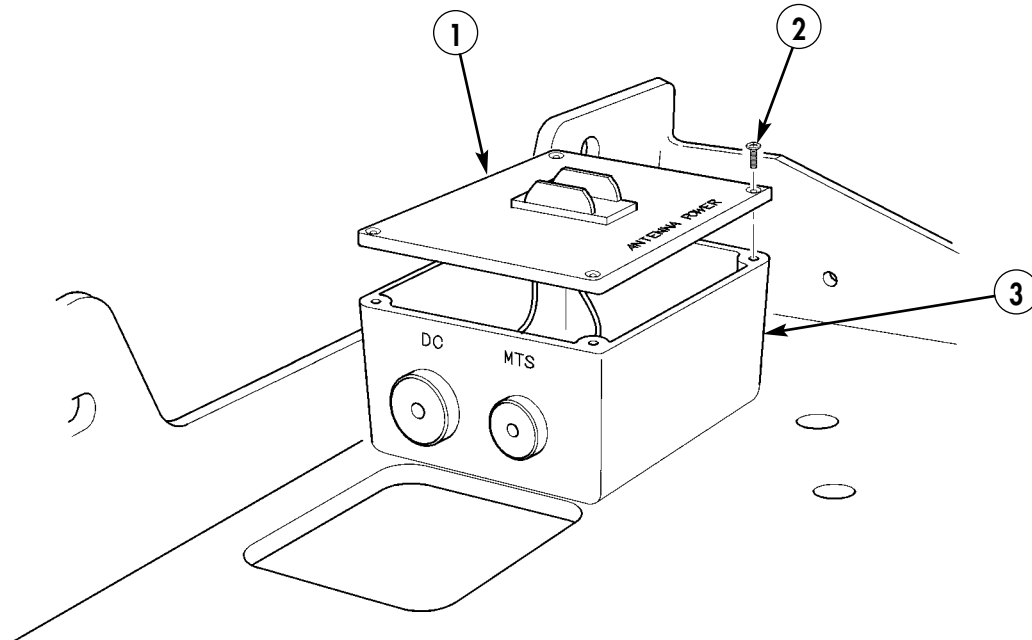
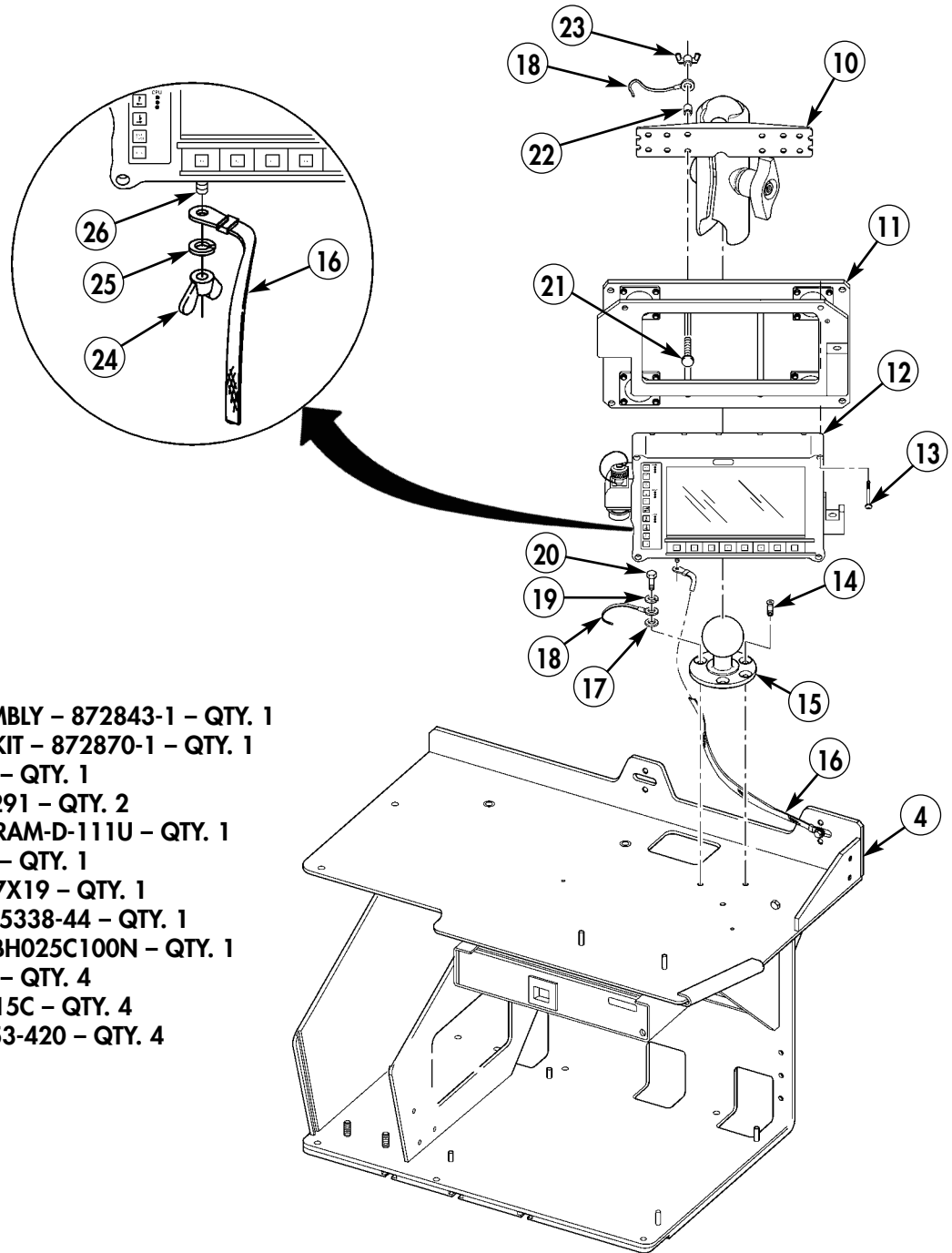

Figure 5-18.

- 3-7. Install ramball mount (15) on integrated rack (4) with two screws (14), lockwasher (19), lanyard (18), and washer (17).
- 3-8. Install display isolation kit (11) on display lock assembly (10) with four bolts (21), spacers (22), lanyard (18), and four wingnuts (23).
- 3-9. Install display unit (12) on display isolation kit (11) with four existing screws (13).
- 3-10. Install display lock assembly (10) on ramball mount (15).
- 3-11. Install ground strap (16) on display ground stud (26) with existing lockwasher (25) and wingnut (24).



- 10. DISPLAY LOCK ASSEMBLY - 872843-1 - QTY. 1
- 11. DISPLAY ISOLATION KIT - 872870-1 - QTY. 1
- 12. DISPLAY - 881293-1 - QTY. 1
- 14. SCREW - MS35190-291 - QTY. 2
- 15. RAMBALL MOUNT - RAM-D-111U - QTY. 1
- 17. WASHER - 2436161 - QTY. 1
- 18. LANYARD - 8925T5-7X19 - QTY. 1
- 19. LOCKWASHER - MS35338-44 - QTY. 1
- 20. CAPSCREW - B1821BH025C100N - QTY. 1
- 21. BOLT - MS35751-18 - QTY. 4
- 22. SPACER - 10705AL315C - QTY. 4
- 23. WINGNUT - MS51553-420 - QTY. 4

Figure 5-19.

- 3-12. Place mounting bracket (33) on two existing studs (27).
- 3-13. Attach rod (30) to left rail weldment (32) and right rail weldment (29) with two screws (28).
- 3-14. Place rail assembly on two right-hand studs (27) on integrated rack (4) and attach left rail weldment (32) to integrated rack (4) with three capscrews (31).

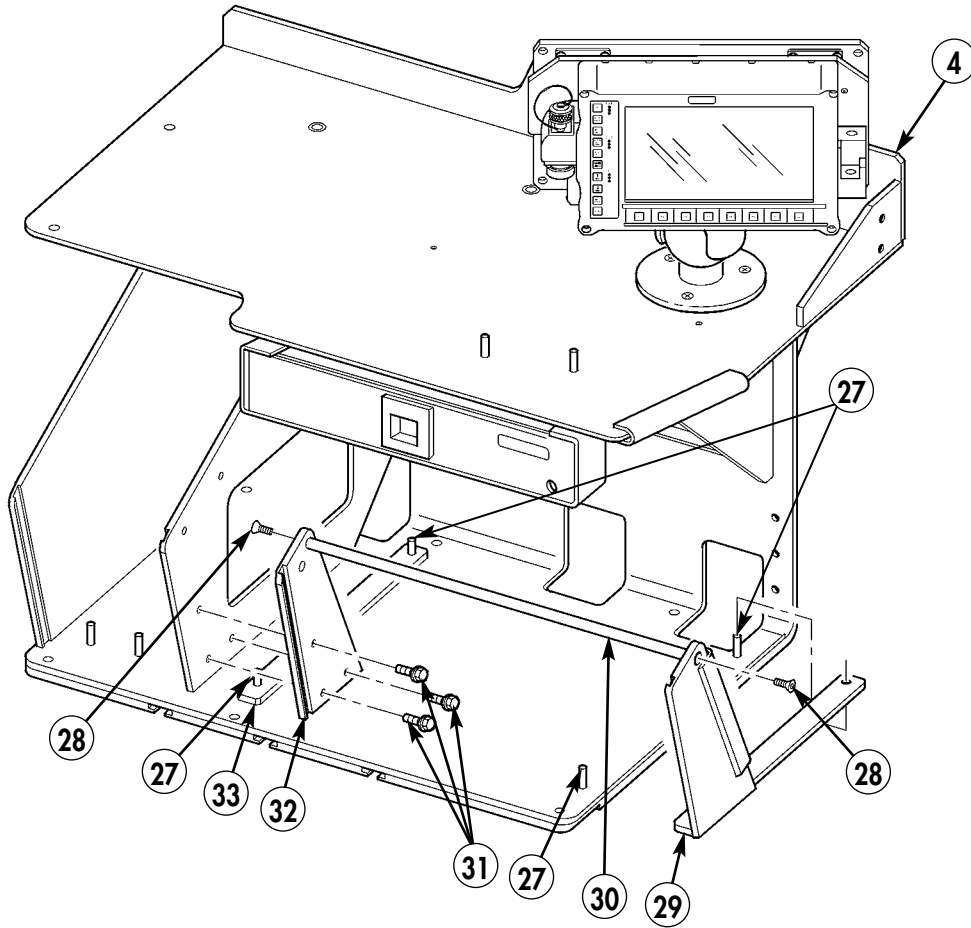

- 28. SCREW – MS35190-287 – QTY. 2
- 29. RIGHT RAIL WELDMENT – 889567-22 – QTY. 1
- 30. ROD – 889567-16 – QTY. 1
- 31. CAPSCREW – B1821BH025C075N – QTY. 3
- 32. LEFT RAIL WELDMENT – 889567-12 – QTY. 1
- 33. MOUNTING BRACKET – 889567-14 – QTY. 1

Figure 5-20.

- 3-15. Install CPU isolation kit (42) on integrated rack (4) and four existing studs (27), with three washers (46), lockwashers (47), and nuts (36).
- 3-16. Position CPU (34) on CPU isolation kit (42).
- 3-17. Install ground strap (38) on stud (35) of CPU (34) with existing wingnut (39), lockwasher (40), and washer (41).
- 3-18. Secure ground strap (38) to stud (27) of integrated rack (4) with lockwasher (37) and nut (36).
- 3-19. Connect P1 connector (52) from Serial Interface Adapter Device (SIAD) (54) to J3 connector (49) on CPU (34).
- 3-20. Connect W1P2 connector of W1 cable (51) to J1 connector (50) on CPU (34). Route W1 cable (51) through access cut out (44) of integrated rack (4) to top of integrated rack (4).
- 3-21. Connect W2P1 connector of W2 cable (53) to J4 connector (48) on CPU (34). Route W2 cable through access cut out (44) of integrated rack (4) towards FBCB2 display unit (43). Connect in step 3-33.
- 3-22. Route W3N cable (55) from SIAD (54) through access cut out (44) of integrated rack (4). Connect to Vehicular Amplifier Adapter (VAA) in step 3-40.
- 3-23. Secure CPU (34) to CPU isolation kit (42) with two locking devices (45).

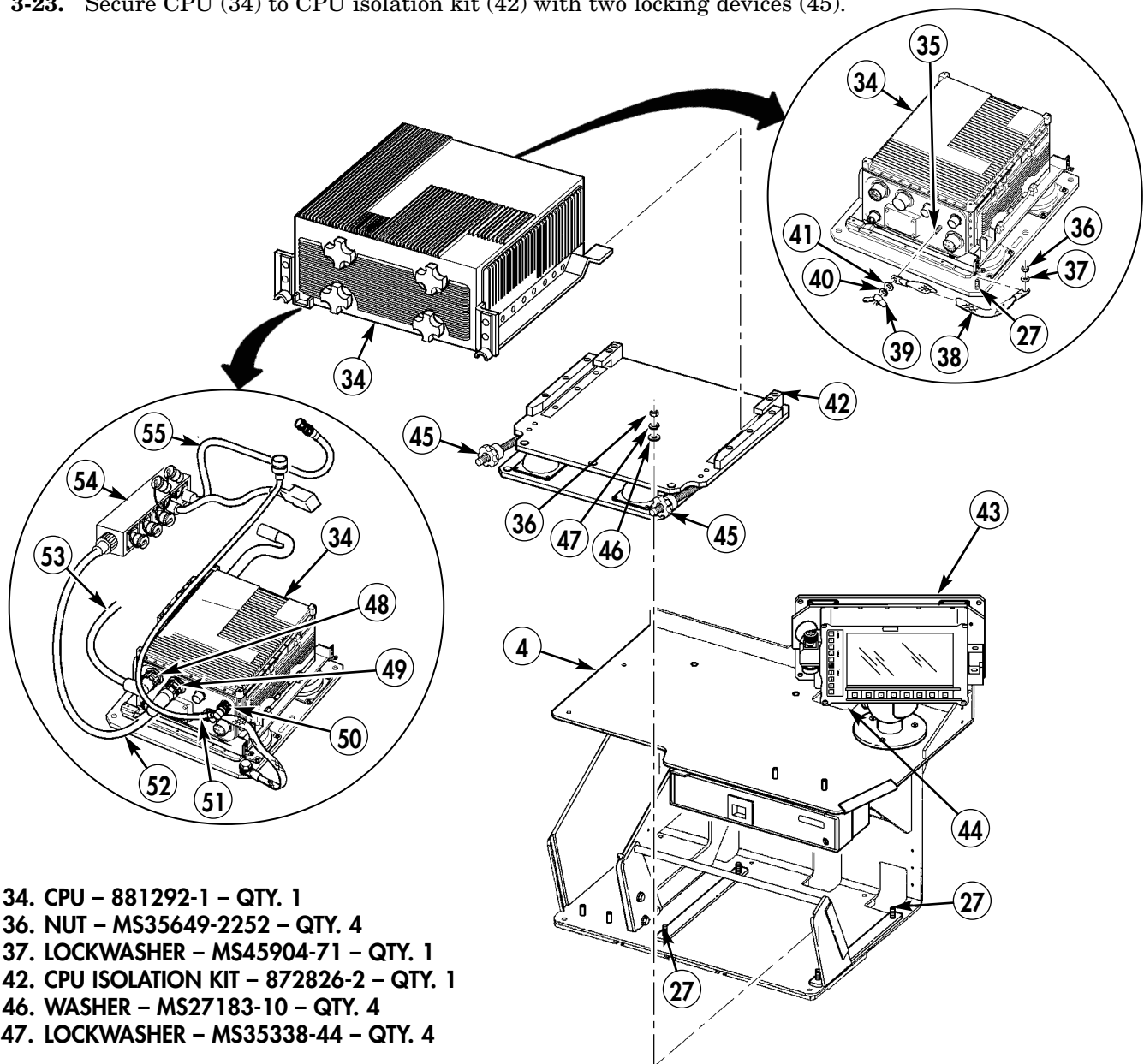

- 34. CPU – 881292-1 – QTY. 1
- 36. NUT – MS35649-2252 – QTY. 4
- 37. LOCKWASHER – MS45904-71 – QTY. 1
- 42. CPU ISOLATION KIT – 872826-2 – QTY. 1
- 46. WASHER – MS27183-10 – QTY. 4
- 47. LOCKWASHER – MS35338-44 – QTY. 4

Figure 5-21.

- 3-24. Remove paint from four mounting holes (61) on integrated rack (4). Apply antiseize compound as required.
- 3-25. Remove paint from four mounting holes (60) on MT-6352/VRC mounting base (59). Apply antiseize compound as required.

NOTE

Two lockwashers and nuts are used on driver's side screws only.

- 3-26. Mount MT-6352/VRC mounting base (59) and amp guard (63) on integrated rack (4) with two screws (56), four lockwashers (57), and two nuts (62). Secure mount MT-6352/VRC mounting base (59) on integrated rack (4) with two capscrews (58) and lockwashers (57).
- 3-27. Place warning decal (64) on amp guard (63).

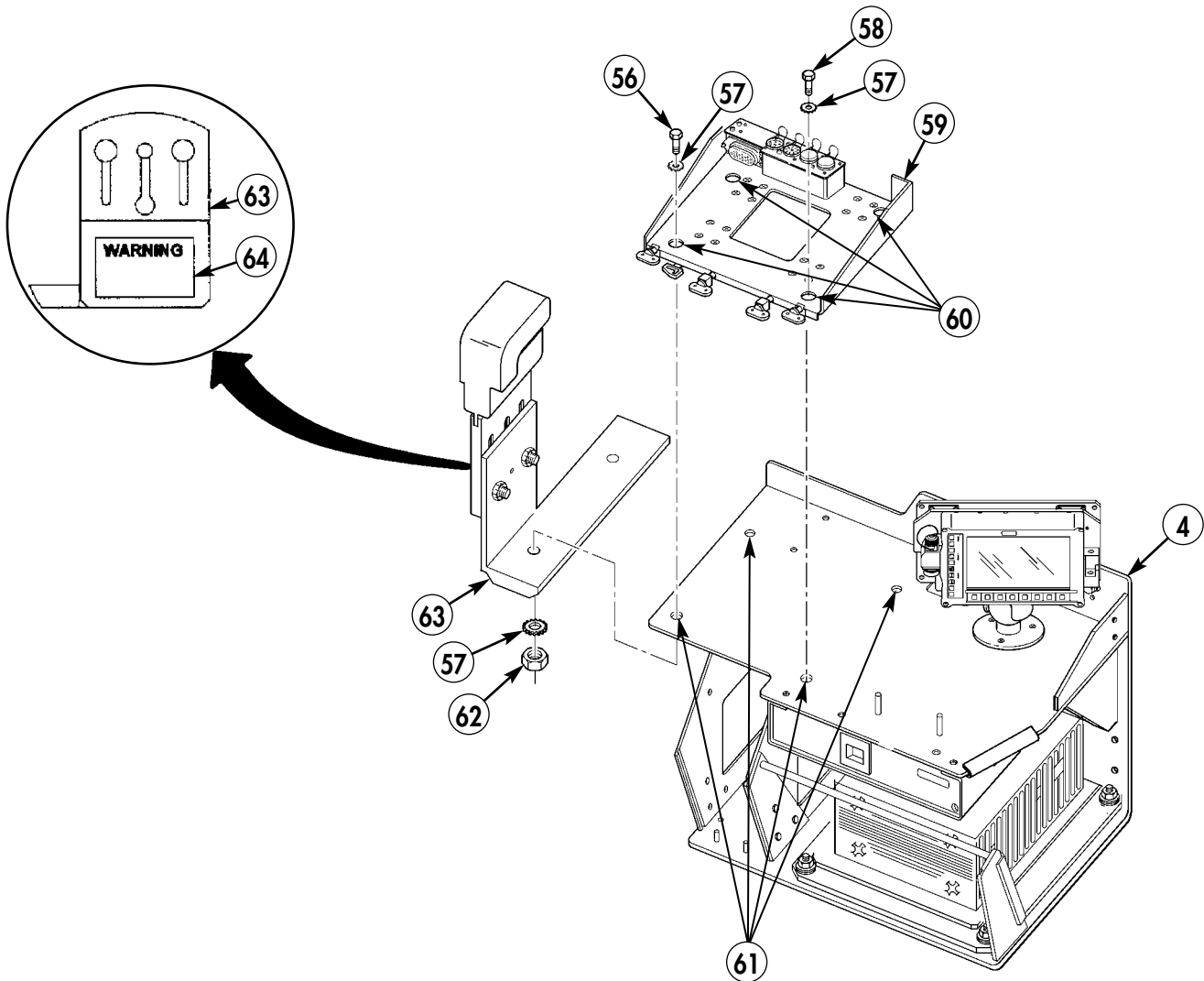

- 56. CAPSCREW – B1821BH031F125N – QTY. 2
- 57. LOCKWASHER – MS45904-72 – QTY. 6
- 58. CAPSCREW – B1821BH031F100N – QTY. 2
- 59. MOUNTING BASE, MT-6352/VRC – A3013367-1 – QTY. 1
- 62. NUT – 9418892 – QTY. 2
- 63. AMP GUARD – 872842-1 – QTY. 1
- 64. DECAL – 861868-2 – QTY. 1

Figure 5-22.

- 3-28. Insert kickplate (67) into grooves of integrated rack (4).
- 3-29. Install Master Control Station (MCS) (69) on mounting surface of kickplate (67) using two existing studs (68), washers (66), lockwashers (65), and nuts (62).

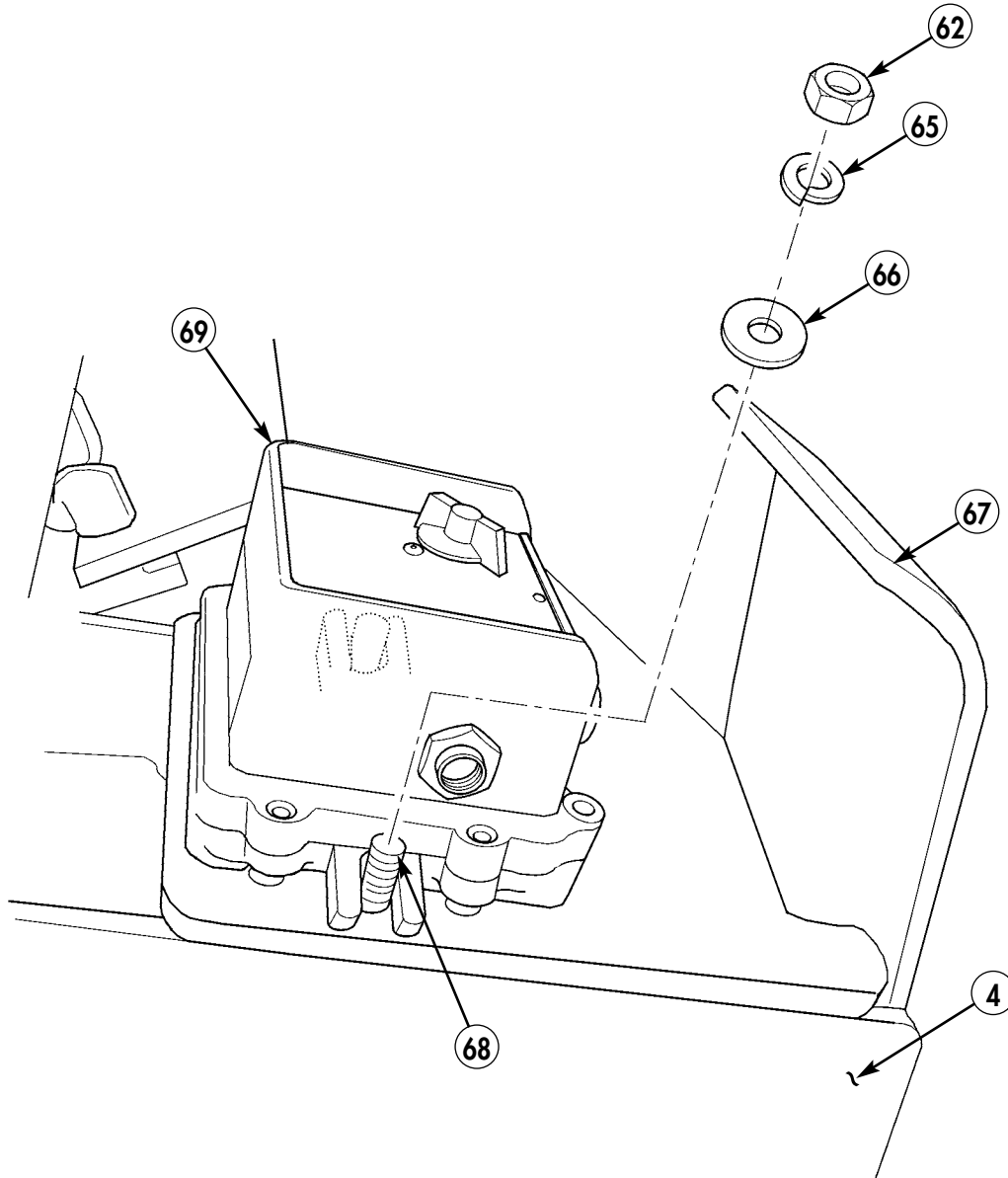

- 62. NUT - 120376 - QTY. 2
- 65. LOCKWASHER - MS35338-45 - QTY. 2
- 66. WASHER - 10910174-19 - QTY. 2
- 69. MCS - A3206623 - QTY. 1

Figure 5-23.

- 3-30. Insert kickplate (72) into grooves of right rail weldment (29) and left rail weldment (32).
- 3-31. Insert quick-release pin (71) through hole (70) in kickplate (72), left rail weldment (32), and integrated rack (4).

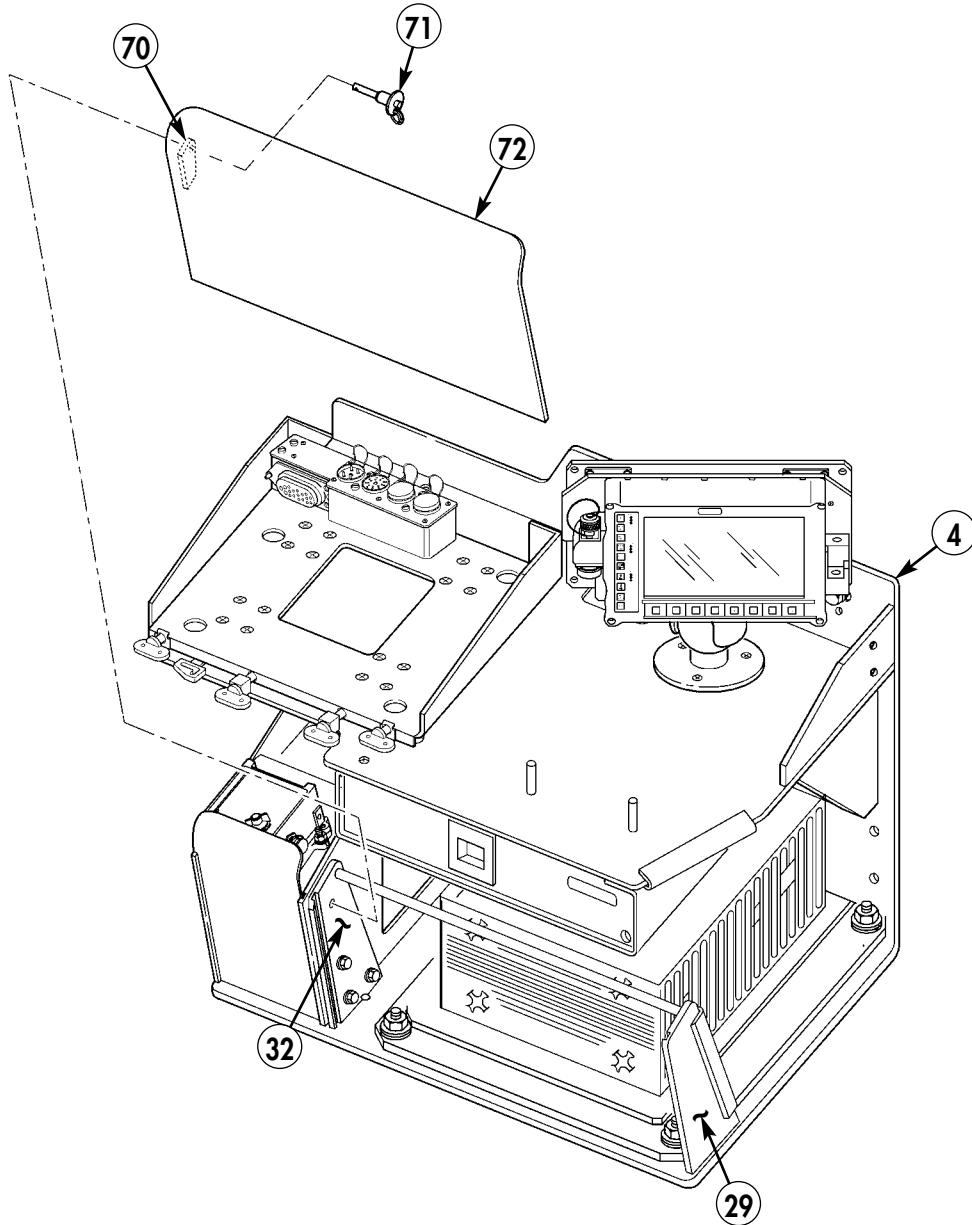

72. FOOTREST WELDMENT – 889567-21 – QTY. 1

Figure 5-24.

- 3-32.** Install Full Function Control Station (FFCS) (74) on integrated rack (4) using two existing studs (73), washers (66), lockwashers (65), and nuts (62).

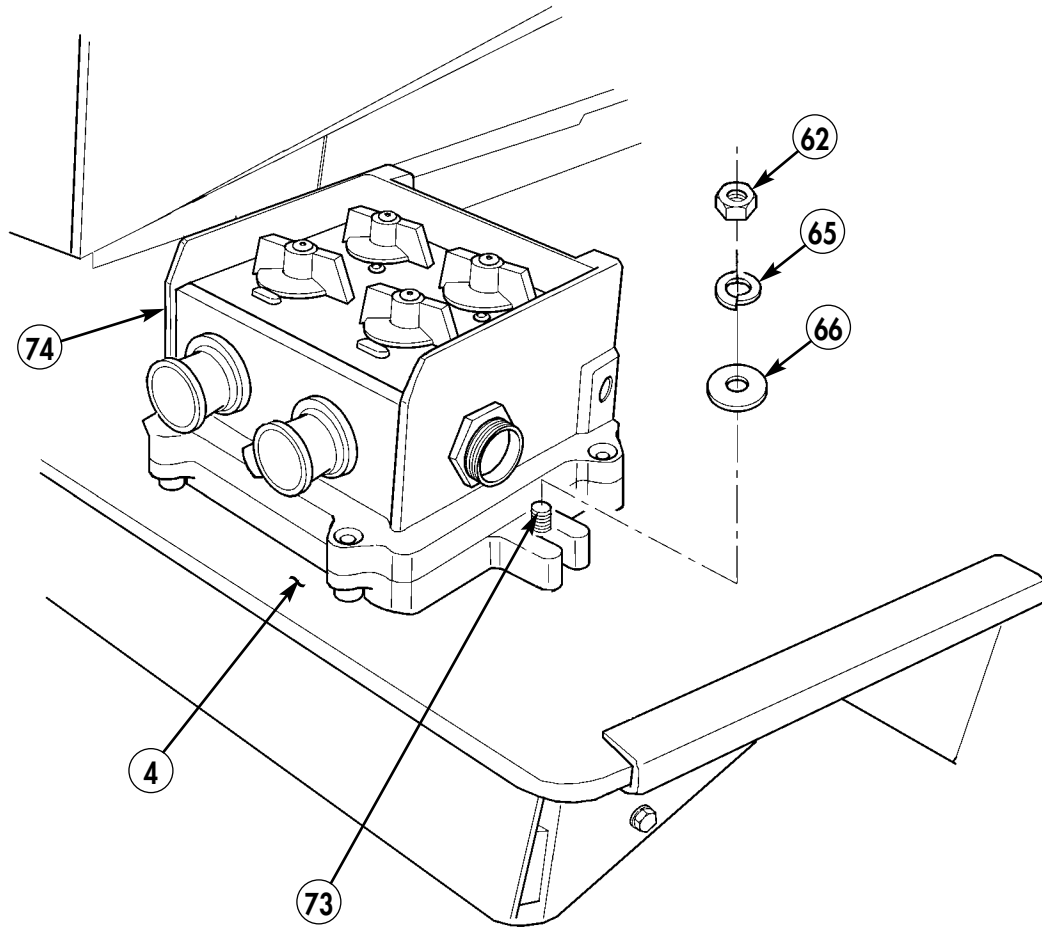

62. NUT - 120376 - QTY. 2
65. LOCKWASHER - MS35338-45 - QTY. 2
66. WASHER - 10910174-19 - QTY. 2
74. FULL FUNCTION CONTROL STATION - A3206624 - QTY. 1

Figure 5-25.

- 3-33. Connect W2P2 connector of W2 cable (53) to J1 connector (78) on FBCB2 display unit (43).
- 3-34. Connect W1P1 connector of W1 cable (51) to A4J2 connector (80) on MT-6352/VRC mounting base (59).
- 3-35. Install keyboard (77) in keyboard stowage box (76).
- 3-36. Connect keyboard cable (79) from keyboard (77) to J2 connector (75) on FBCB2 display unit (43).

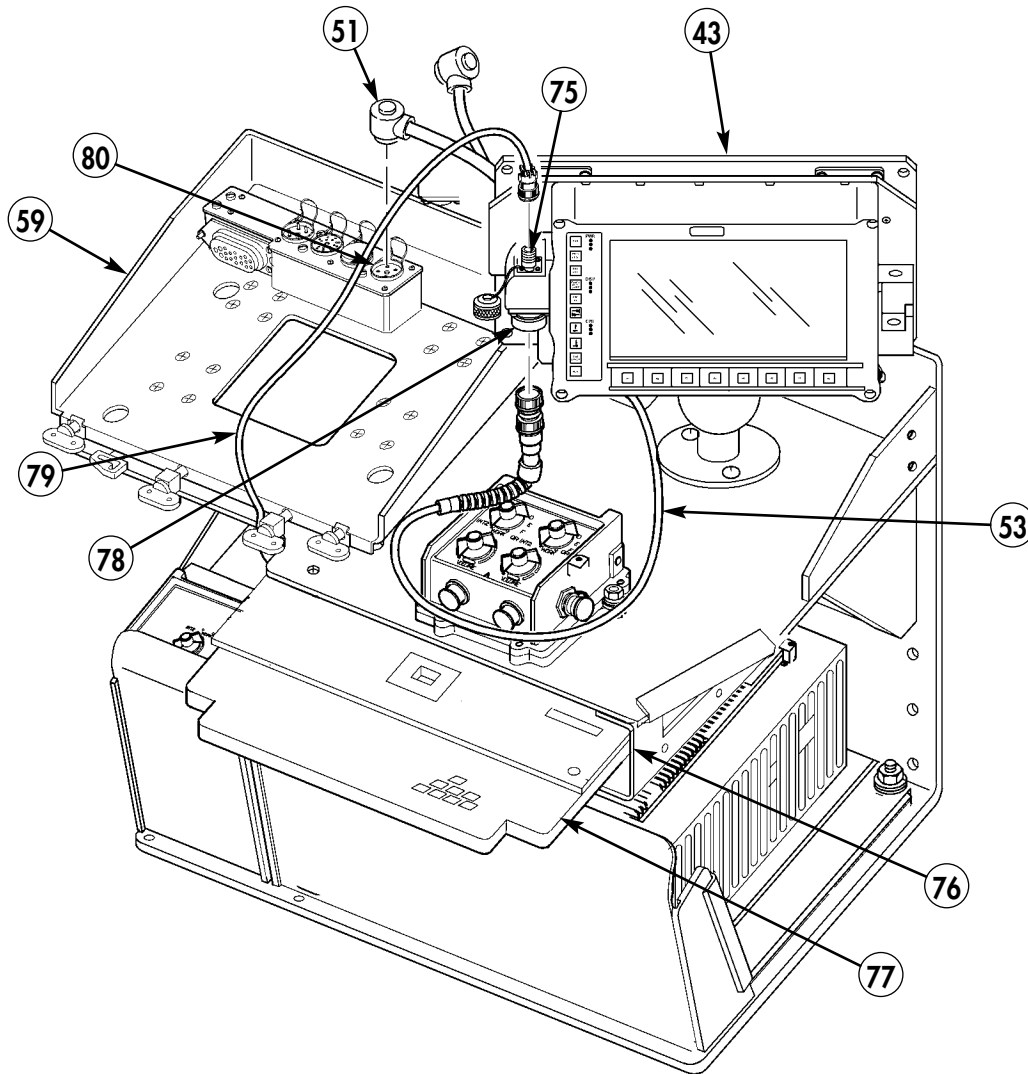

77. KEYBOARD - 501395-1 - QTY. 1

Figure 5-26.

- 3-37. Install Vehicular Amplifier Adapter (VAA) AM-7239 (81) into SINCGARS mount (59).
- 3-38. Lock VAA (81) into position with locking bar (83).
- 3-39. Secure VAA (81) to SINCGARS mount (59) with two outer locking devices (82).

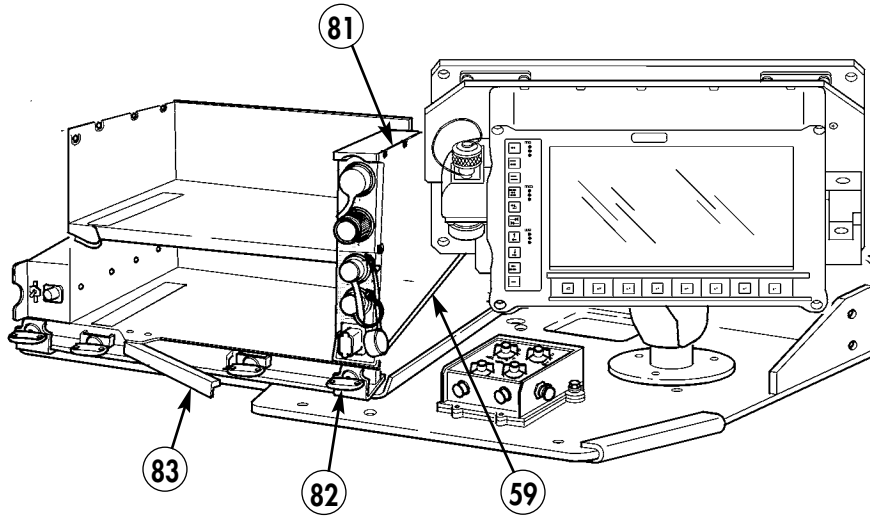

Figure 5-27.

- 3-40. Connect W3N cable (55) to J3 connector (84) on VAA (81).

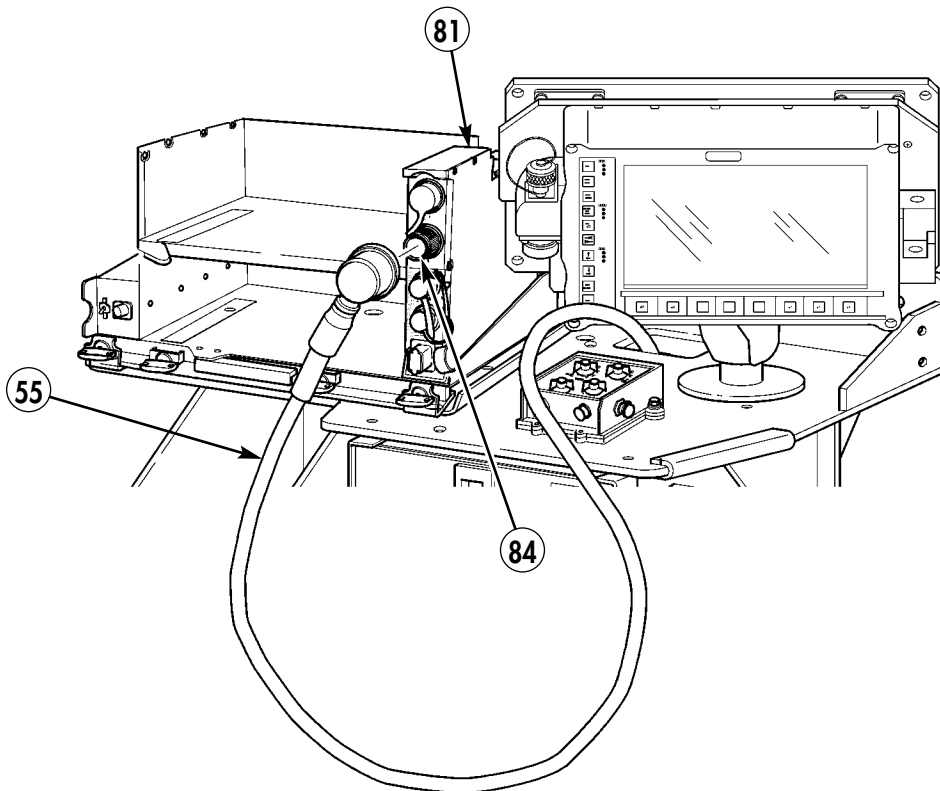

Figure 5-28.

Section IV. DAGR INSTALLATION

- 4-1. Remove weather cap. (Refer to TM 9-2320-387-24.)
- 4-2. Remove locknut (5), two washers (6), and capscrew (11) from air intake stack support bracket (1) and mounting bracket (7). Discard locknut (5).
- 4-3. Loosen clamp (13) and remove air intake stack (12) from rubber boot (14) and mounting bracket (7).
- 4-4. Remove two capscrews (2) and (8), lockwashers (3) and (9), and washers (4) and (10) from mounting bracket (7). Remove mounting bracket (7) from vehicle (15). Discard lockwashers (3) and (9).

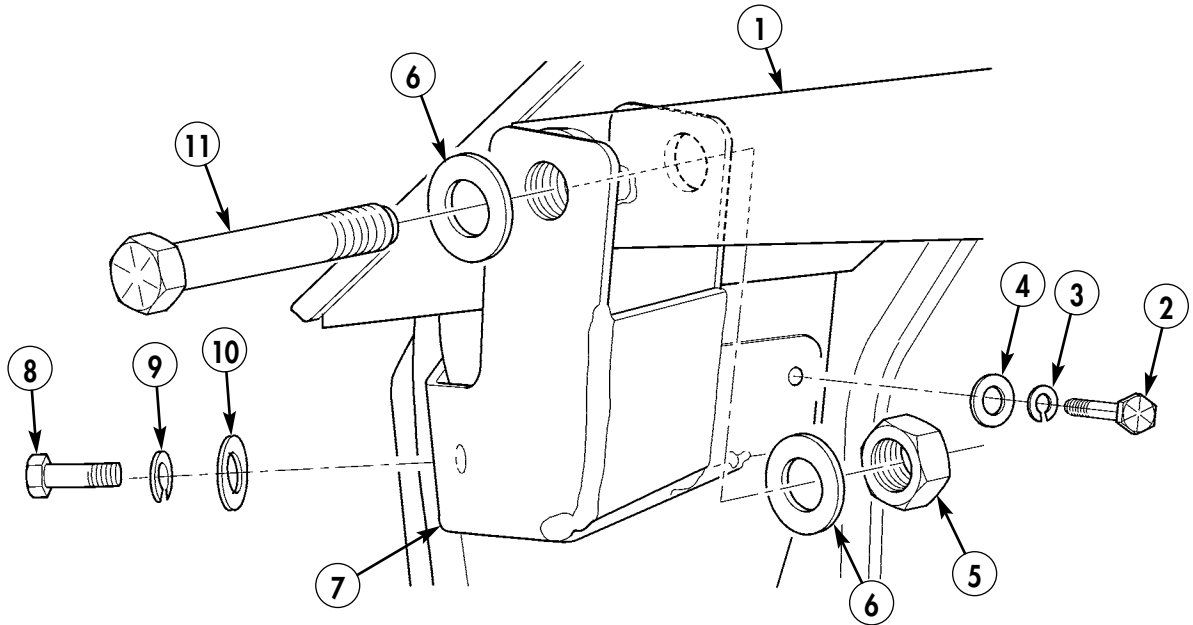

Figure 5-29.

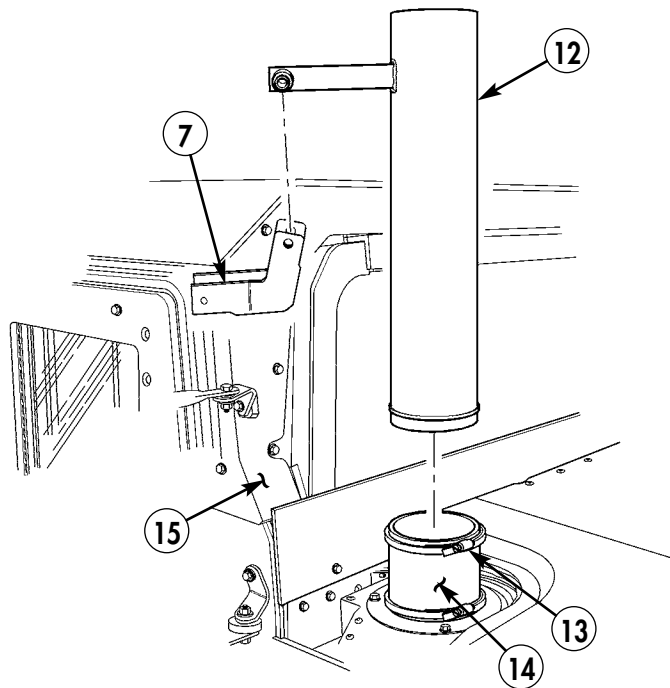

Figure 5-30.

- 4-5. Remove right side windshield wiper. (Refer to TM 9-2320-387-24.)
- 4-6. Remove four screws (19), lockwashers (18), washers (17), and right side front roof armor (16) from vehicle (15). Discard lockwashers (18).

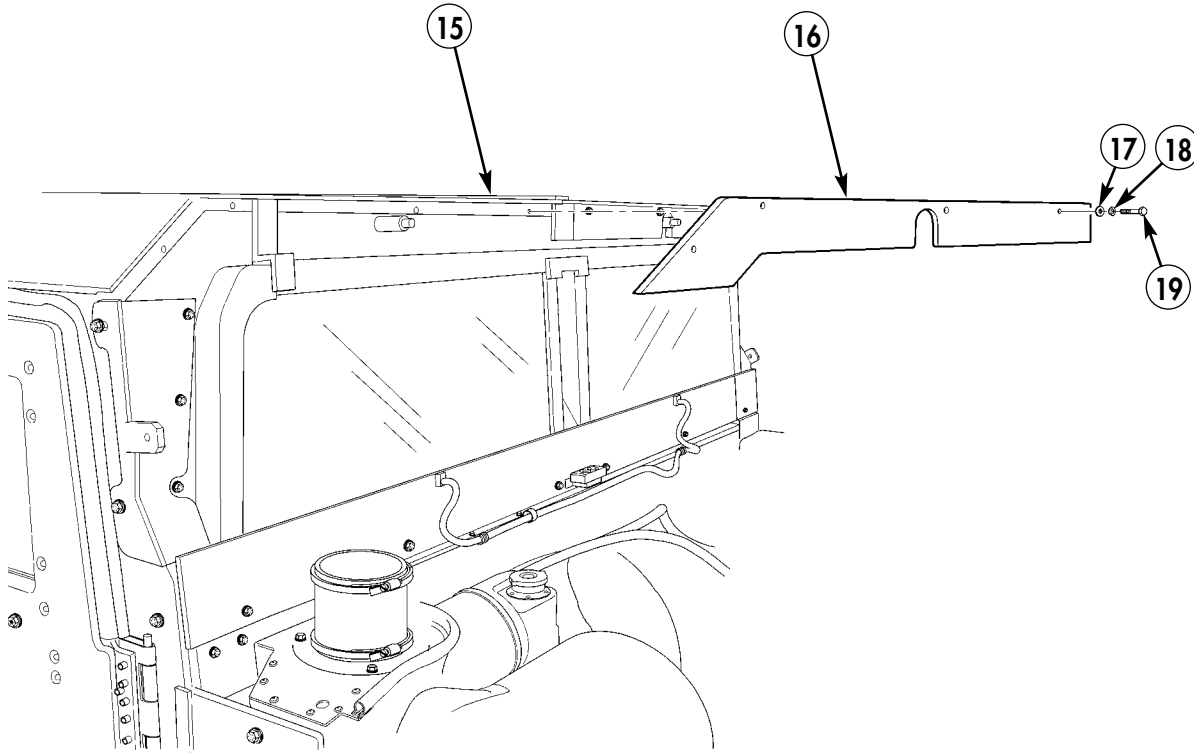

Figure 5-31.

4-7. Install grommet material (20) on armor plate (22).

NOTE

- Leave enough slack to connect cable to DAGR antenna.
- If installing BFT, install BFT cable with DAGR antenna cable at this time. See figure 5-45.

4-8. Route DAGR antenna cable (21) through gap in armor plate (22) to inside of vehicle.

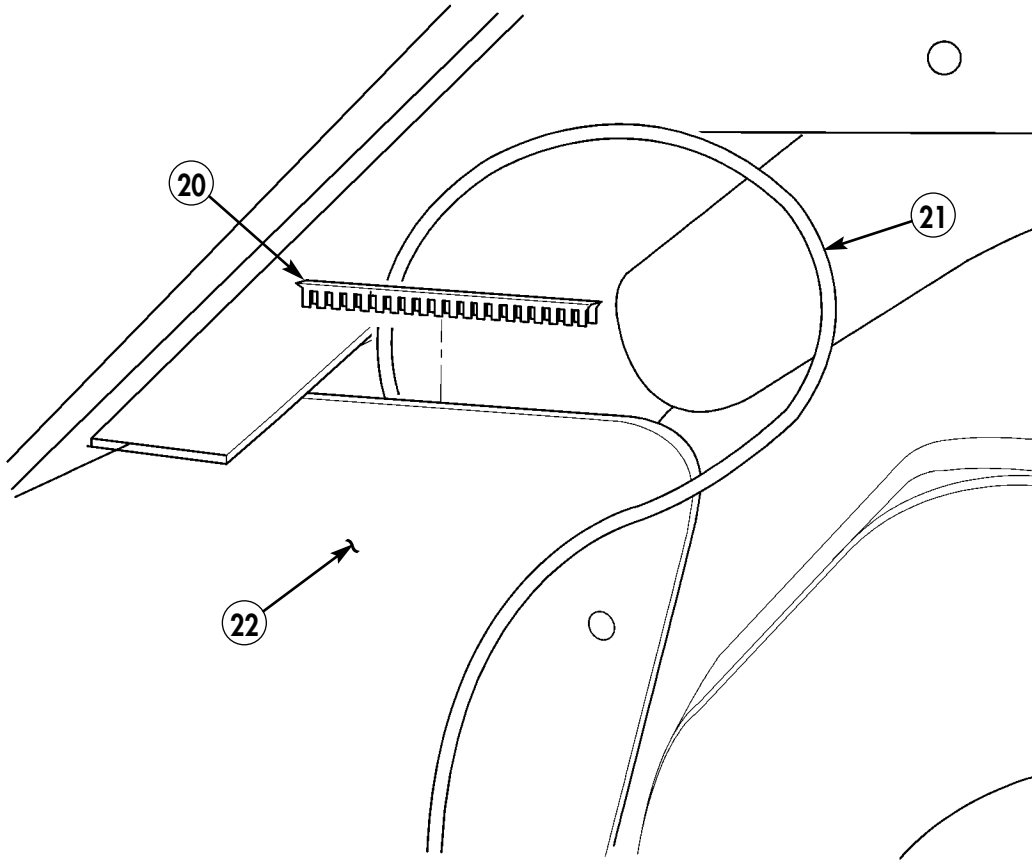

- 20. GROMMET MATERIAL – MS21266-6N – QTY. 3 IN.
- 21A. DAGR ANTENNA CABLE – 987-5016-001 – QTY. 1
- 21B. DAGR ANTENNA CABLE – 987-4640-001 – QTY. 1

Figure 5-32.

- 4-9. Install grommet material (25) on right side roof armor (16).
- 4-10. Install right side front roof armor (16) on vehicle (15) with three existing screws (23), lockwashers (18), and existing washers (17).
- 4-11. Secure right side front roof armor (16) to vehicle with existing screw (19), loop clamp (24), DAGR antenna cable (21), lockwasher (18), and existing washer (17).

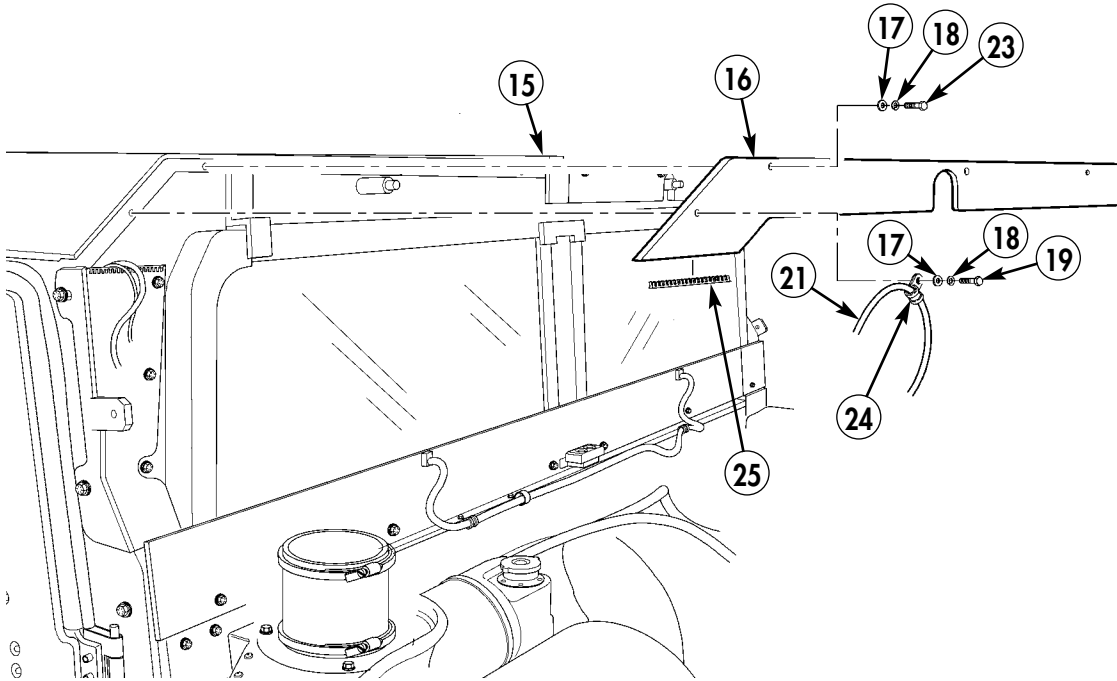

- 18. LOCKWASHER – MS35338-44 – QTY. 4
- 24. CLAMP, LOOP – MS21333-97 – QTY. 1
- 25. GROMMET MATERIAL – MS21266-5N – QTY. 3 IN.

Figure 5-33.

- 4-12. Locate, mark and drill one 0.125-in. diameter pilot hole (29) in air intake stack support bracket (28).
- 4-13. Using support bracket (30) as template, drill 0.125-in. diameter pilot hole (29) in air intake stack support bracket (28).
- 4-14. Enlarge drilled holes (29) in air intake stack support bracket (28) to 0.297-in. diameter.
- 4-15. Install two inserts (27) in air intake stack support bracket (28).
- 4-16. Install antenna (26) on support bracket (30) with lockwasher (32) and screw (33).
- 4-17. Install support bracket (30) and antenna (26) on air intake stack support bracket (28) with two screws (31) and lockwashers (32).

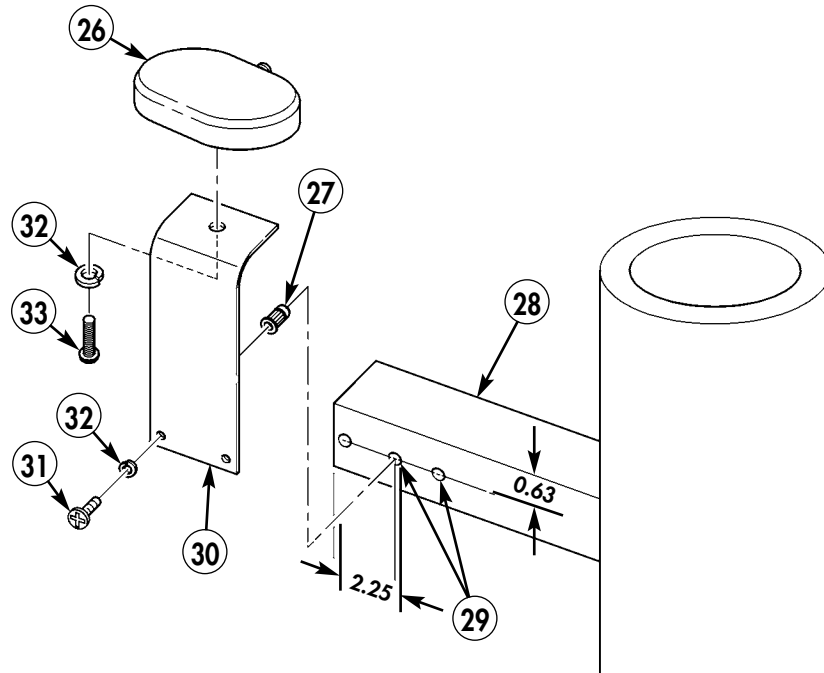

- 26. ANTENNA - 013-1981-010 - QTY. 1
- 27. INSERT - 12446871-3 - QTY. 2
- 30. SUPPORT - 12506676 - QTY. 1
- 31. SCREW - MS35206-267 - QTY. 2
- 32. LOCKWASHER - MS35338-43 - QTY. 3
- 33. SCREW - MS35207-261 - QTY. 1

Figure 5-34.

- 4-18. Install mounting bracket (7) on vehicle (15) with capscrew (2), lockwasher (3), and washer (4).
- 4-19. Secure mounting bracket (7) to vehicle (15) with capscrew (8), lockwasher (9), and washer (10).
- 4-20. Install air intake stack (12) on rubber boot (14).
- 4-21. Secure air intake stack support bracket (1) to mounting bracket (7) with capscrew (11), two washers (6), and locknut (5).
- 4-22. Tighten clamp (13).
- 4-23. Install right side windshield wiper. (Refer to TM 9-2320-387-24.)

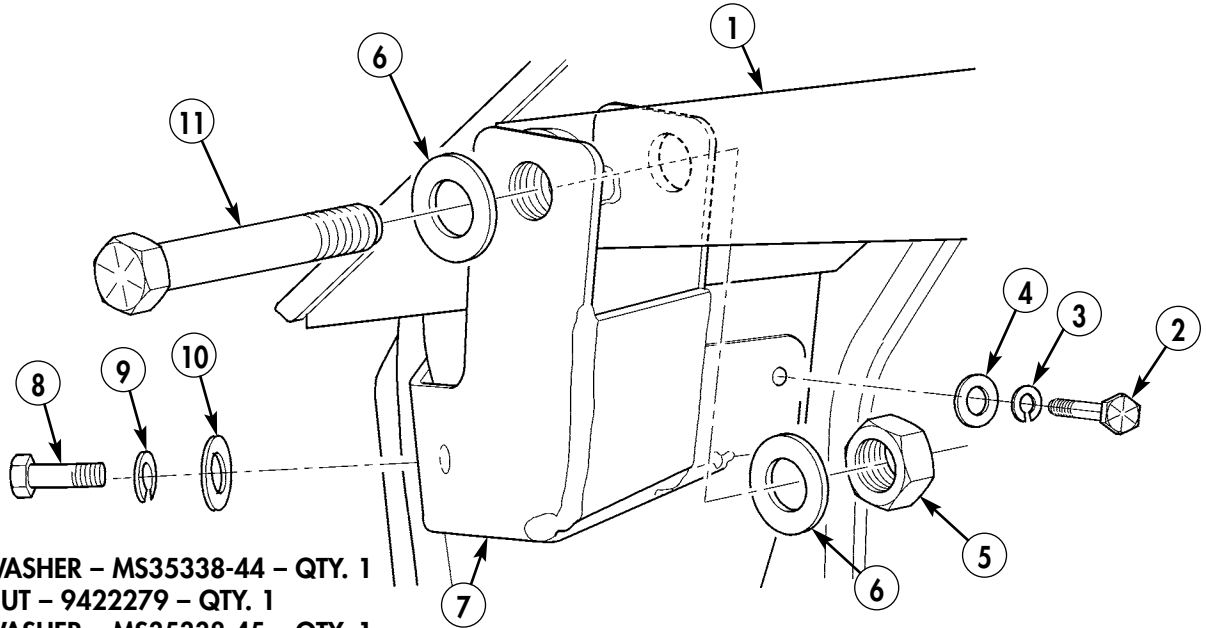

- 3. LOCKWASHER - MS35338-44 - QTY. 1
- 5. LOCKNUT - 9422279 - QTY. 1
- 9. LOCKWASHER - MS35338-45 - QTY. 1

Figure 5-35.

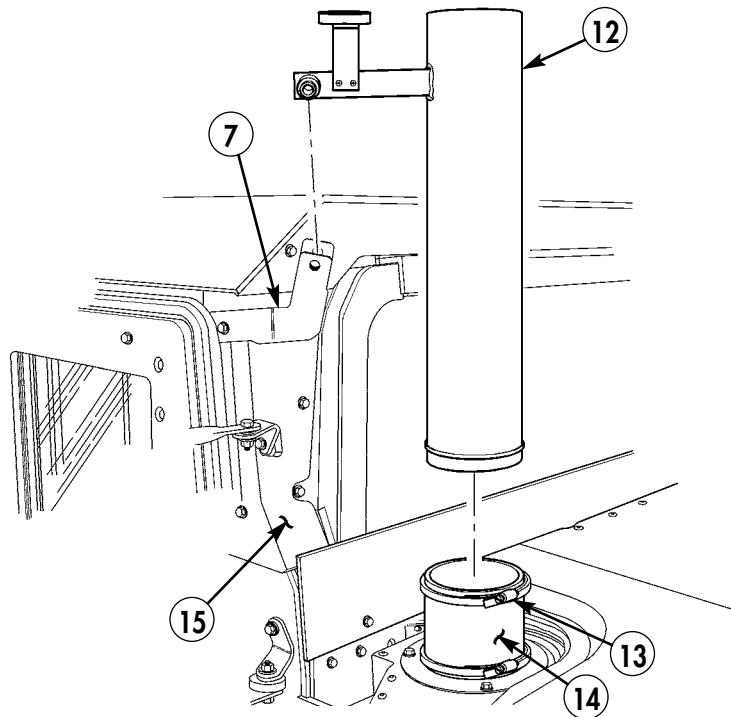

Figure 5-36.

4-24. Install weather cap. (Refer to TM 9-2320-387-24.)

4-25. Connect connector (34) of DAGR antenna cable (21) to DAGR antenna (26).

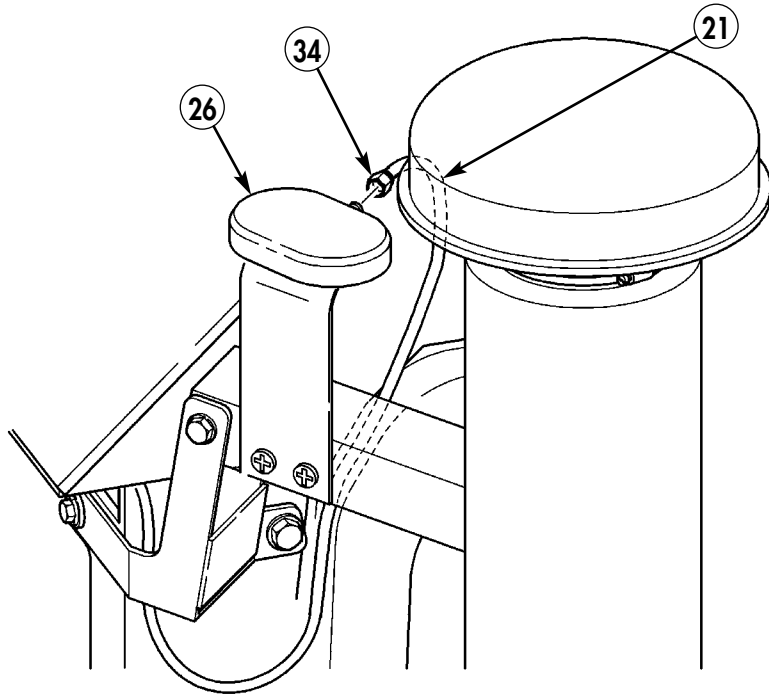
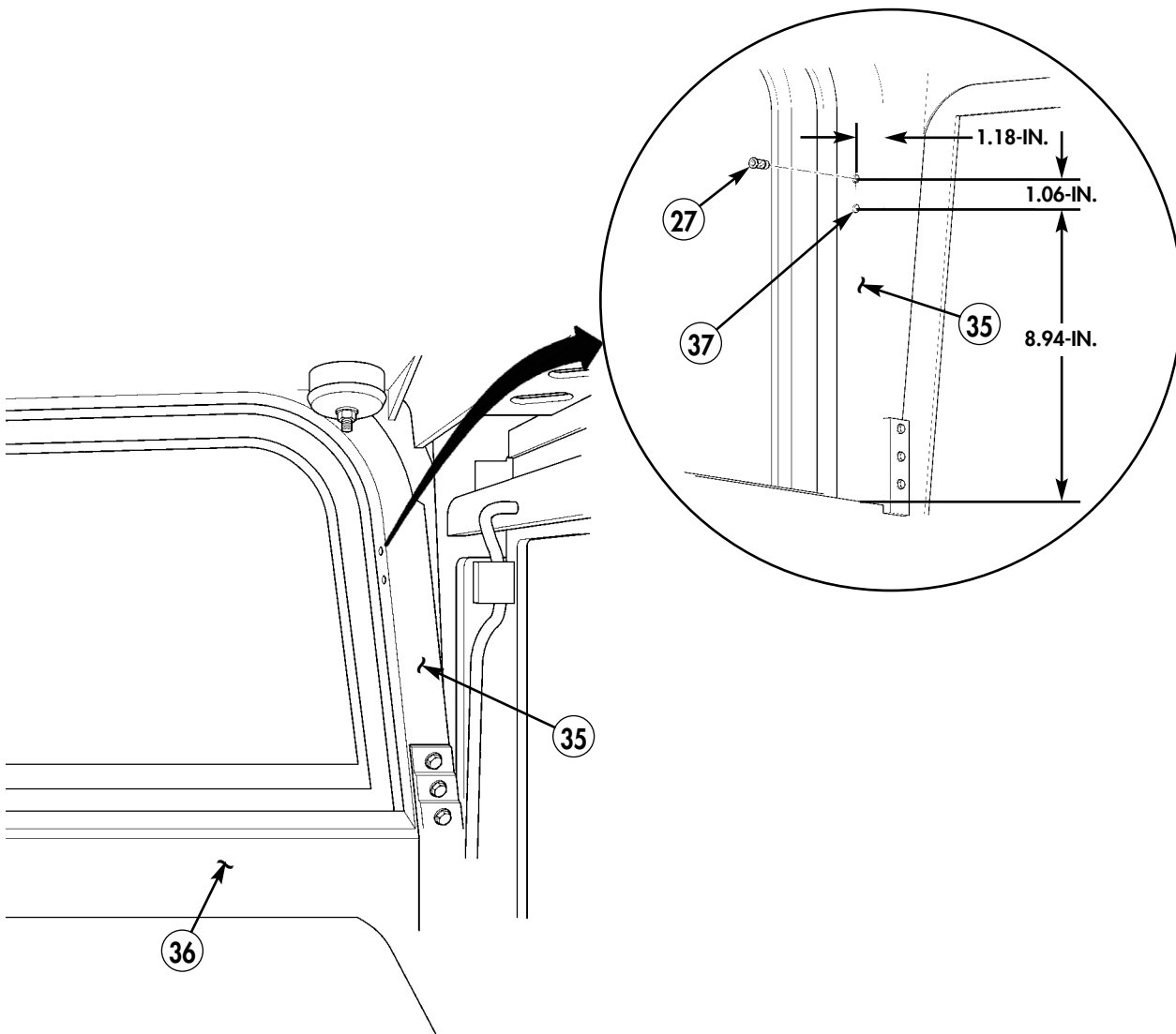

Figure 5-37.

- 4-26. Locate, mark, and drill two 0.297-in. diameter holes (37) in right-side windshield frame (35).
- 4-27. Install two inserts (27) in right-side windshield frame (35).
- 4-28. Install installation mount (39) on mounting bracket (41) with four screws (38) and locknuts (40).
- 4-29. Install mounting bracket (41) and installation mount (39) on right-side windshield frame (35) with two screws (31) and lockwashers (32).
- 4-30. Connect DAGR data cable (42) to DAGR (43).
- 4-31. Pull two spring loaded mounting pins (44) on installation mount (39) and align mount points (45) on DAGR (43) to installation mount (39) and seat properly.



27. INSERT - 12446871-3 - QTY. 2

Figure 5-38.

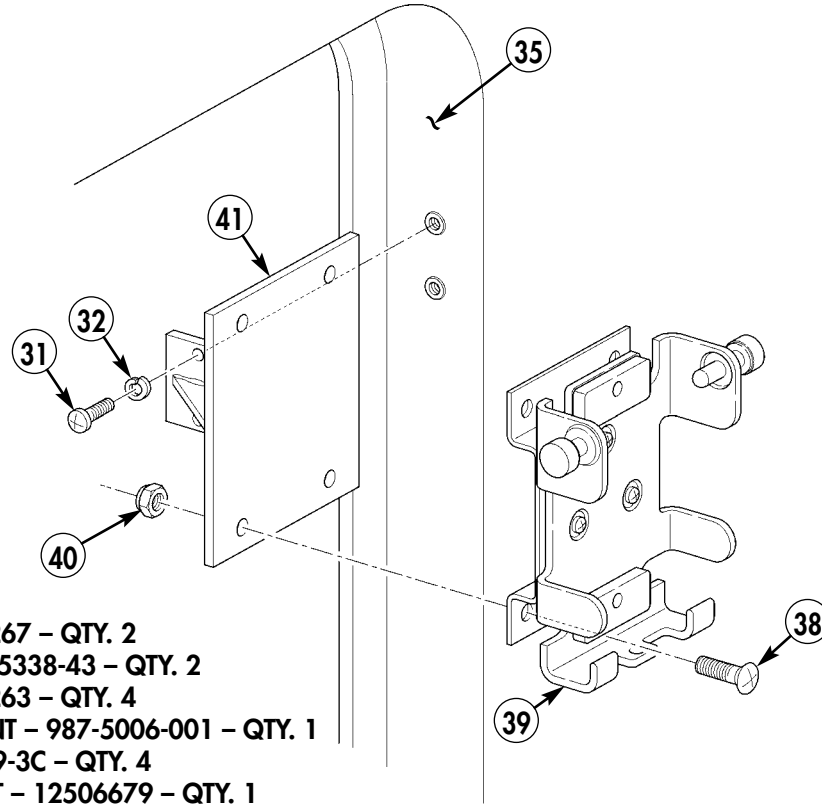

- 31. SCREW – MS35206-267 – QTY. 2
- 32. LOCKWASHER – MS35338-43 – QTY. 2
- 38. SCREW – MS35206-263 – QTY. 4
- 39. INSTALLATION MOUNT – 987-5006-001 – QTY. 1
- 40. LOCKNUT – MS17829-3C – QTY. 4
- 41. MOUNTING BRACKET – 12506679 – QTY. 1

Figure 5-39.

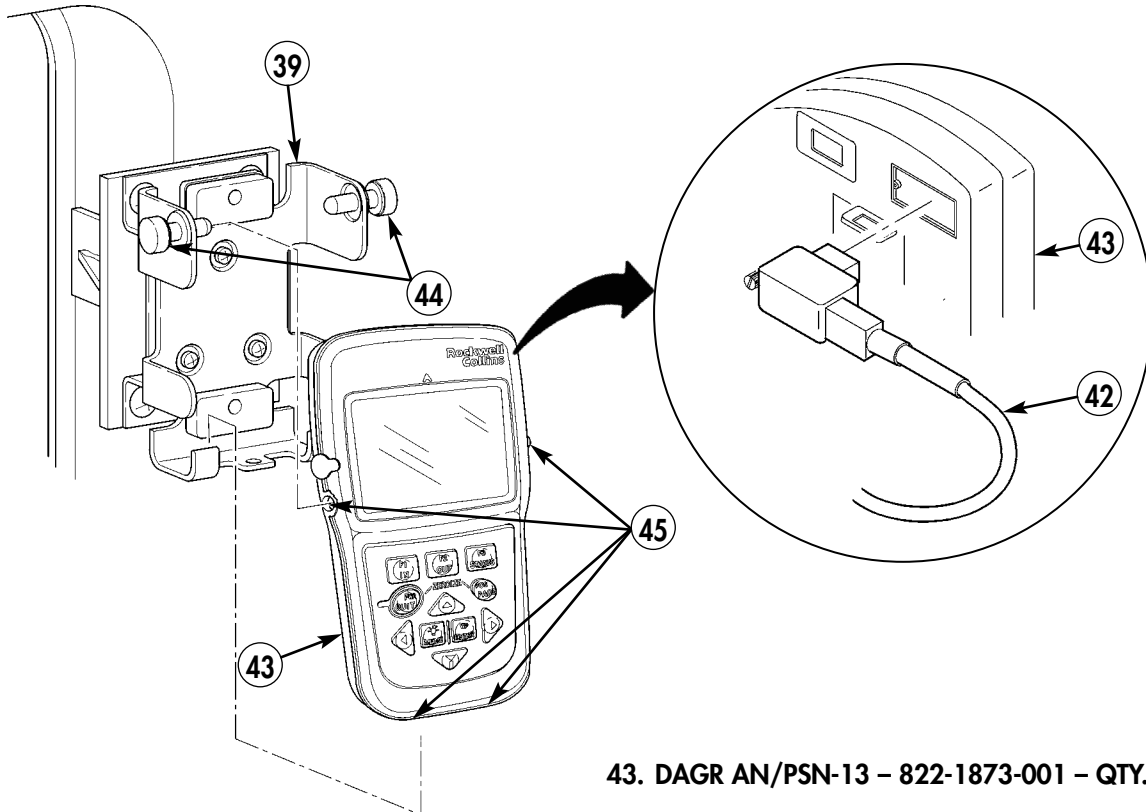

- 43. DAGR AN/PSN-13 – 822-1873-001 – QTY. 1

Figure 5-40.

4-32. Route DAGR antenna cable (21) behind insulation (46), along A-pillar (47).

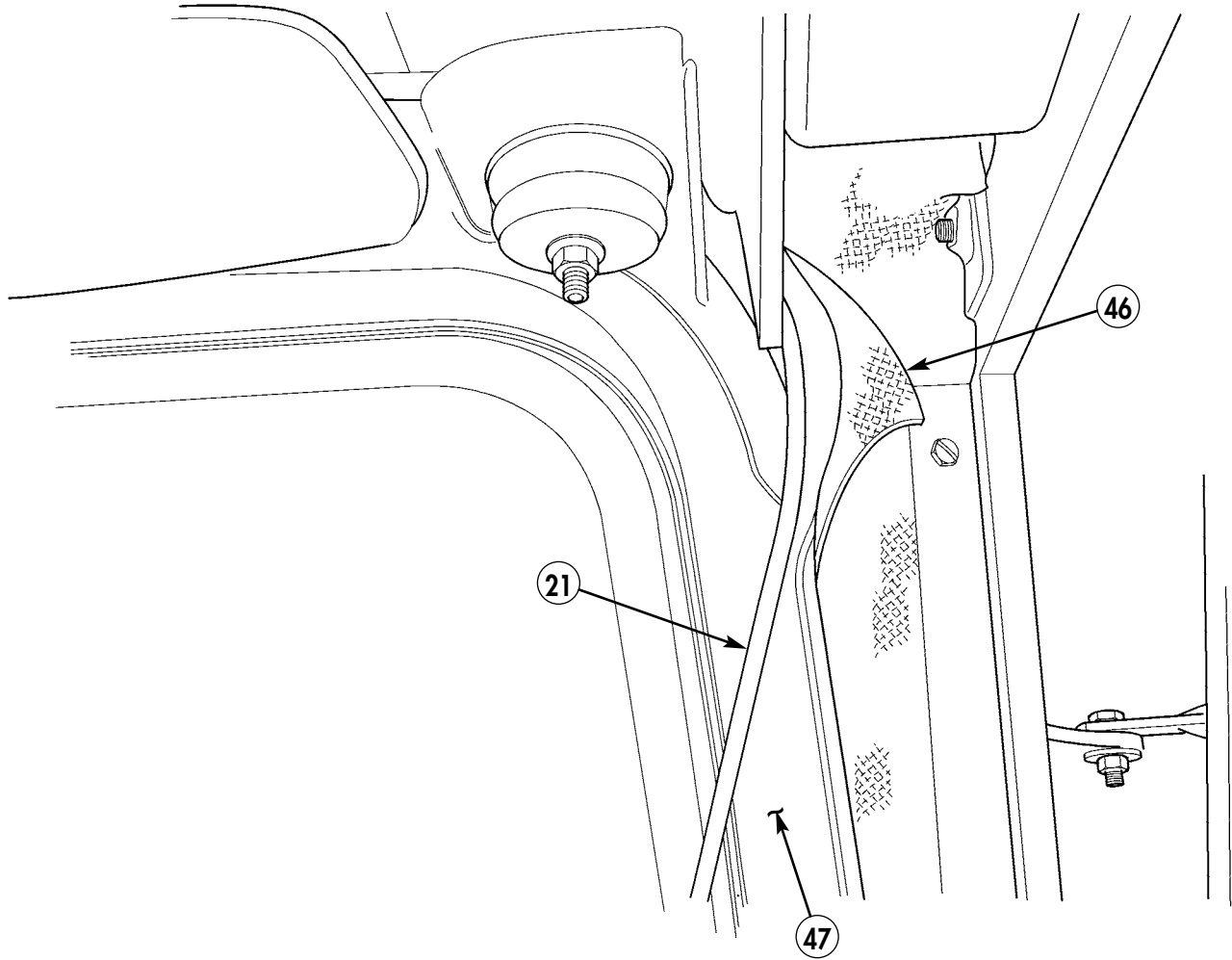

Figure 5-41.

4-33. Route DAGR antenna cable (21) along A-pillar (47) towards dashboard (55).

NOTE

Route BFT cable if necessary.

4-34. Secure DAGR antenna cable (21) and DAGR power cable (56) to A-pillar (47) with clamp (50), existing screw (52), lockwasher (53), and washer (54).

NOTE

Leave DAGR power cable in position until connection is made in Section XIV

4-35. Secure DAGR antenna cable (21) and DAGR power cable (56) to A-pillar (47) with clamp (50), existing screw (51), two washers (48), and locknut (49).

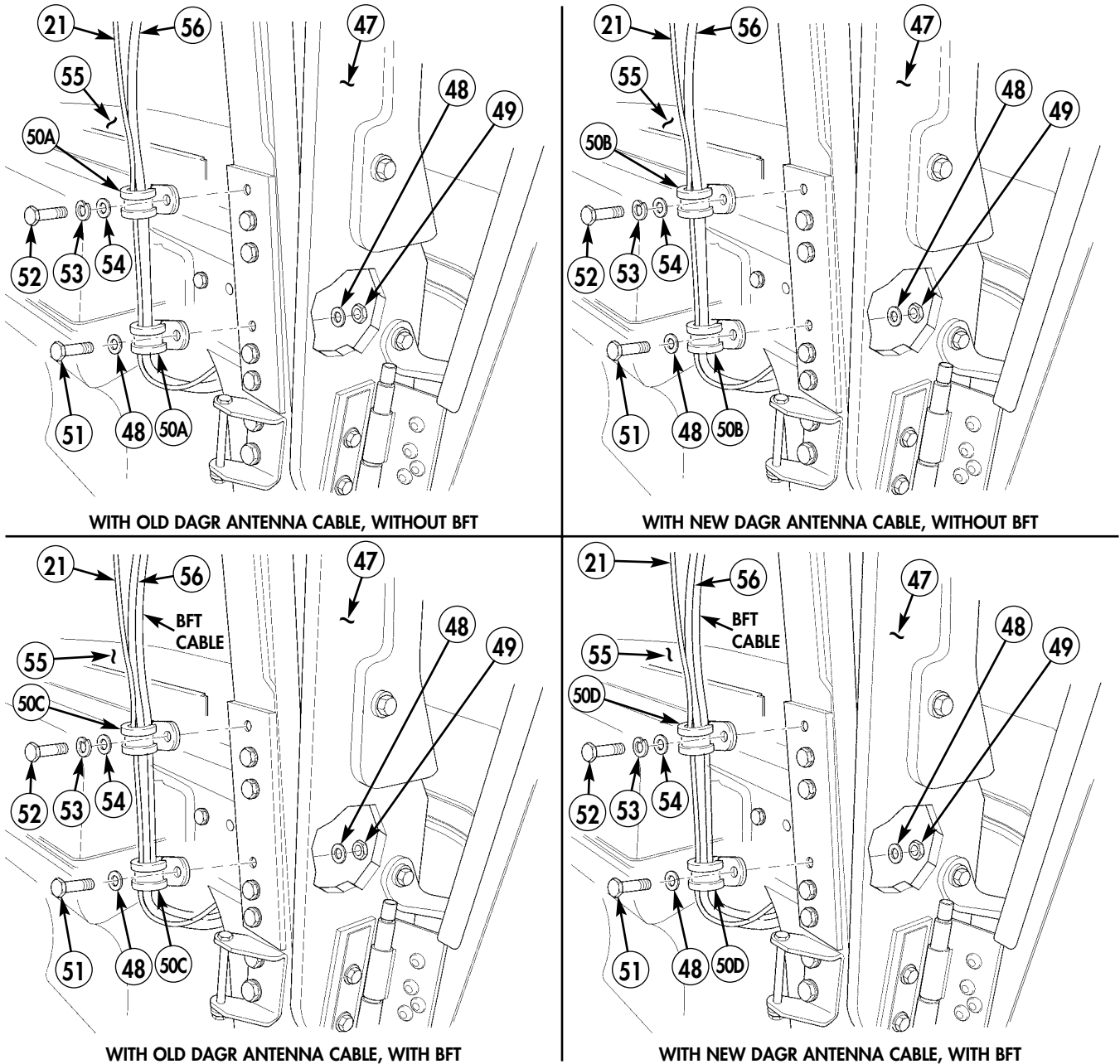

- 49. LOCKNUT - M45913/4-5CG8Z - QTY. 1
- 50A. CLAMP - MS21333-108 - QTY. 2
- 50B. CLAMP - MS21333-110 - QTY. 2

- 50C. CLAMP - MS21333-111 - QTY. 2
- 50D. CLAMP - MS21333-112 - QTY. 2
- 53. LOCKWASHER - MS35338-45 - QTY. 1

Figure 5-42.

- 4-36. Connect DAGR power cable (56) to J4 terminal (58) of DAGR (43).
- 4-37. Route DAGR antenna cable (21) to DAGR (43).
- 4-38. Connect DAGR antenna cable (21) to J3 terminal (57) on DAGR (43).
- 4-39. Secure excess DAGR antenna cable (21) to upper evaporator mounting bracket screw (61) on right floorboard (60) with clamp (62), nut (63), and two tie-down straps (59).

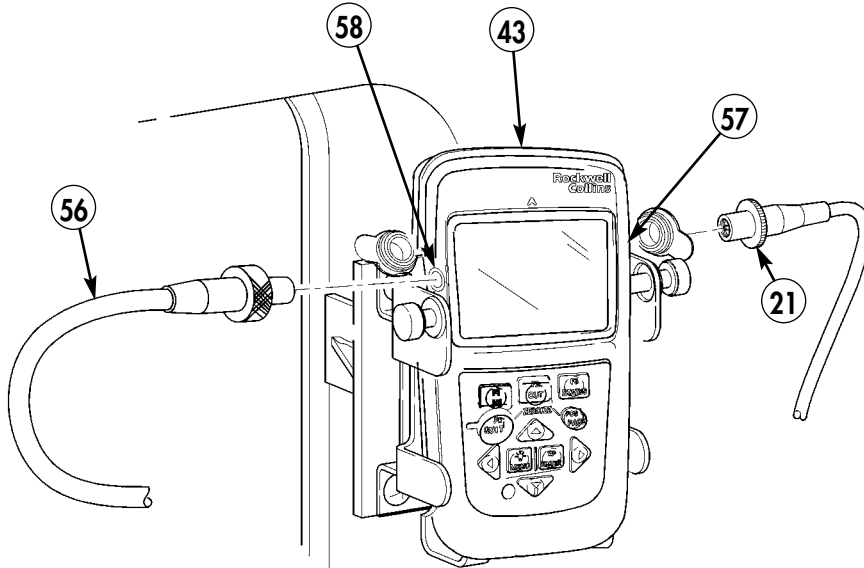

56. DAGR POWER CABLE – 987-5019-001 – QTY. 1

Figure 5-43.

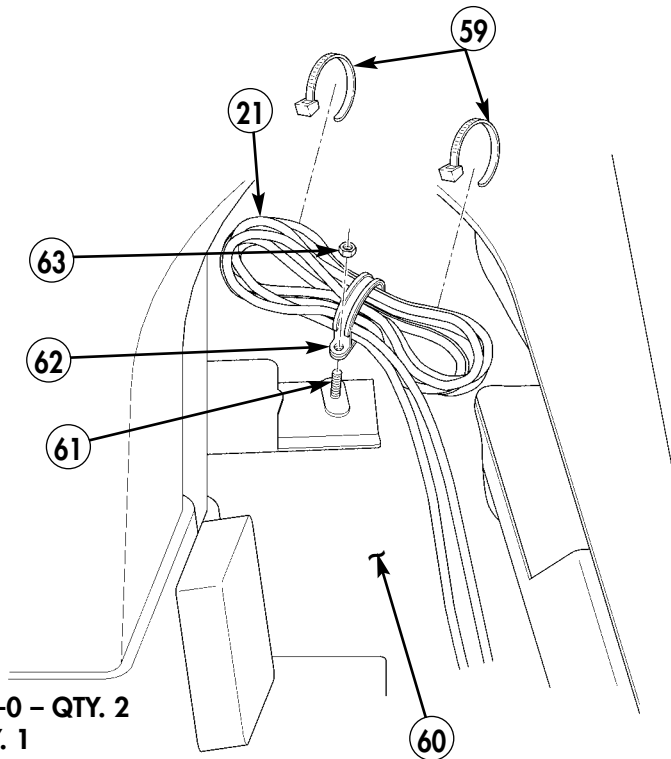

59. STRAP, TIEDOWN – MS3367-1-0 – QTY. 2
62. CLAMP – MS21333-129 – QTY. 1
63. NUT – MS51967-6 – QTY. 1

Figure 5-44.

Section V. BFT INSTALLATION

NOTE

- Perform either BFT installation or EPLRS installation. For EPLRS installation, see sections VI through X.
- Leave enough slack to connect cables to transceiver DAGR antenna.

- 5-1.** Route transceiver cable (2) with DAGR cable (3) through gap in armor plate (4), over grommet (1), to inside of vehicle.

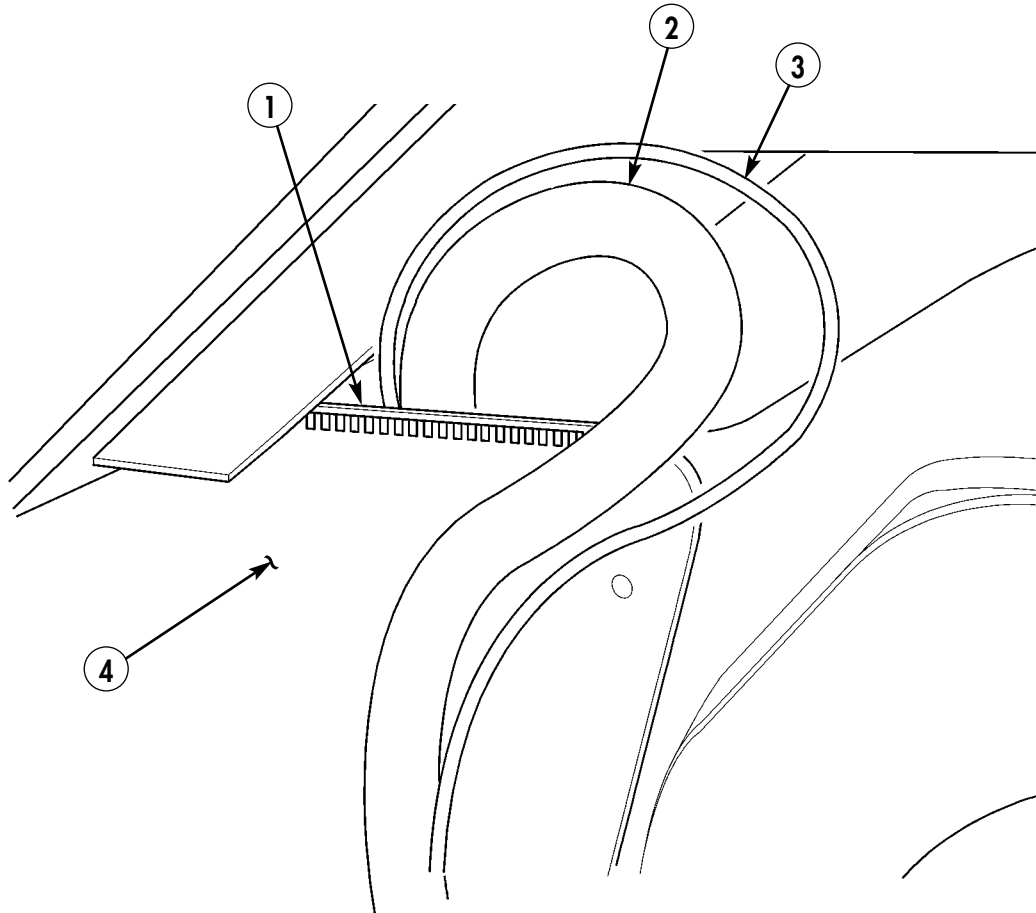

2. TRANSCEIVER CABLE – A1-35997D – QTY. 1

Figure 5-45.

- 5-2. Remove two capscrews (8), lockwashers (7), and washers (6) from vehicle (5). Discard two capscrews (8) and lockwashers (7).
- 5-3. Install transceiver bracket (9) on vehicle (5) with two capscrews (8), lockwasher (7), and washer (6).

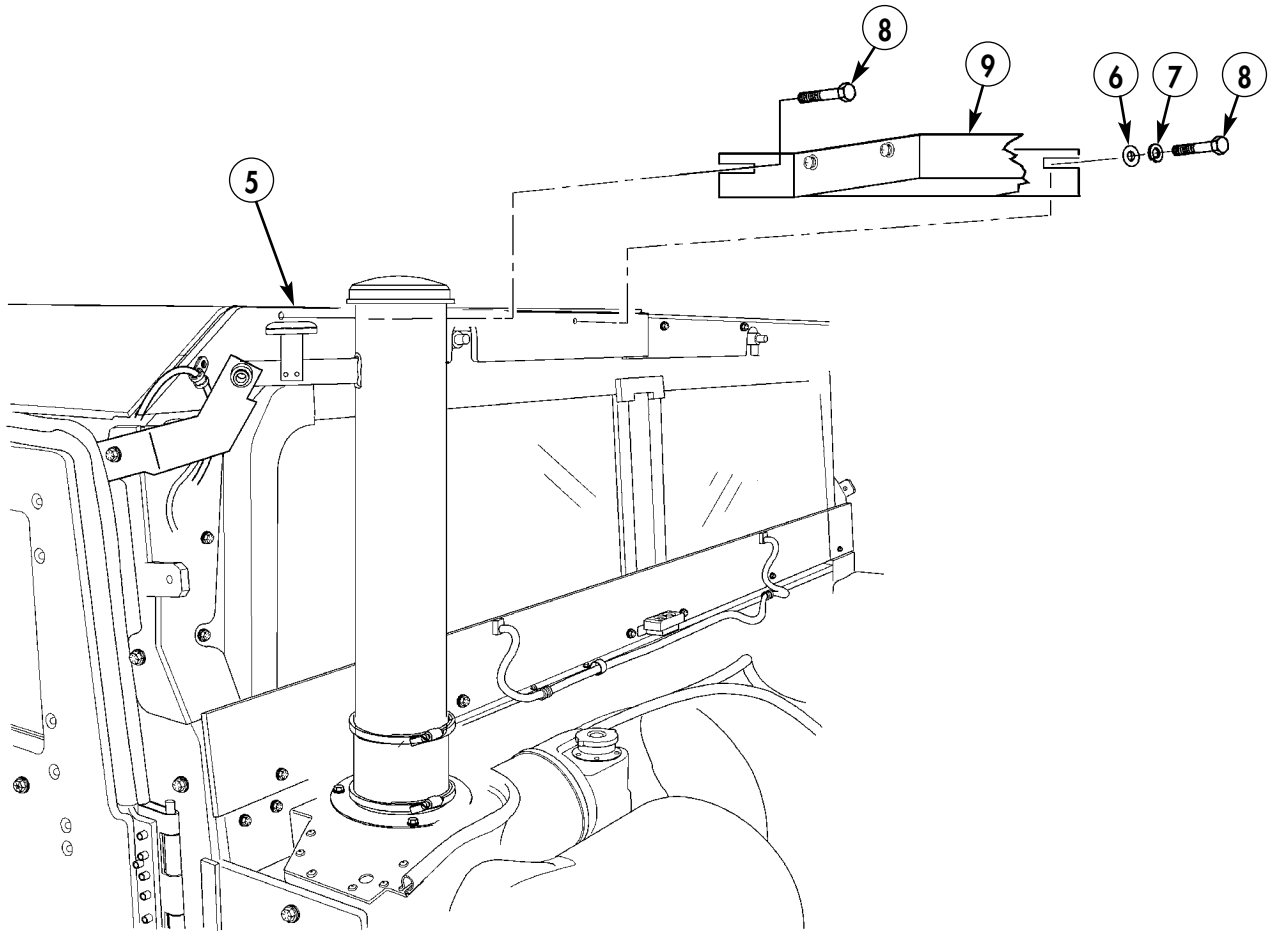

- 7. LOCKWASHER – MS35338-44 – QTY. 1
- 8. CAPSCREW – B1821BH025C125N – QTY. 2
- 9. TRANSCEIVER BRACKET – A1-38239D – QTY. 1

Figure 5-46.

- 5-4. Install transceiver (10) on transceiver bracket (9) with two screws (13), lockwashers (12), washers (11), screws (13), lockwashers (12), washers (11), and locking bracket (15).
- 5-5. Install locking bar (16) on locking bracket (15) and secure with padlock (14).

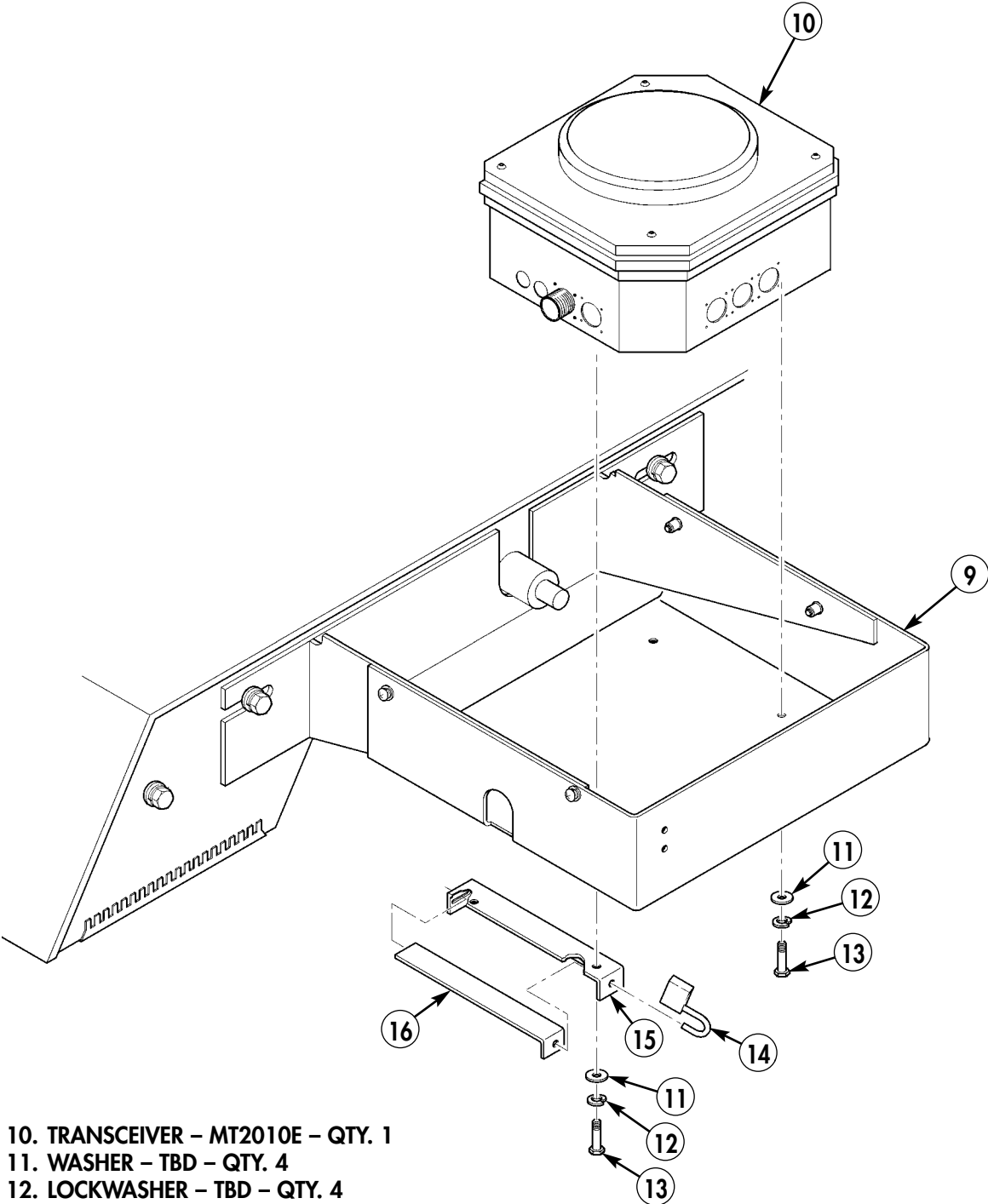

- 10. TRANSCEIVER – MT2010E – QTY. 1
- 11. WASHER – TBD – QTY. 4
- 12. LOCKWASHER – TBD – QTY. 4
- 13. SCREW – TBD – QTY. 4
- 14. PADLOCK – TBD – QTY. 1
- 15. LOCKING BRACKET – TBD – QTY. 1
- 16. LOCKING BAR – TBD – QTY. 1

Figure 5-47.

- 5-6. Connect connector (20) of transceiver cable (2) to transceiver connector (19).

NOTE

Ensure all slack in cable is inside vehicle.

- 5-7. Remove screw (8) from right side roof armor (17).
5-8. Route transceiver cable (2) along right side roof armor (17) with clamp (18), existing screw (8), lockwasher (7), and existing washer (6).

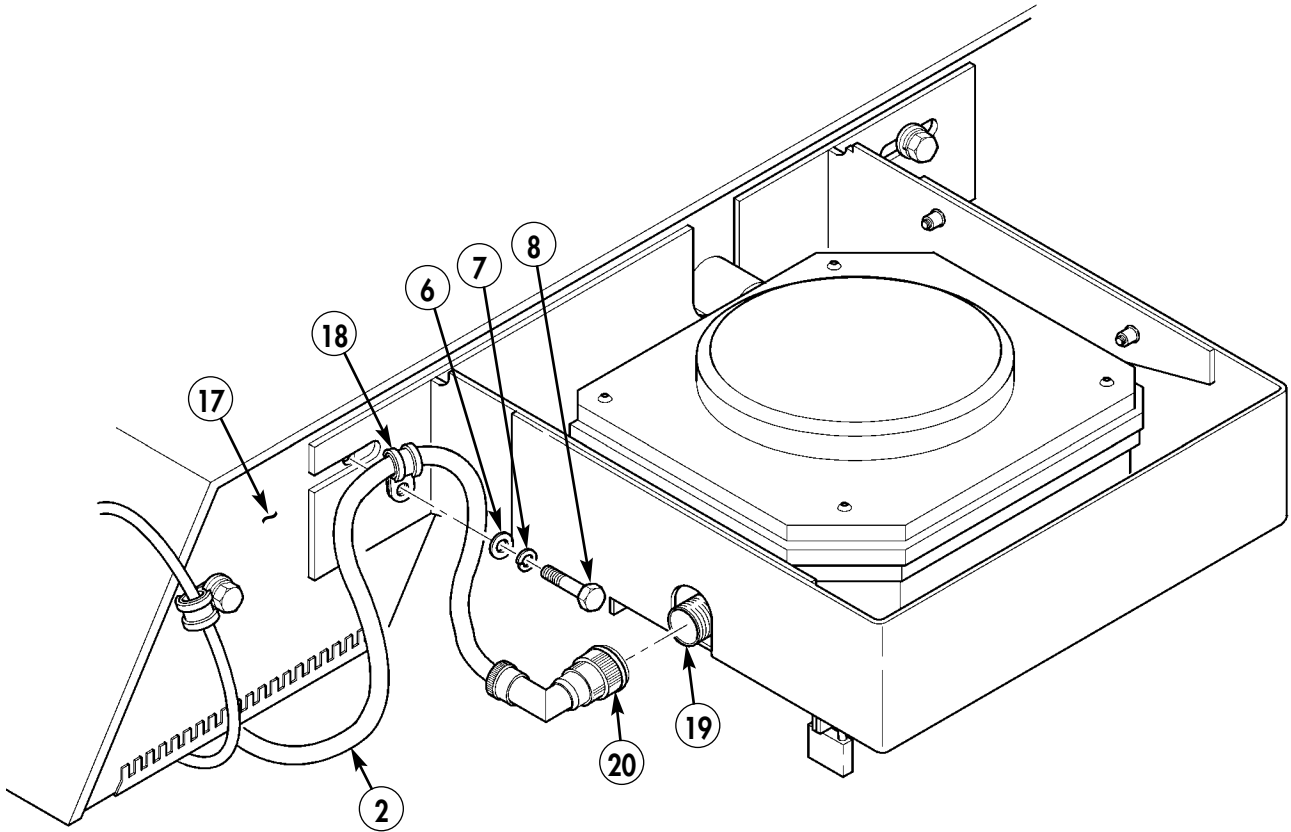

7. LOCKWASHER – MS35338-44 – QTY. 1
18. CLAMP, LOOP – MS21333-101 – QTY. 1

Figure 5-48.

- 5-9. Remove screw (24) and air conditioning close out panel (23) from air conditioning duct (22).
- 5-10. Route transceiver cable (2) behind air conditioning duct (22) to radio rack (21).
- 5-11. Install air conditioning close out panel (23) on air conditioning duct (22) with screw (24).

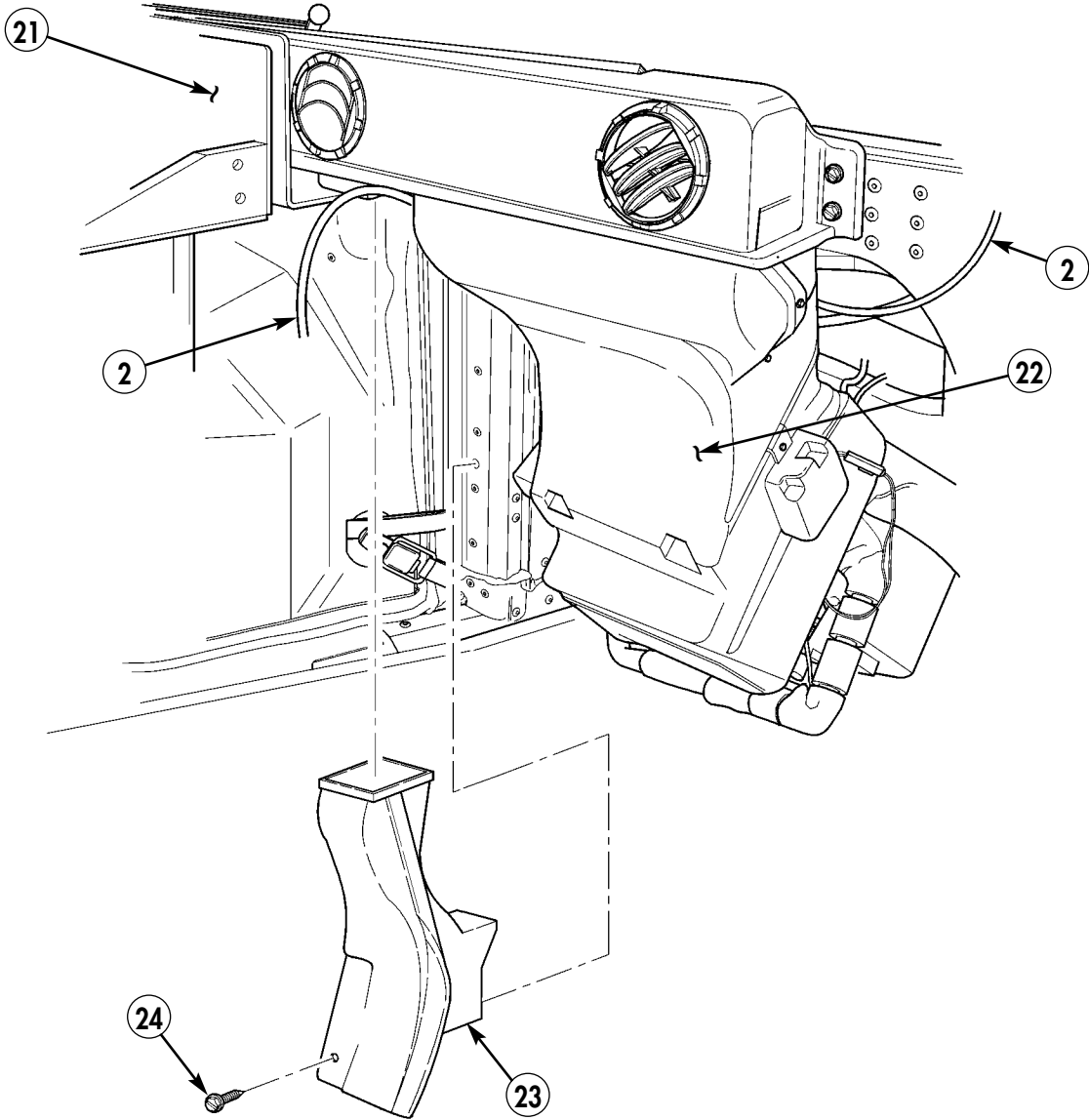

Figure 5-49.

NOTE

Previously installed equipment not shown for clarity.

- 5-12. Remove screws (26) from lid (25) of antenna switch box (27).
- 5-13. Route Data/Power with terminal ends (29) of transceiver cable (2) between radio rack (21) and engine cover (32) through radio rack access hole (28).
- 5-14. Insert Data/Power with terminal ends (29) of transceiver cable (2) into antenna switch box (27).
- 5-15. Route Data leg with connector end (35) of transceiver cable (2) between radio rack (21) and engine cover (32) through rear radio rack access hole (28).
- 5-16. Connect Data leg connector (35) of transceiver cable (2) to J3 connector (34) of SIAD (33).
- 5-17. Insert power cable with terminal ends (31) into antenna switch box (27).
- 5-18. Route power cable (31) through radio rack access hole (28) and to tunnel insulation (30).
- 5-19. Remove nut (37) and washer (38) from stud (41) in antenna switch box (27).
- 5-20. Connect negative lead (39) of Data/Power with terminal ends (29) of transceiver cable (2) to stud (41) in antenna switch box (27).
- 5-21. Connect negative lead (40) of power cable (31) to stud (41) in antenna switch box (27).
- 5-22. Secure negative leads (39) and (40) to stud (41) with existing washer (38) and nut (37).
- 5-23. Install positive lead (44) of Data/Power with terminal ends (29) of transceiver cable (2) to antenna switch (36) with existing screw (45).
- 5-24. Install positive lead (43) of power cable (31) to antenna switch (36) with existing screw (42).
- 5-25. Install lid (25) on antenna switch box (27) with screws (26).

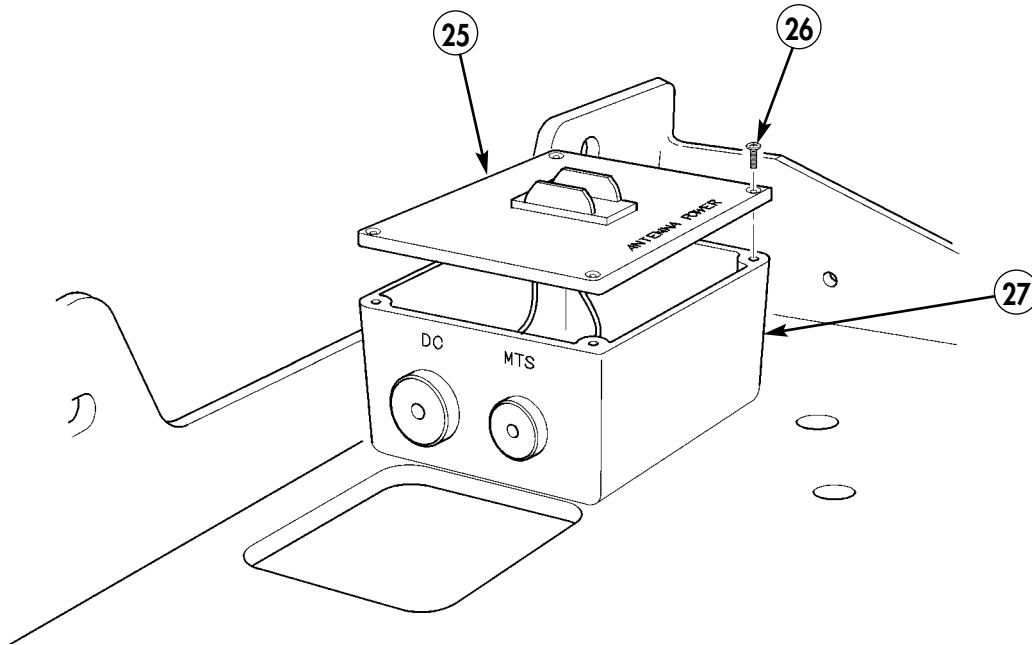
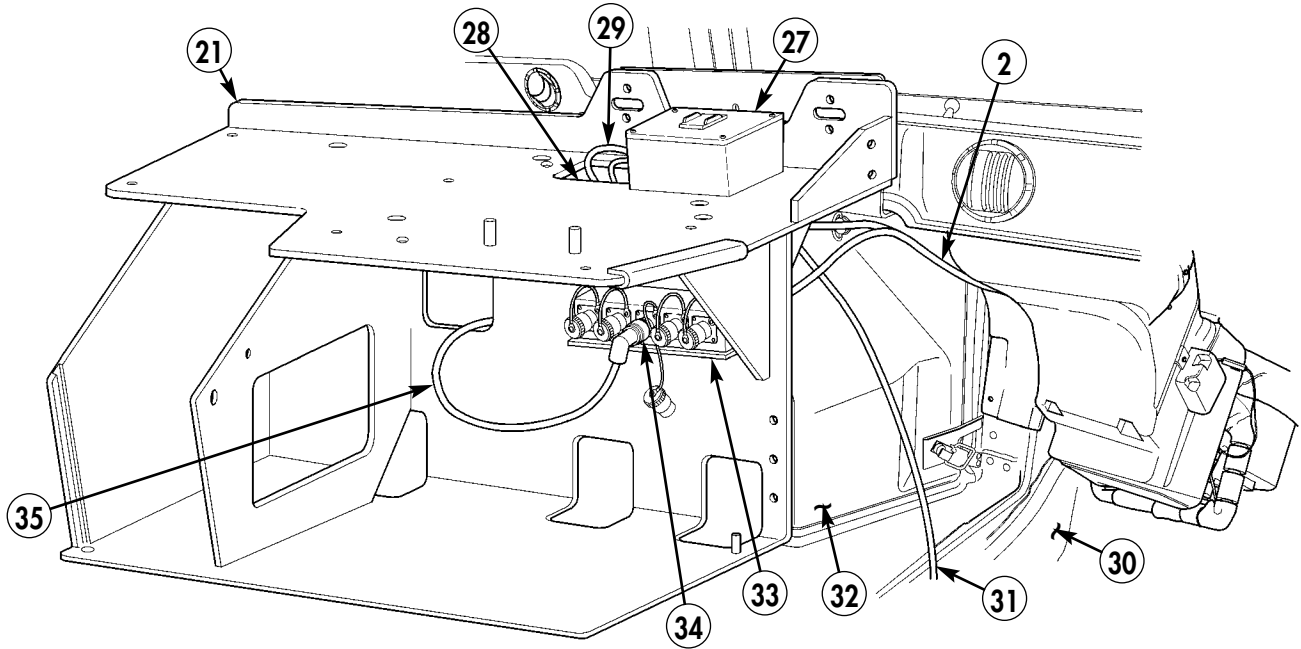

Figure 5-50.



- 29. MTS/V4/POWER CABLE - A1-35997D - QTY. 1
- 31. DC POWER CABLE - A1-35997D - 36004D-003 - QTY. 1

Figure 5-51.

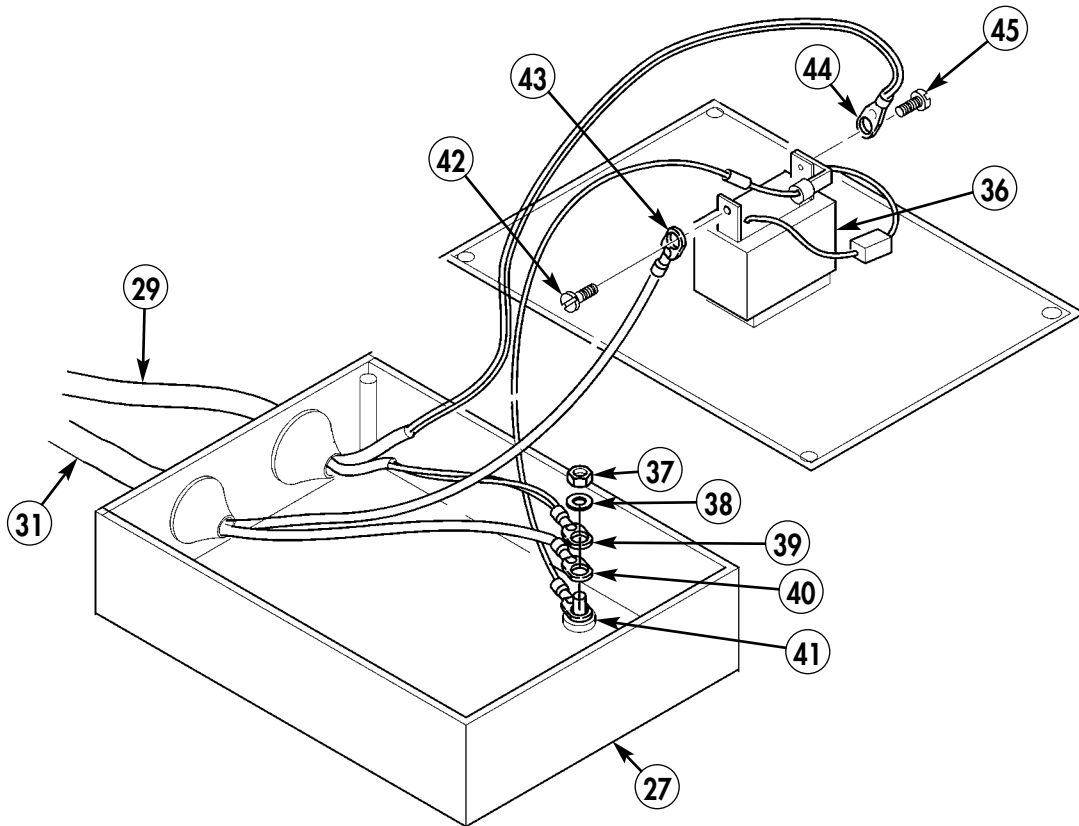

Figure 5-52.

Section VI. INTERFACE PLATE INSTALLATION

NOTE

- Perform Section VI if interface plate is not installed.
- Perform either BFT installation or EPLRS installation. For BFT installation, see section V.

- 6-1.** Remove ten capscrews (1), lockwashers (2), and washers (3) from left side wheelhouse (4).
- 6-2.** Install interface plate (6) on left side wheelhouse (4) with two existing capscrews (1), lockwashers (2), and washers (3). Do not tighten capscrews (1) at this time.
- 6-3.** Secure interface plate (6) to left side wheelhouse (4) with eight screws (5).
- 6-4.** Tighten capscrews (1) and screws (5) to 6 lb-ft. (8 N•m).

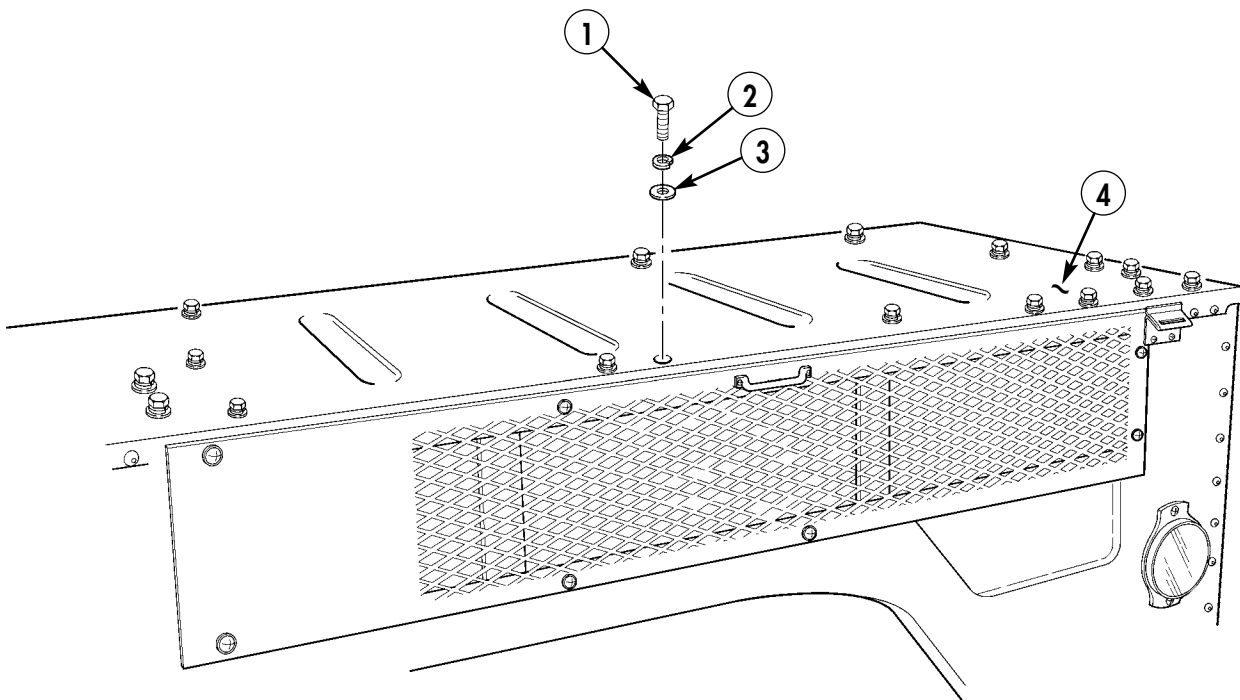
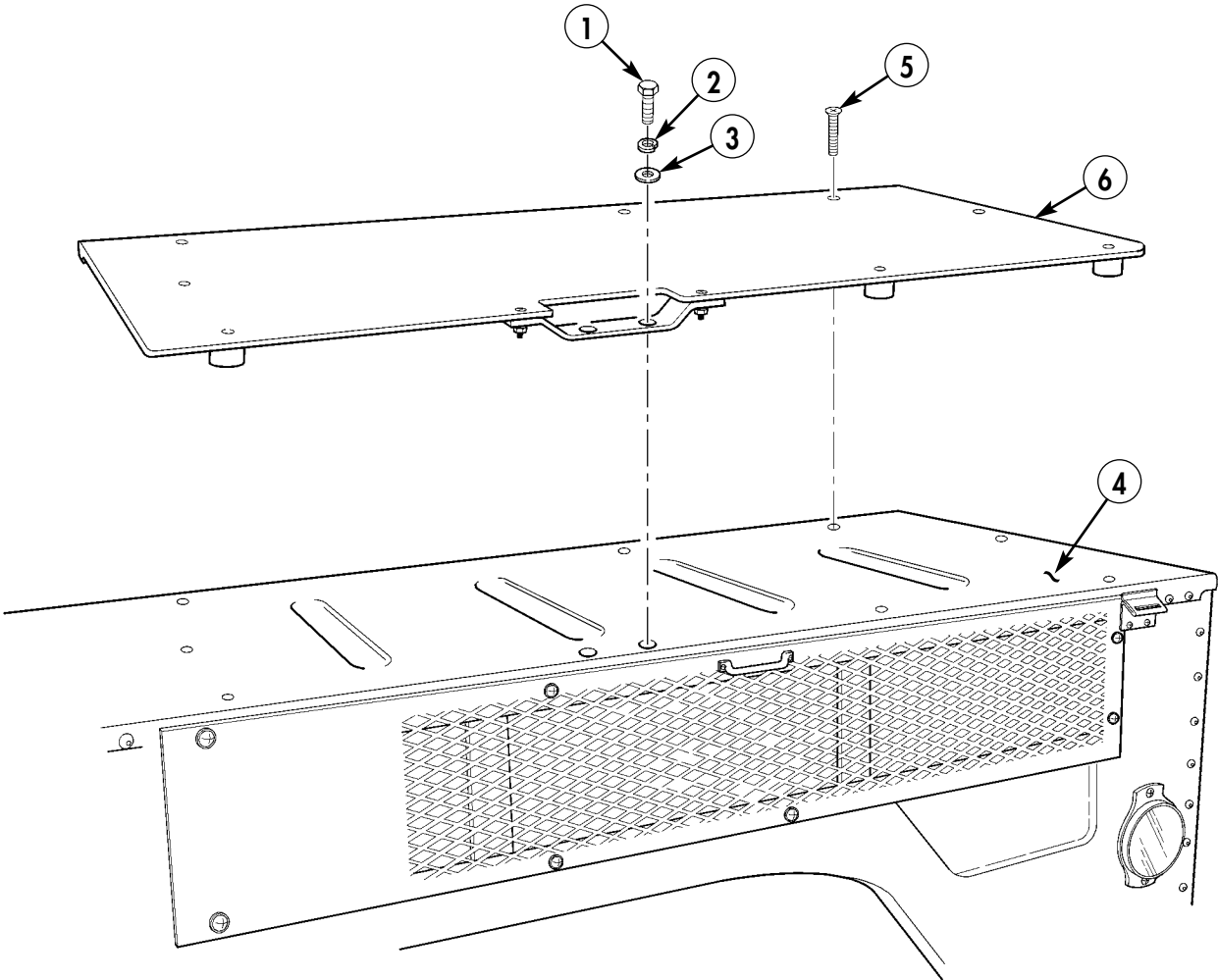

Figure 5-53.



- 2. LOCKWASHER - MS35338-44 - QTY. 2
- 5. SCREW - MS24667-35 - QTY. 8
- 6. INTERFACE PLATE - 12506814 - QTY. 1

Figure 5-54.

Section VII. EPLRS RESILIENT MOUNT INSTALLATION

NOTE

Perform either BFT installation or EPLRS installation. For BFT installation, see section V.

- 7-1. Position EPLRS resilient mount (1) on left side interface plate (2).
- 7-2. Using EPLRS resilient mount (1) as template, locate and mark four hole positions (6) in left side interface plate (2).
- 7-3. Remove EPLRS resilient mount (1) from left side interface plate (2).
- 7-4. Drill four 0.531-in. diameter holes (6) in left side interface plate (2).
- 7-5. Install four inserts (5) in holes (6) in left side interface plate (2).
- 7-6. Install EPLRS resilient mount (1) on left side interface plate (2) with four capscrews (3) and lockwashers (4).
- 7-7. Install EPLRS unit (7) in EPLRS mount (1).
- 7-8. Connect ground leads (8) to EPLRS unit (7).

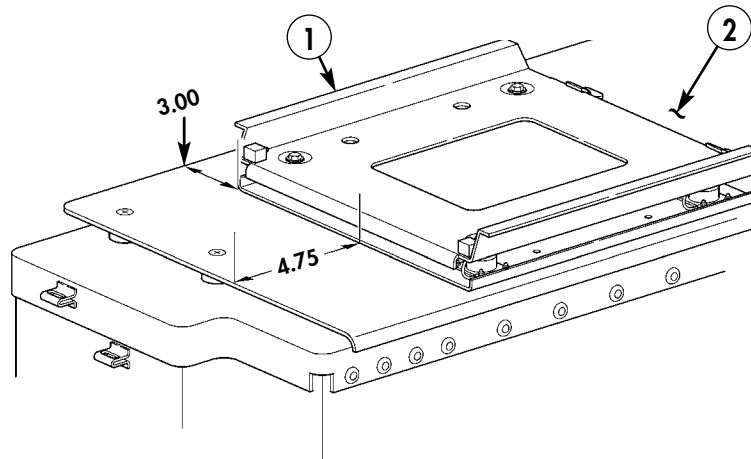

1. RESILIENT MOUNT – MT-6146/VSQ-1 – QTY. 1

Figure 5-55.

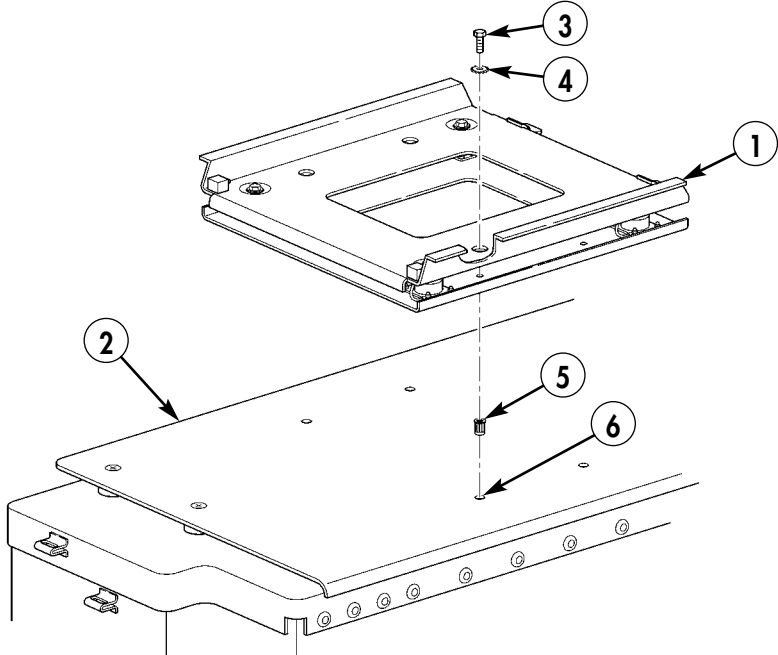

- 3. CAPSCREW - B1821BH031C100N - QTY. 4
- 4. LOCKWASHER - MS45904-72 - QTY. 4
- 5. INSERT - 12446871-15 - QTY. 4

Figure 5-56.

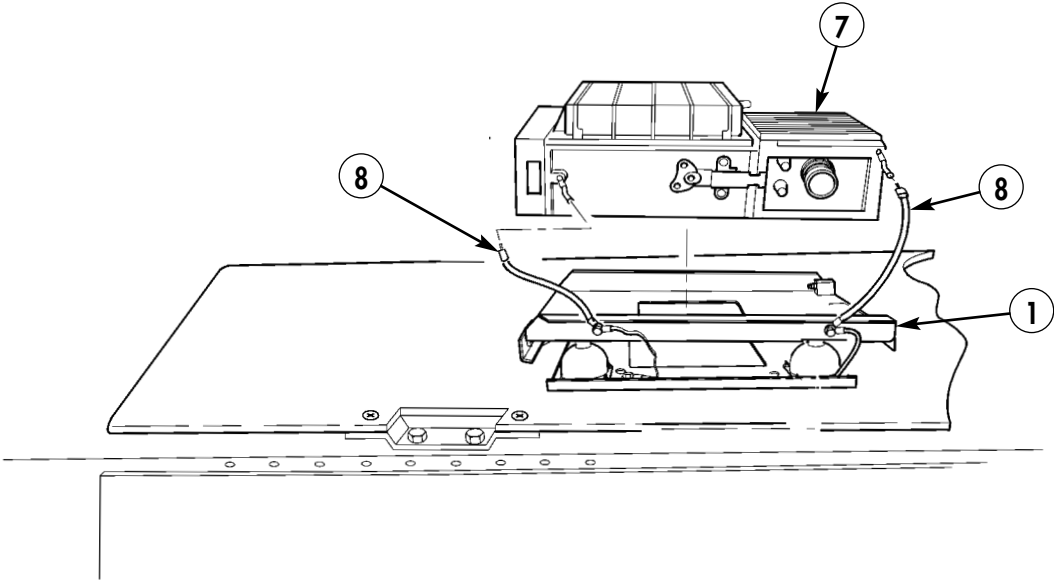

Figure 5-57.

Section VIII. URO MOUNTING BRACKET INSTALLATION

NOTE

Perform either BFT installation or EPLRS installation. For BFT installation, see section V.

- 8-1. Position URO bracket (1) on left side interface plate (2). Locate and mark four hole positions (7) in left side interface plate (2).
- 8-2. Remove URO bracket (1) from left side interface plate (2).
- 8-3. Drill four 0.295-in. diameter holes (7) in interface plate (2).
- 8-4. Install four inserts (6) in left side interface plate (2).
- 8-5. Install URO bracket (1) on left side interface plate (2) with four capscrews (3), lockwashers (4), and washers (5).

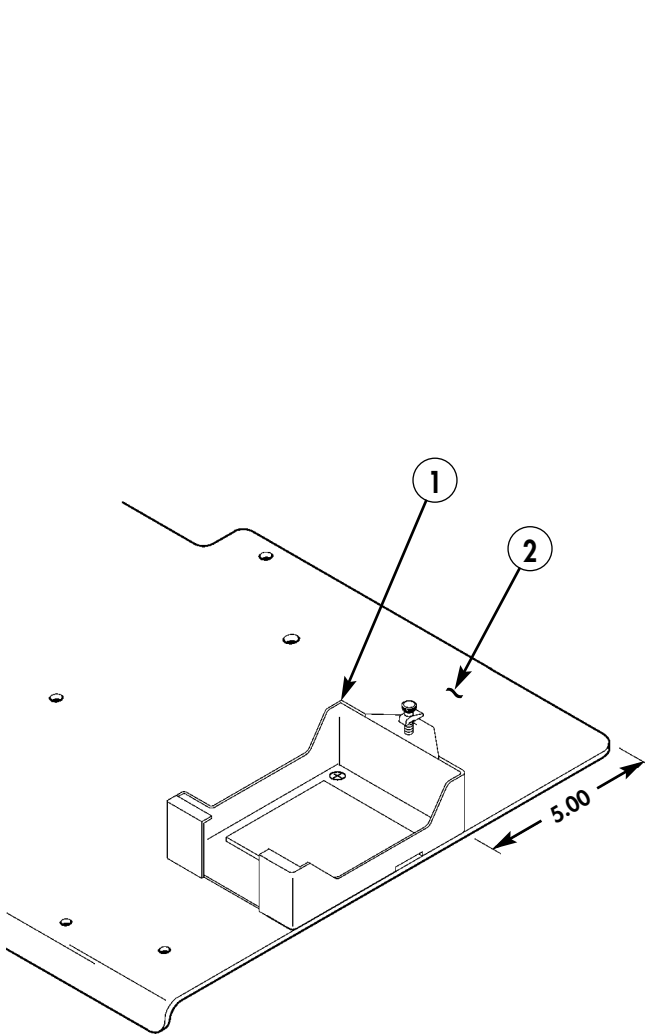

1. USER READOUT BRACKET (URO) – A3006206 – QTY. 1

Figure 5-58.

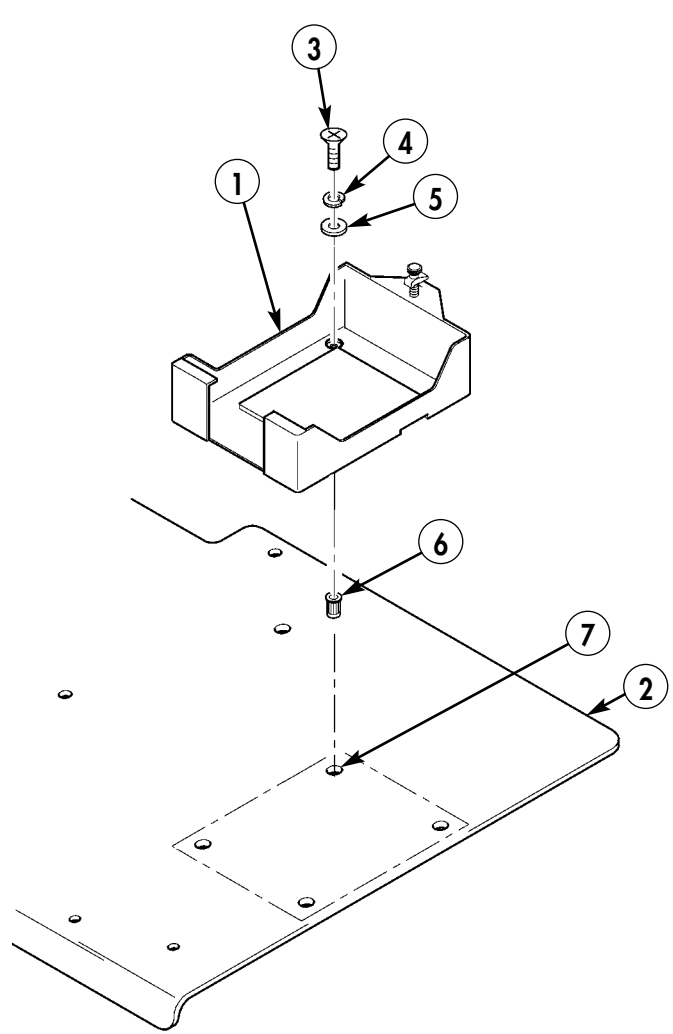

3. CAPSCREW – MS35206-266 – QTY. 4
 4. LOCKWASHER – MS35338-43 – QTY. 4
 5. WASHER – 9416128 – QTY. 4
 6. INSERT – 12446871-7 – QTY. 4

Figure 5-59.

Section IX. EPLRS ANTENNA INSTALLATION

- 9-1.** Assemble antenna mounting bracket (3) and antenna base reinforcement bracket (4) with eight capscrews (1), sixteen washers (2), eight lockwashers (5), and nuts (6). Do not tighten nuts (6) at this time.
- 9-2.** Remove paint from vicinity of all mounting holes on interface plate, antenna mount assembly, and ground strap. Apply anti-seize compound as required. (Refer to figure 5-60.)

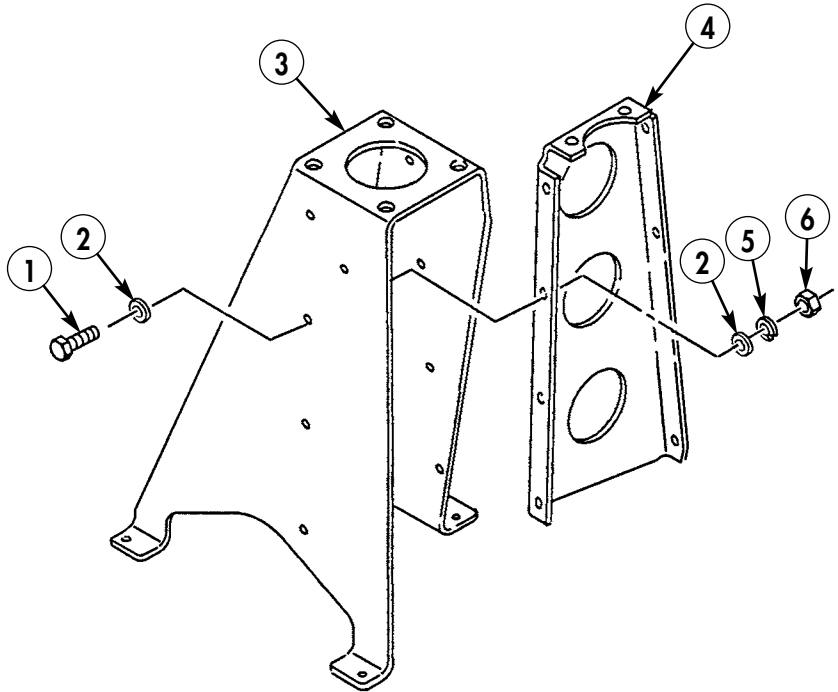

1. CAPSCREW – B1821BH025C125N – QTY. 8
 2. WASHER – 2436161 – QTY. 16
 3. ANTENNA MOUNTING BRACKET – A3046238 – QTY. 1
 4. ANTENNA BASE REINFORCEMENT BRACKET – A3046241 – QTY. 1
 5. LOCKWASHER – MS35338-44 – QTY. 8
 6. NUT – 9419143 – QTY. 8

Figure 5-60.

- 9-3. Using EPLRS antenna mount (3) as template, locate and mark five hole positions (10) in interface plate (11).
- 9-4. Remove EPLRS antenna mount (3) from interface plate (11).
- 9-5. Drill five 0.391-in. diameter holes (10) in interface plate (11).
- 9-6. Install five inserts (9) in interface plate (11).
- 9-7. Install EPLRS antenna mount (3) on interface plate (11) with five capscrews (7) and lockwashers (8).

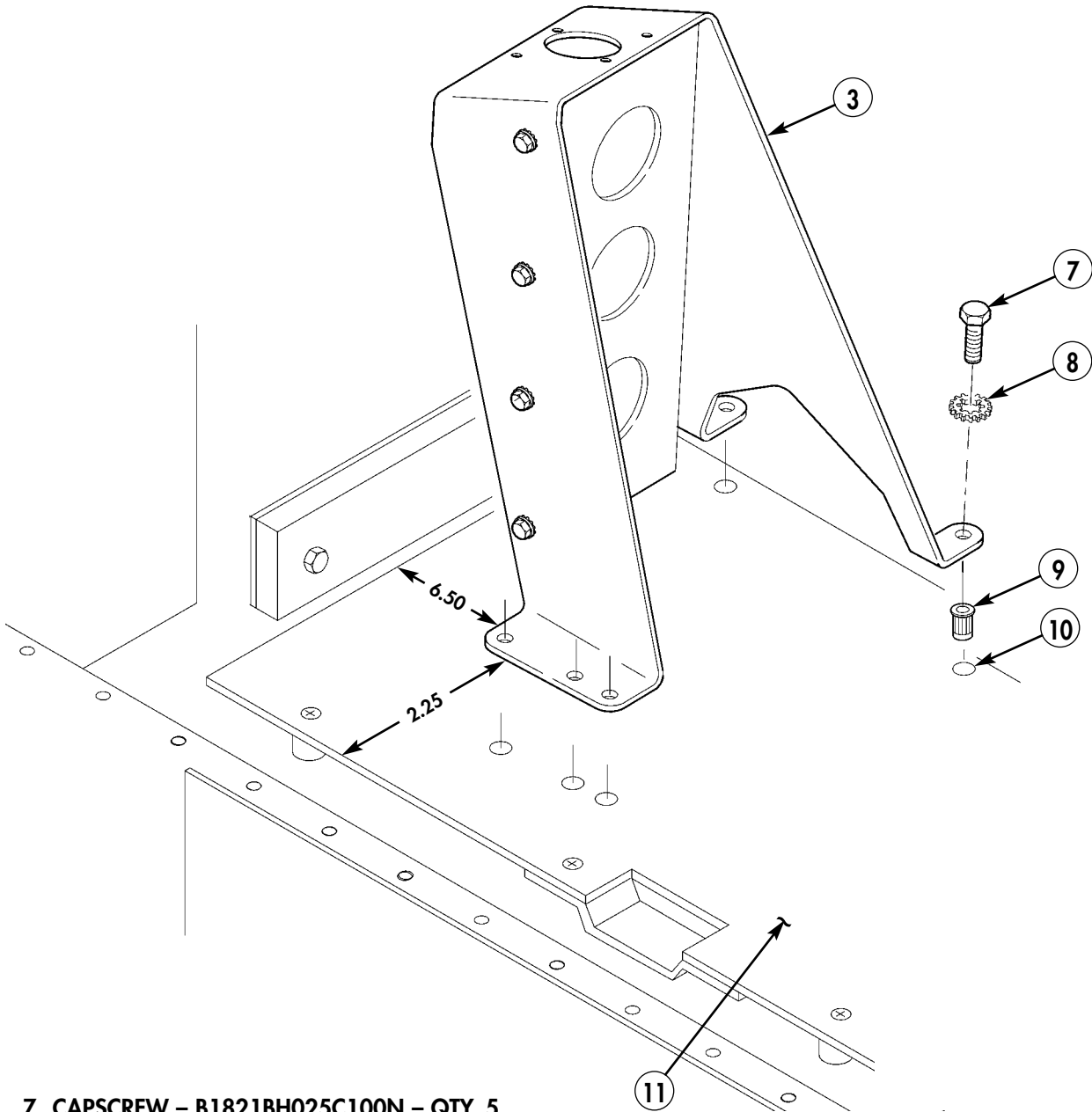

- 7. CAPSCREW – B1821BH025C100N – QTY. 5
- 8. LOCKWASHER – M545904-69 – QTY. 5
- 9. INSERT – 12446871-16 – QTY. 5

Figure 5-61.

NOTE

Perform step 9-8 only if not installing cargo soft-top enclosure; otherwise, skip to step 9-9.

- 9-8. Install antenna (13) on antenna mount assembly (3) with four capscrews (14), gasket (12), eight lockwashers (15), and four nuts (16).

NOTE

Perform steps 9-9 through 9-11 only when installing cargo soft-top enclosure.

- 9-9. Install cargo soft-top enclosure.

NOTE

Ensure all slack has been taken out of cargo soft-top enclosure and that cargo soft-top enclosure has been properly installed.

- 9-10. Using antenna mount assembly (3) as template, locate, mark, and drill four 0.375-in. holes (18) and cut "X" (19) in cargo soft-top enclosure (17).

- 9-11. Install antenna (13) on antenna mount assembly (3) and cargo soft-top enclosure (17) with four capscrews (14), gasket (12), eight lockwashers (15), and four nuts (16).

- 9-12. Tighten nuts (16).

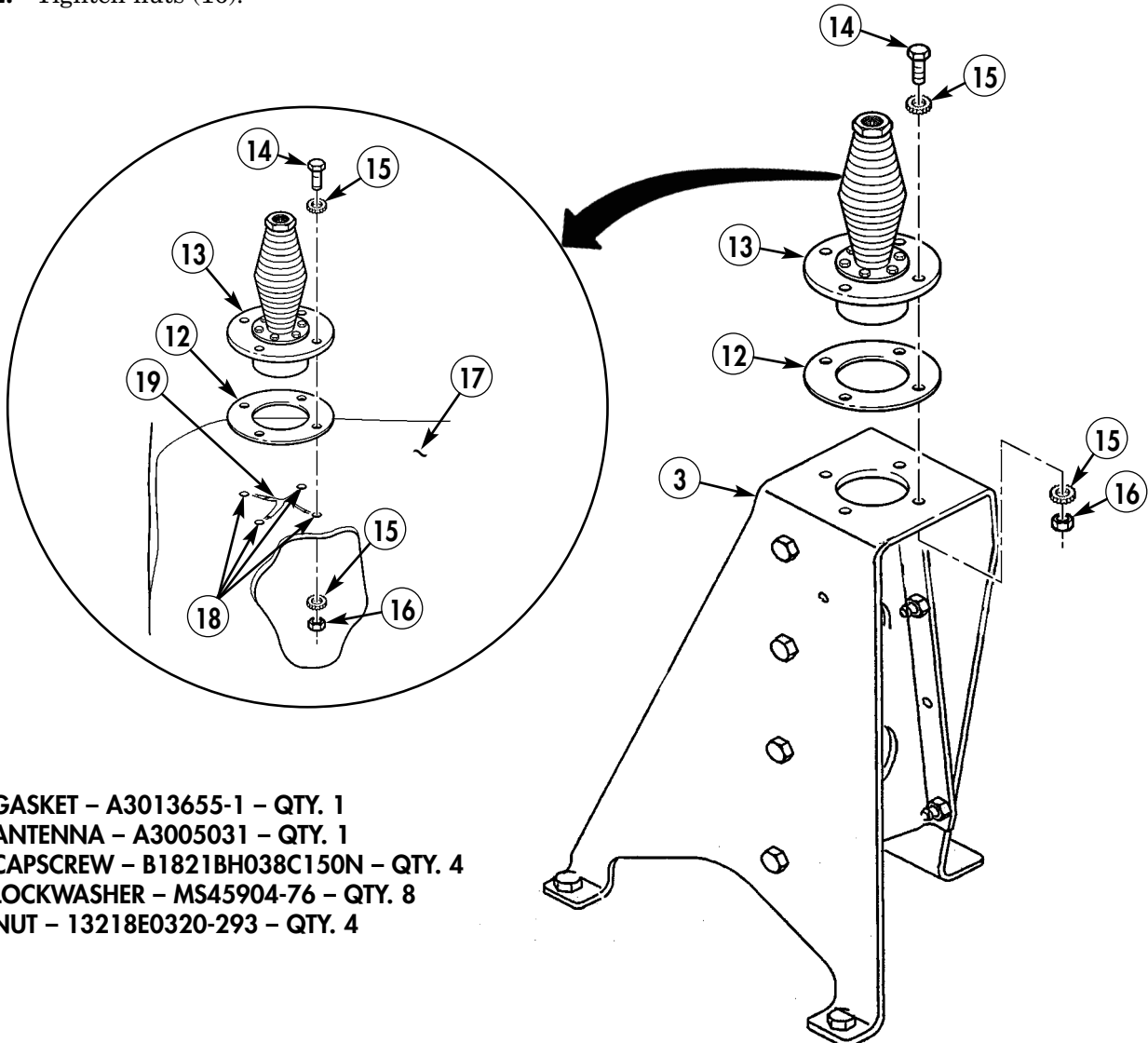

- 12. GASKET - A3013655-1 - QTY. 1
- 13. ANTENNA - A3005031 - QTY. 1
- 14. CAPSCREW - B1821BH038C150N - QTY. 4
- 15. LOCKWASHER - MS45904-76 - QTY. 8
- 16. NUT - 13218E0320-293 - QTY. 4

Figure 5-62.

Section X. EPLRS CABLES INSTALLATION

10-1. Locate, mark, and drill 1.75-in. diameter hole (2) in body of vehicle (1).

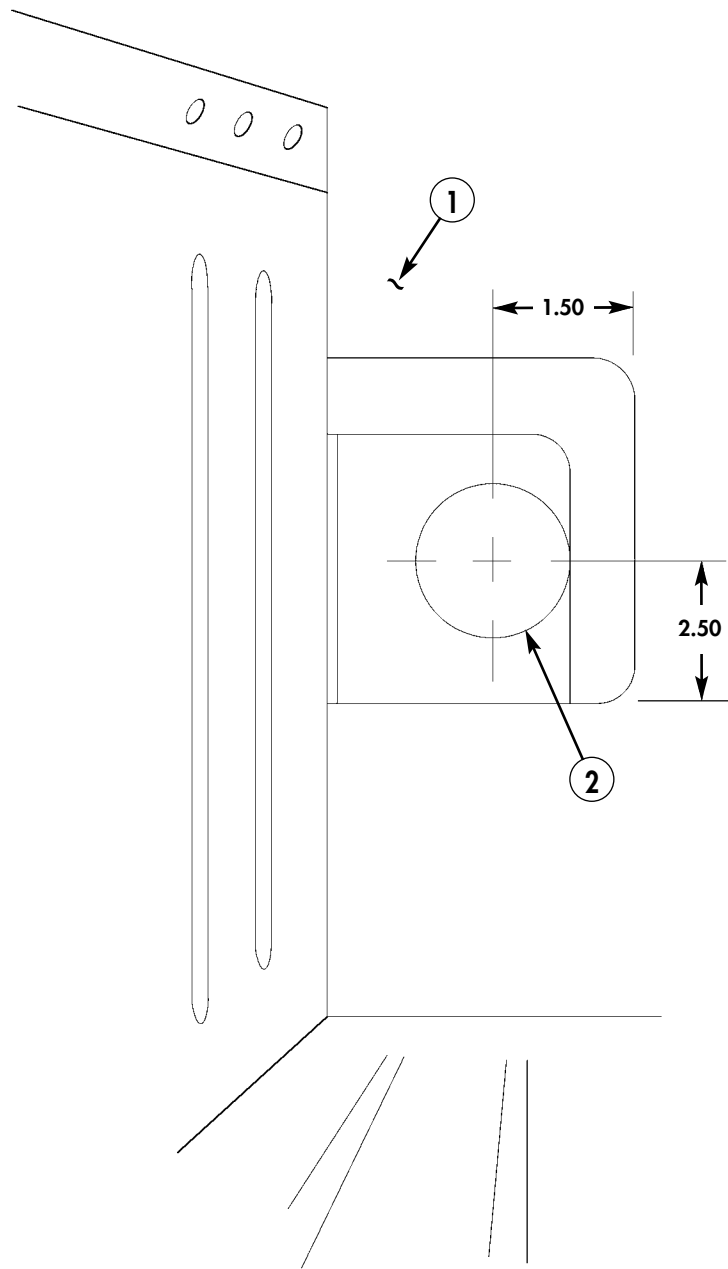

Figure 5-63.

NOTE

Capscrews are different lengths. Mark capscrews for installation.

- 10-2. Remove thirteen bolts (6), lockwashers (5), and fender washers (4) from wheelwell plate (3) and body of vehicle (1).

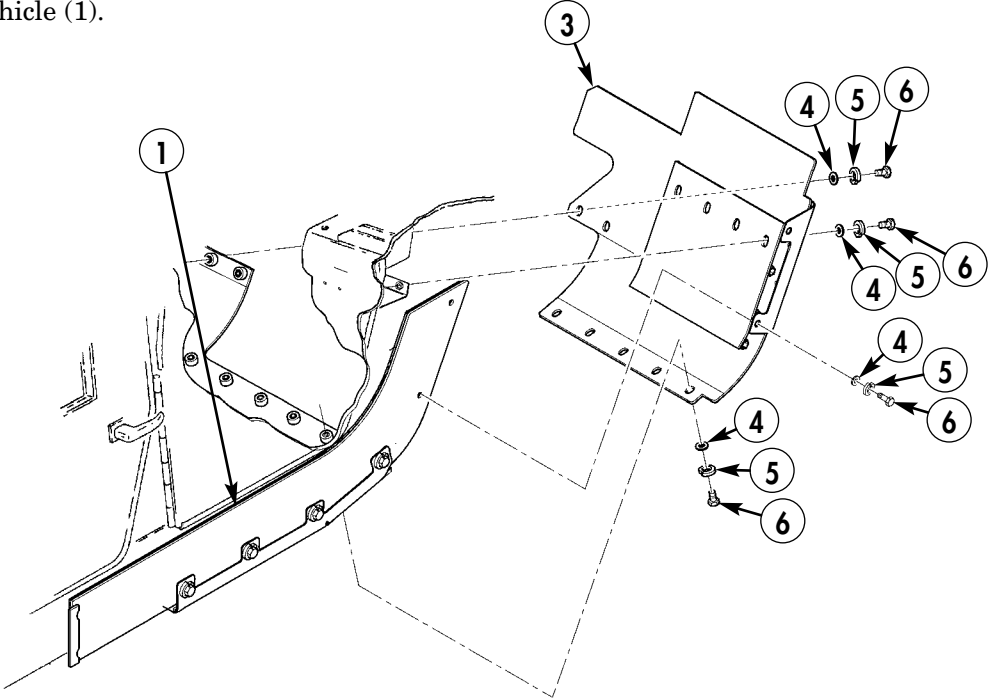

Figure 5-64.

- 10-3. Remove rear seat back armor (perimeter) (Refer to TM 9-2320-387-24).
- 10-4. Remove four capscrews (11), lockwashers (10), and washers (9) from inner armor plate (7), body of vehicle (1), and tapping plate (8). Discard lockwashers (10).

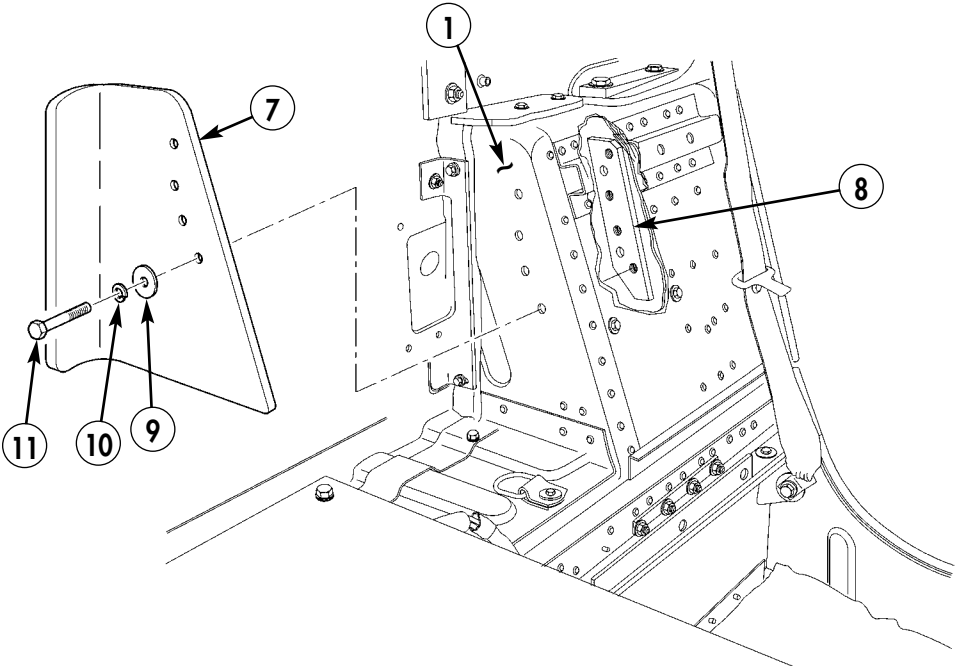

Figure 5-65.

NOTE

Antenna pedestal not shown for clarity.

- 10-5. Remove three countersunk screws (16) from interface plate (26).
- 10-6. Connect INC-EPUU cable (20) and EPLRS power cable (23) to EPLRS unit (19).
- 10-7. Route INC-EPUU cable (20) and EPLRS power cable (23) along plate (26), around URO bracket (15), down wheelhouse (27) and through hole (33) into cab of vehicle.
- 10-8. Install eight inches of spiral wrap (22) on INC-EPUU cable (20) with electrical tape (21).
- 10-9. Secure EPLRS power cable (23) and INC-EPUU cable (20) to interface plate (26) with two washers (24), clamps (25), washers (18), lockwashers (13), and capscrews (17).
- 10-10. Secure EPLRS power cable (23) and INC-EPUU cable (20) to interface plate (26) with washer (24), clamp (25), washer (18), lockwasher (13), and capscrew (28).

NOTE

Wood block is held in place with nut plate. Remove only one capscrew, washer, and lockwasher at a time to avoid nut plate falling out of position.

- 10-11. Remove capscrew (14), lockwasher (13), and washer (12) from wood block (30) and nut plate (29) on outer rear wall (31). Discard lockwasher (13).
- 10-12. Secure EPLRS power cable (23) and INC-EPUU cable (20) to wood block (30) and nut plate (29) on outer rear wall (31) with existing capscrew (14), clamp (25), lockwasher (13), and existing washer (12).
- 10-13. Remove capscrew (14), lockwasher (13), and washer (12) from wood block (30) and nut plate (29) on outer rear wall (31). Discard lockwasher (13).
- 10-14. Secure EPLRS power cable (23) and INC-EPUU cable (20) to wood block (30) and nut plate (29) on outer rear wall (31) with existing capscrew (14), clamp (25), lockwasher (13), and existing washer (12).
- 10-15. Install six inches of spiral wrap (22) on EPLRS power cable (23) and INC-EPUU cable (20) and secure with electrical tape (21).
- 10-16. Split grommet (32) and install on EPLRS power cable (23) and INC-EPUU cable (20).
- 10-17. Install grommet (32) in hole (33).

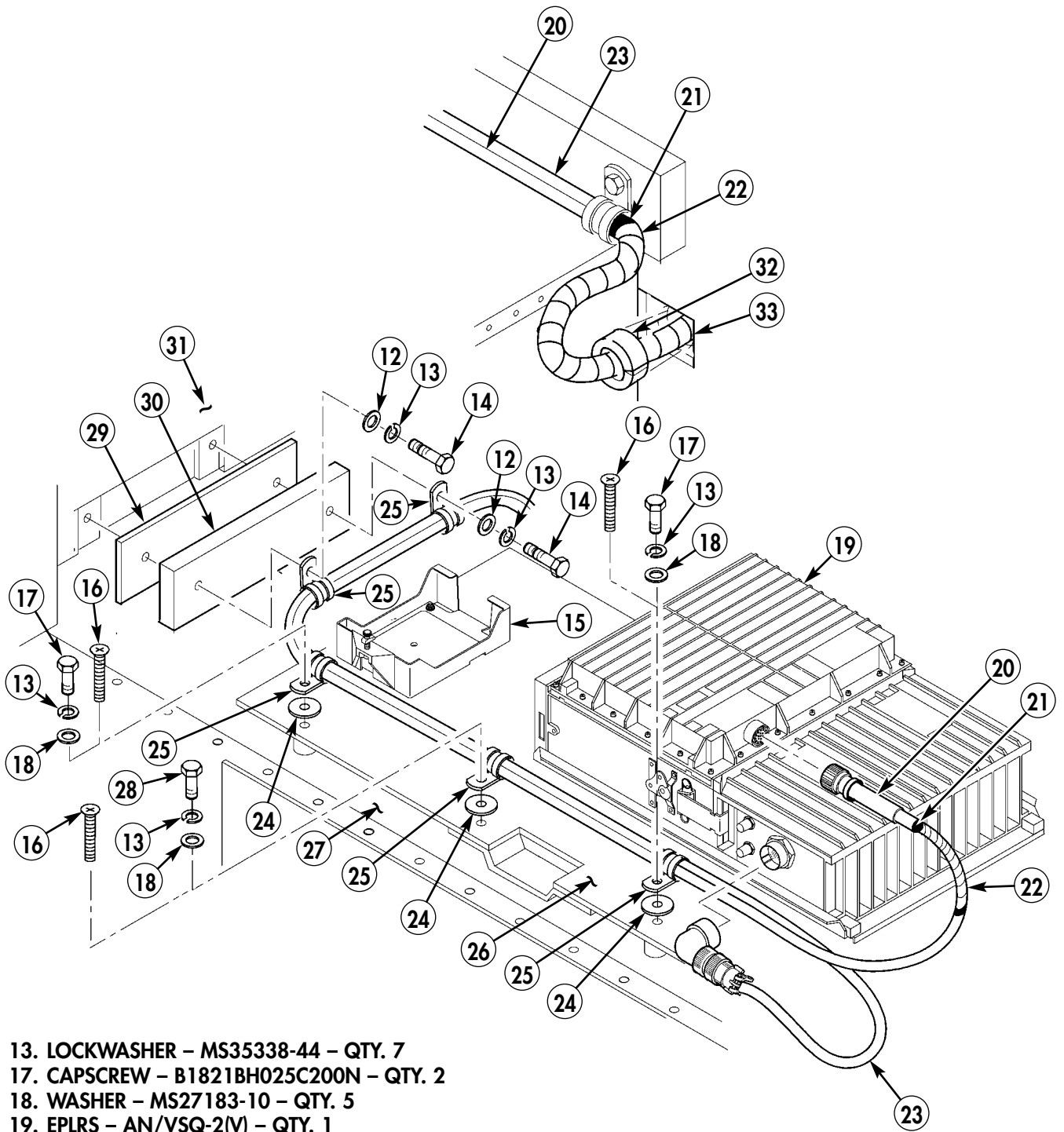

- 13. LOCKWASHER - MS35338-44 - QTY. 7
- 17. CAPSCREW - B1821BH025C200N - QTY. 2
- 18. WASHER - MS27183-10 - QTY. 5
- 19. EPLRS - AN/VSQ-2(V) - QTY. 1
- 20. INC-EPUU CABLE - A3279383-3 - QTY. 1
- 21. ELECTRICAL TAPE - HH-I-595-A-108-0 - QTY. A/R
- 22. SPIRAL WRAP - 11644992 - QTY. 14 INCHES
- 23. EPLRS POWER CABLE - A3004939-1 - QTY. 1
- 24. WASHER - MS51412-23 - QTY. 3
- 25. CLAMP, LOOP - MS21333-104 - QTY. 5
- 28. CAPSCREW - B1821BH025C125N - QTY. 1
- 32. GROMMET - MS35489-27 - QTY. 1

Figure 5-66.

- 10-18. Remove three self-tapping screws (35) and washers (36) from insulation (37) and tunnel (34).
- 10-19. Install 24 inches of spiral wrap (22) on INC-EPUU cable (20) and secure with electrical tape (21)
- 10-20. Route INC-EPUU cable (20) under tunnel insulation (37).

CAUTION

Ensure INC-EPUU cable is not pinched between tunnel insulation, tunnel, and washers when tightening self-tapping screws. Failure to comply may result in equipment damage.

- 10-21. Secure tunnel insulation (37) to tunnel (34) with three existing self-tapping screws (35) and washers (36).

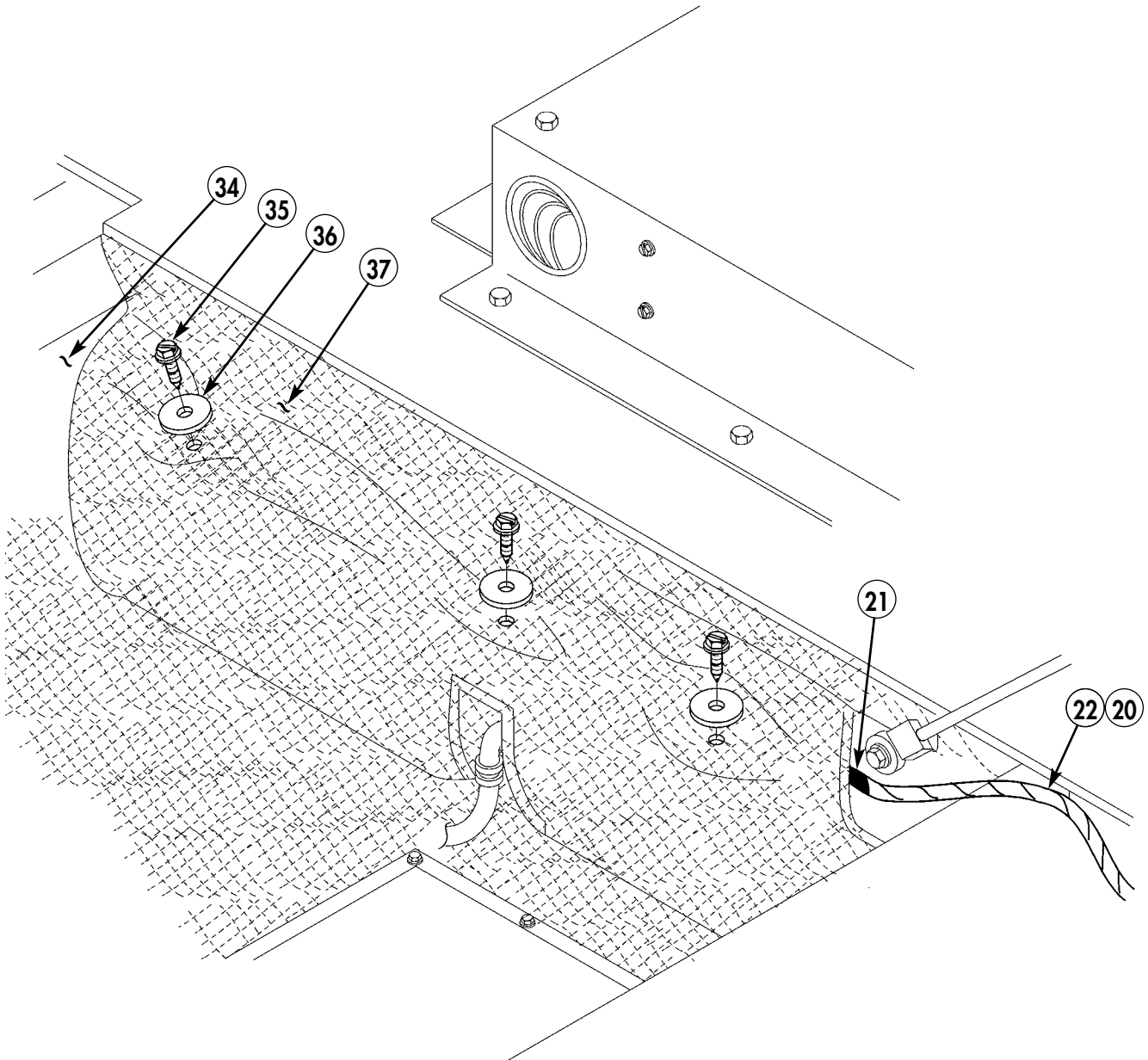

- 21. ELECTRICAL TAPE – HH-I-595-A-108-0 – QTY. A/R
- 22. SPIRAL WRAP – 11644992 – QTY. 24 INCHES

Figure 5-67.

- 10-22. Install inner armor plate (7) to body of vehicle (1) with four existing capscrews (11), lockwashers (10), existing washers (9), and tapping plate (8).
- 10-23. Install seat back armor (perimeter). (Refer to TM 9-2320-387-24.)

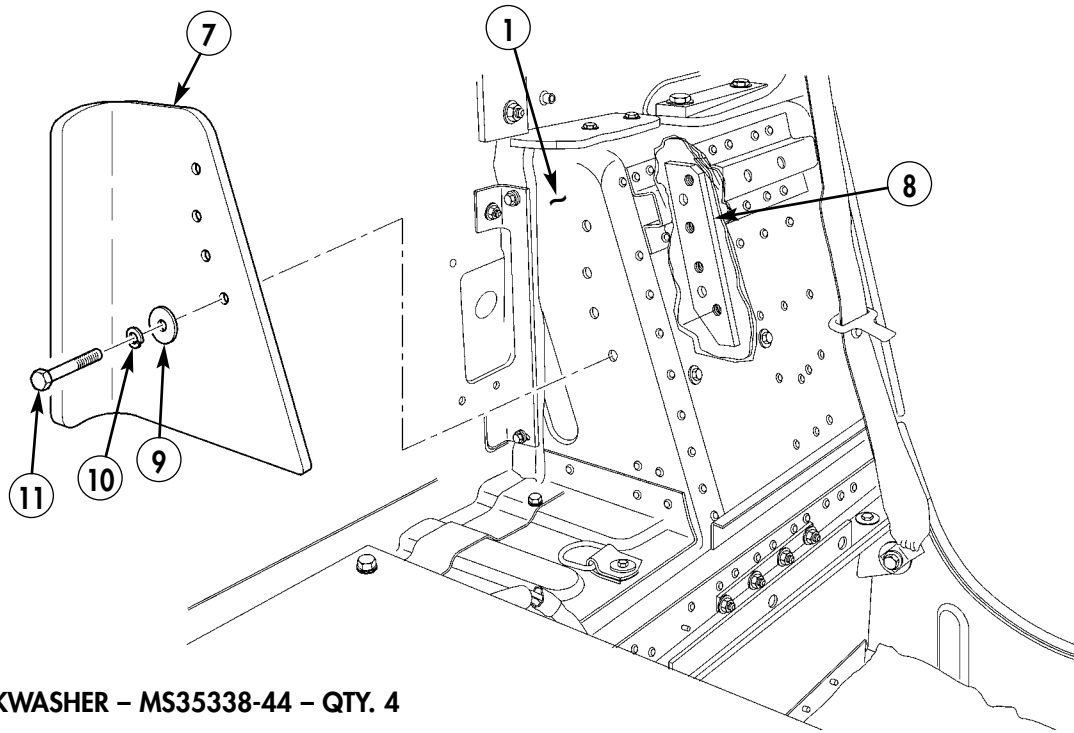

10. LOCKWASHER – MS35338-44 – QTY. 4

Figure 5-68.

- 10-24. Install wheelwell plate (3) on body of vehicle (1) with thirteen capscrews (6), lockwashers (5), and fender washers (4).

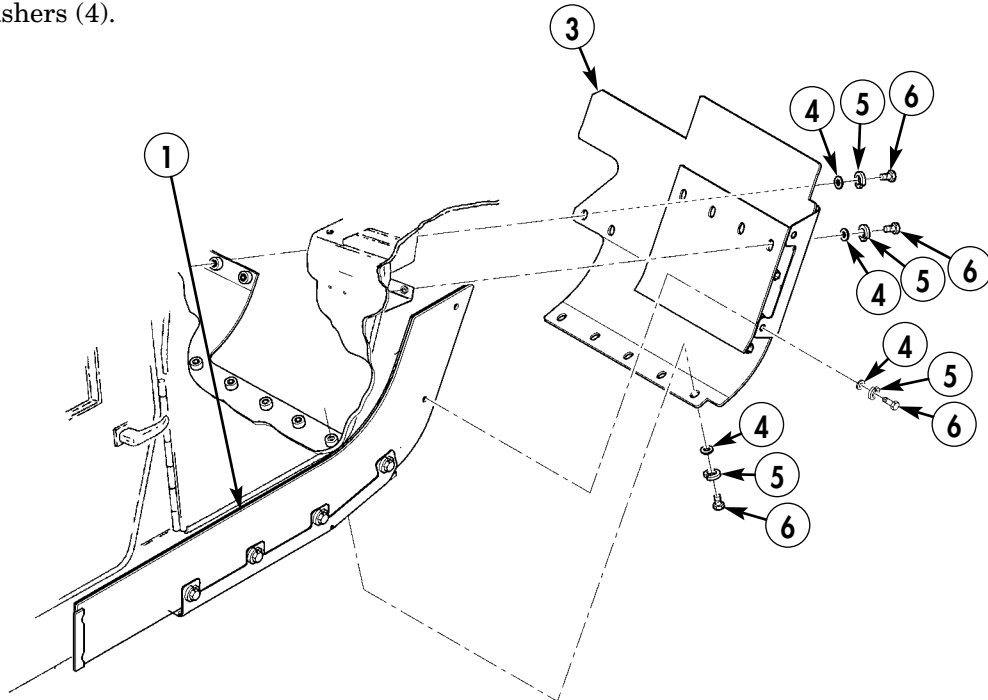

5. LOCKWASHER – MS35338-46 – QTY. 11

Figure 5-69.

NOTE

Screws are different lengths. Mark screws for installation.

- 10-25.** Remove six screws (38) from wood insulation (39) and lift front of insulation from tunnel floor (40).

CAUTION

Ensure INC-EPUU cable lays flat against floor. Cable should be off insulation and between floor ribs. Failure to comply may result in equipment damage.

- 10-26.** Route INC-EPUU cable (20) along tunnel floor (40).

- 10-27.** Install wood insulation (39) on tunnel floor (40) with six existing screws (38).

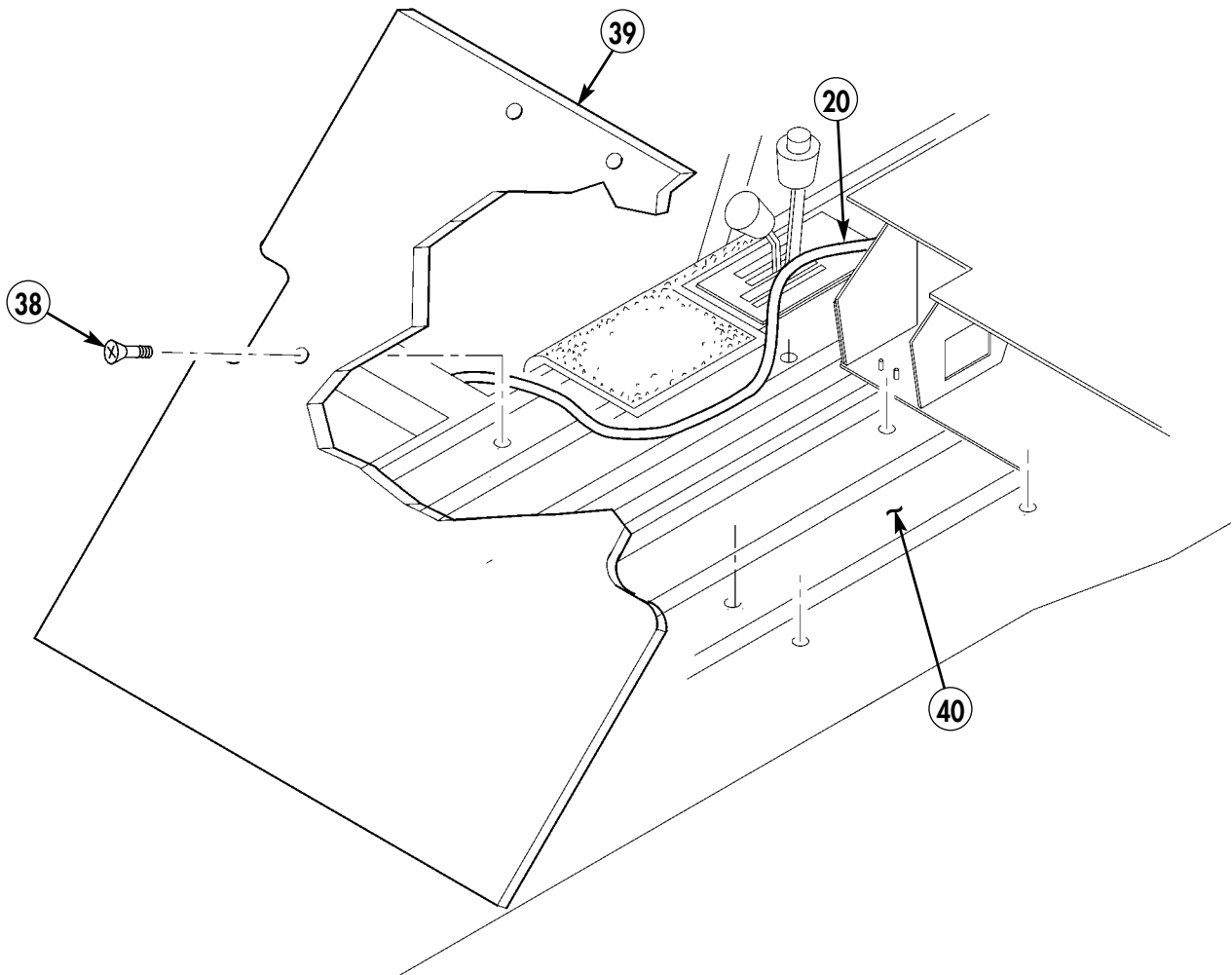
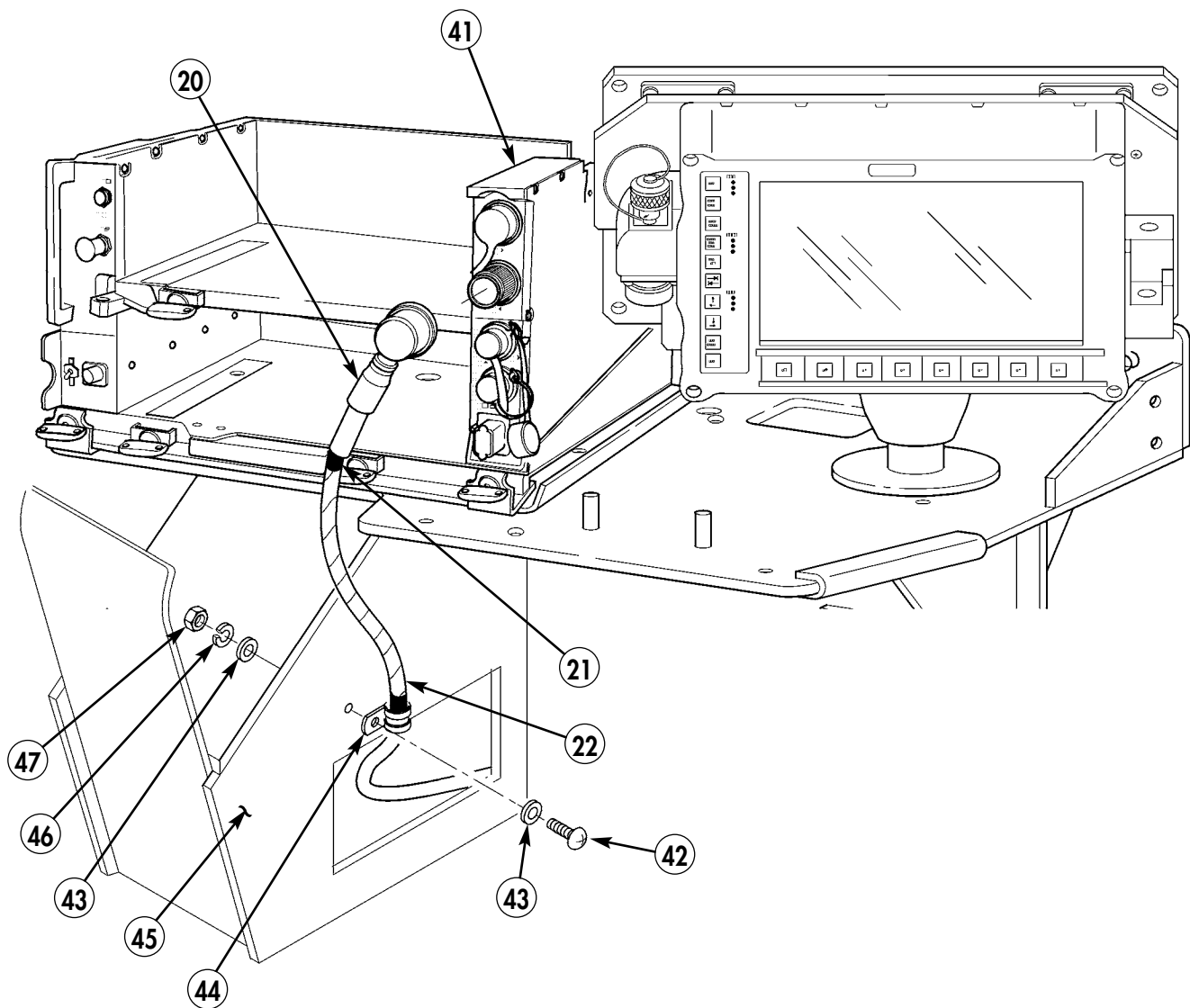

Figure 5-70.

- 10-28.** Route INC-EPUU cable (20) through integrated rack (45) to vehicular amplifier adapter (VAA) (41).
- 10-29.** Secure INC-EPUU cable (20) to integrated rack (45) with clamp (44), capscrew (42), two washers (43), lockwasher (46), and nut (47).
- 10-30.** Install six inches of spiral wrap (22) on INC-EPUU cable (20) and secure with electrical tape (21).



- 21.** ELECTRICAL TAPE – HH-I-595-A-108-0 – QTY. A/R
22. SPIRAL WRAP – 11644992 – QTY. 6 INCHES
42. CAPSCREW – MS35206-266 – QTY. 1
43. WASHER – 9416128 – QTY. 2
44. CLAMP, LOOP – MS21333-72 – QTY. 1
46. LOCKWASHER – MS35338-43 – QTY. 1
47. NUT – 120361 – QTY. 1

Figure 5-71.

10-31. Route power cable (23) along inner rear wall (50) and secure to existing studs (49) with three washers (18), loop clamps (44), and locknuts (48).

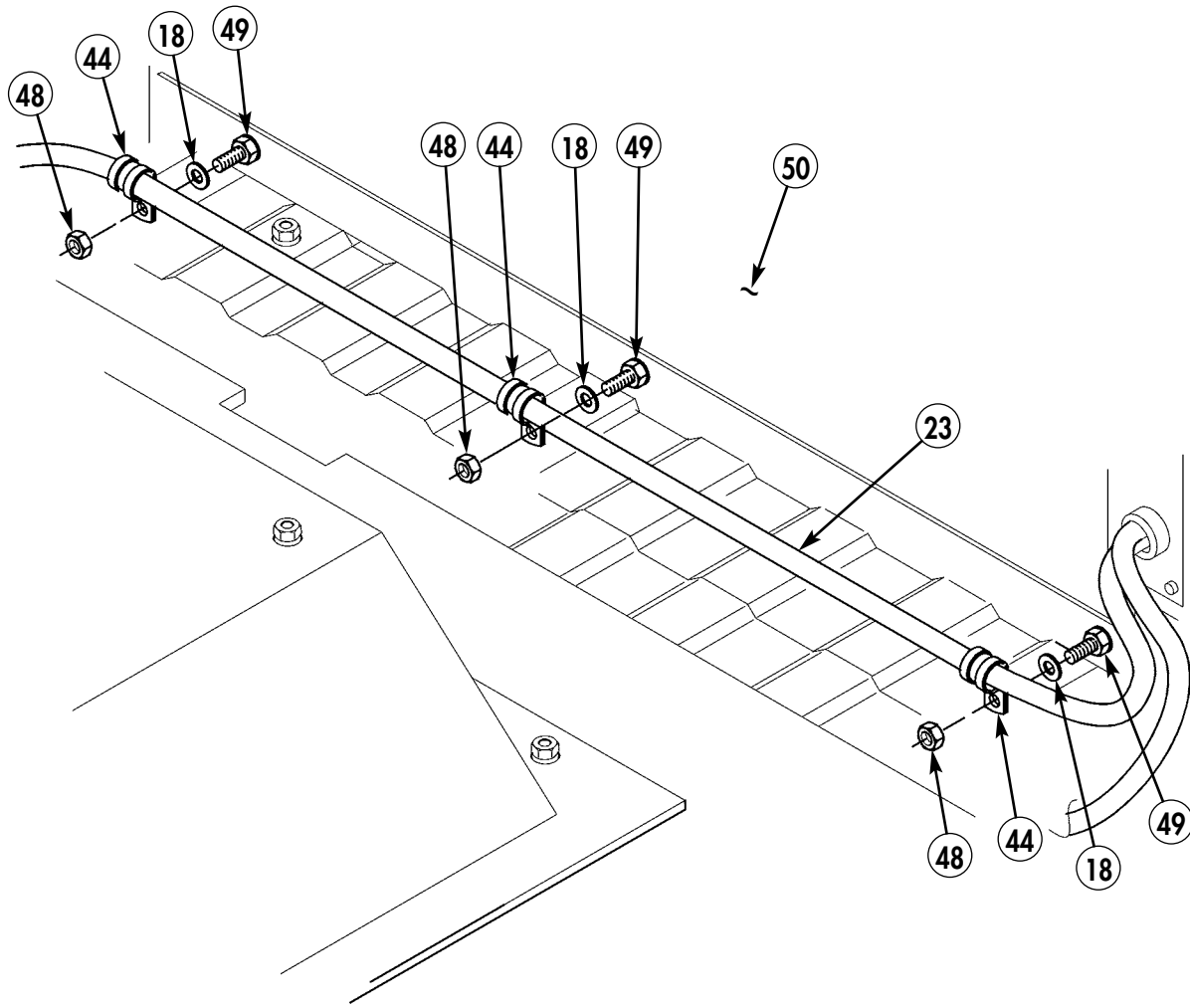

- 18. WASHER – MS27183-10 – QTY. 3
- 44. CLAMP, LOOP – MS21333-101 – QTY. 3
- 48. LOCKNUT – M45913/4-4CG8Z – QTY. 3

Figure 5-72.

- 10-32. Secure EPLRS power cable (23) to wood insulation (53) with clamp (52), self-tapping screw (51), and lockwasher (46).
- 10-33. Install six inches of spiral wrap (22) on EPLRS power cable (23) and secure with electrical tape (21).

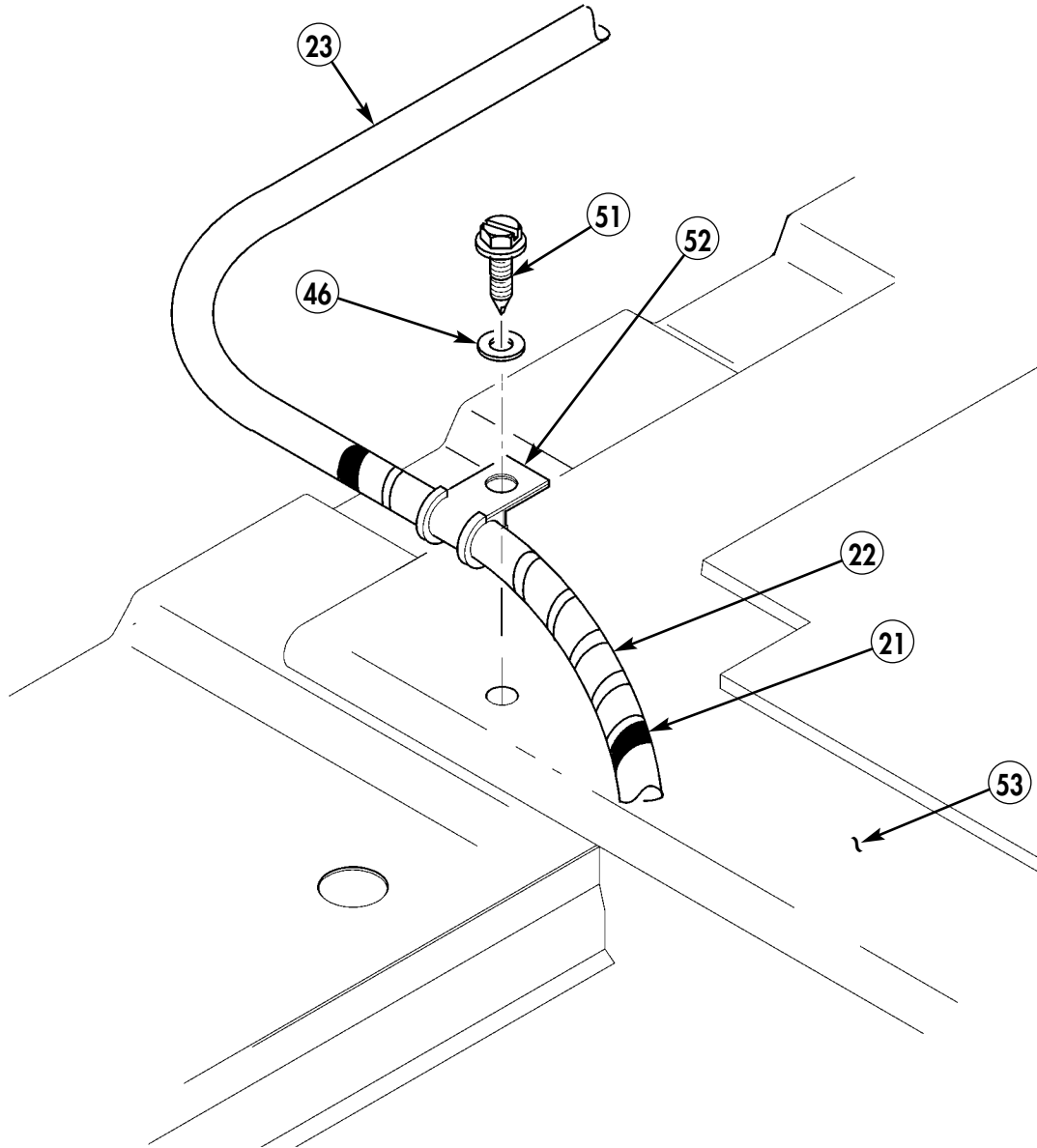

- 21. ELECTRICAL TAPE – HH-I-595-A-108-0 – QTY. A/R
- 22. SPIRAL WRAP – 11644992 – QTY. 6 INCHES
- 46. WASHER, LOCK – MS35338-43 – QTY. 1
- 51. SELF-TAPPING SCREW – 12342499-2 – QTY. 1
- 52. CLAMP, LOOP – MS21333-72 – QTY. 1

Figure 5-73.

- 10-34. Disconnect rear evaporator electrical harness (60) from evaporator (54).
- 10-35. Remove three self-tapping screws (55), clamps (56), rear evaporator electrical harness (60), and three washers (57) from insulation (58) and tunnel (59).
- 10-36. Route EPLRS power cable (23) under insulation (58) to right B-beam.

CAUTION

Ensure EPLRS power cable is not pinched between tunnel insulation, tunnel, clamps, and washers when tightening self-tapping screws. Failure to comply may result in equipment damage.

- 10-37. Install insulation (58) on tunnel (59) with three existing self-tapping screws (55), clamps (56), washers (57), and rear evaporator electrical harness (60).
- 10-38. Connect rear evaporator electrical harness (60) to evaporator (54).

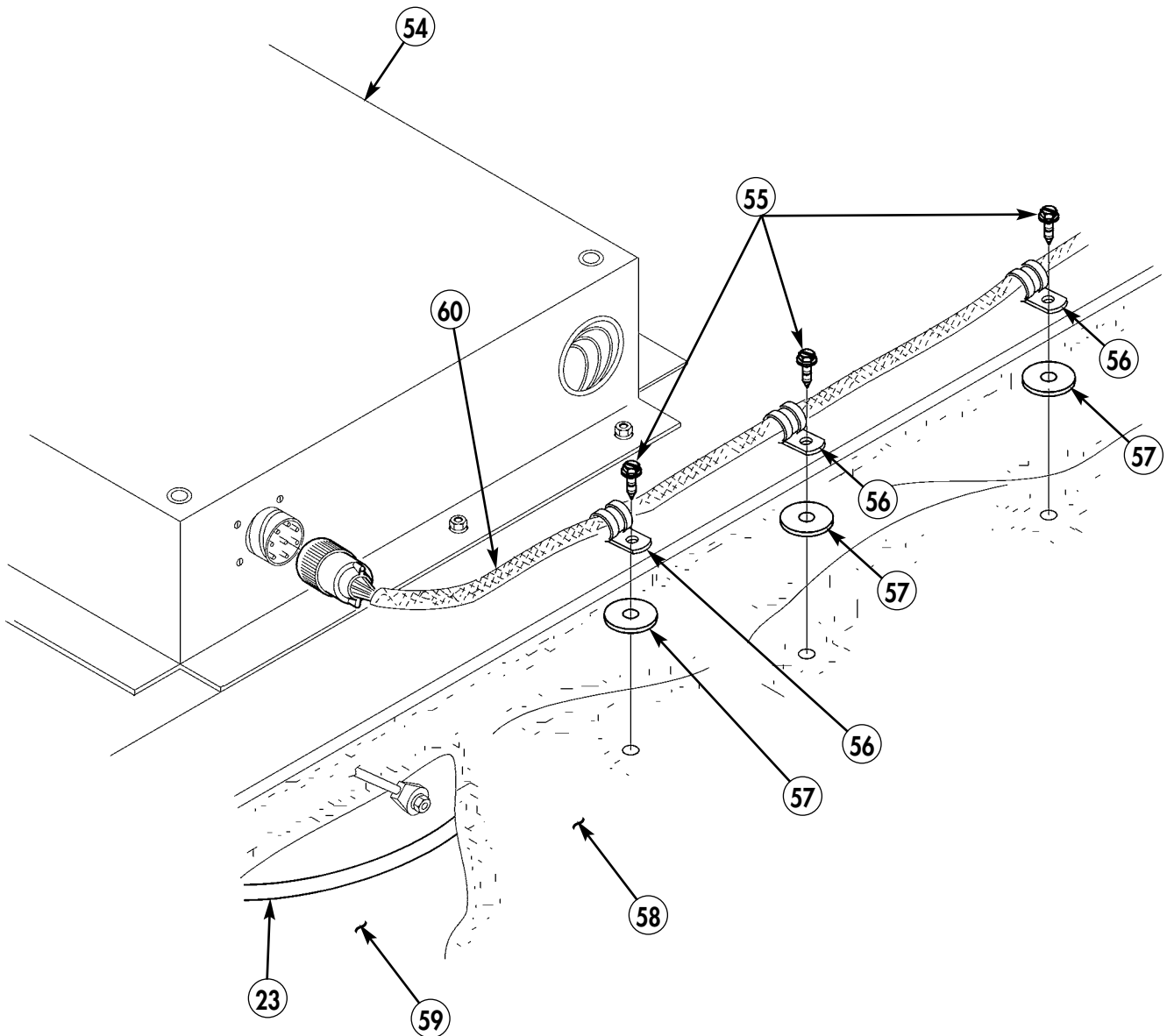

Figure 5-74.

NOTE

Vehicles with serial number SN248732 and above will not have 200 amp power connector.

- 10-39. Remove three capscrews (61), lockwashers (62), and washers (63) from right-side cab enclosure panel (64) and B-beam (65). Discard lockwashers (62).
- 10-40. Remove two capscrews (61), lockwashers (62), and washers (67), from right-side cab enclosure panel (64) and rear of battery box (66). Discard lockwashers (62).

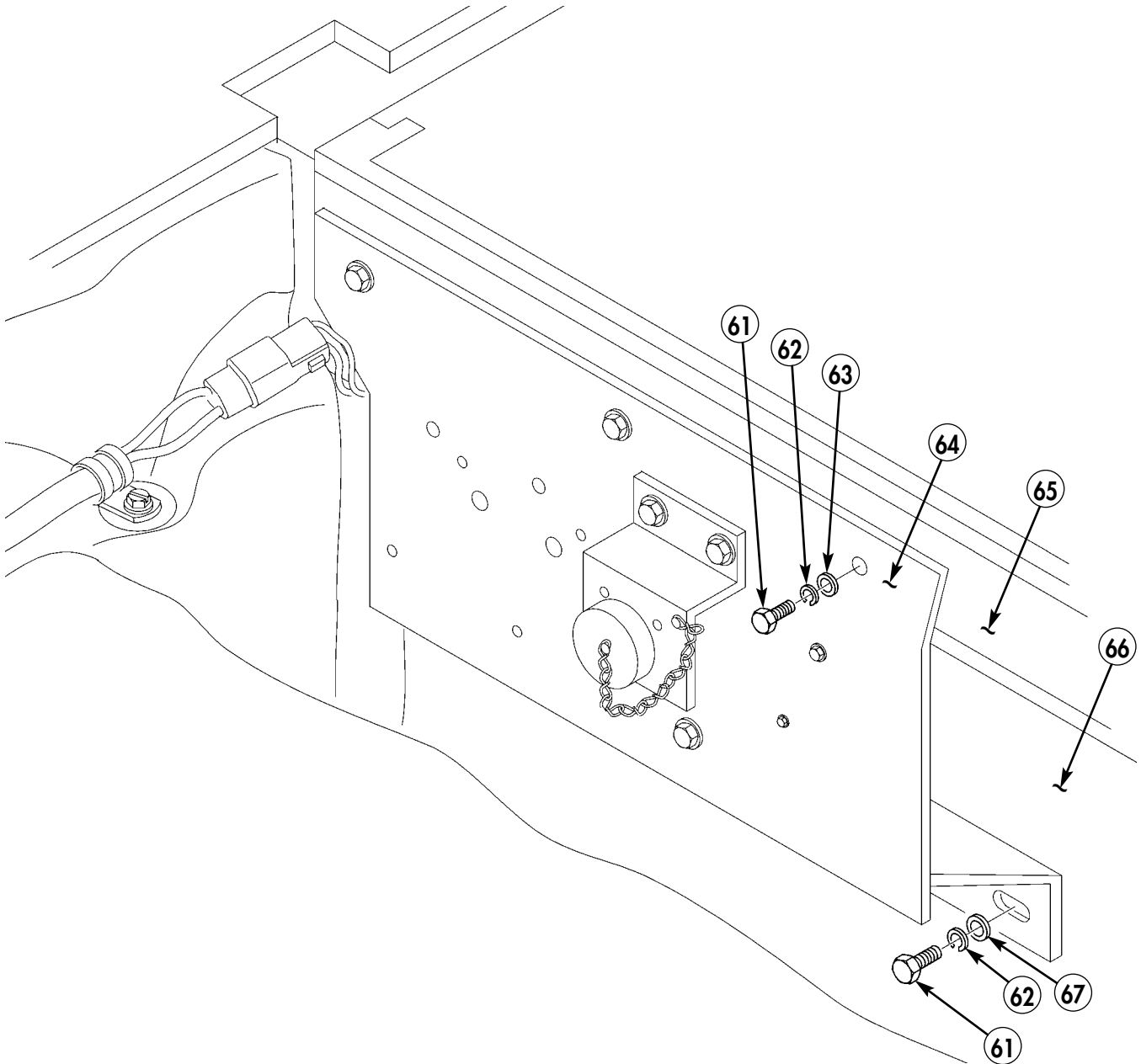
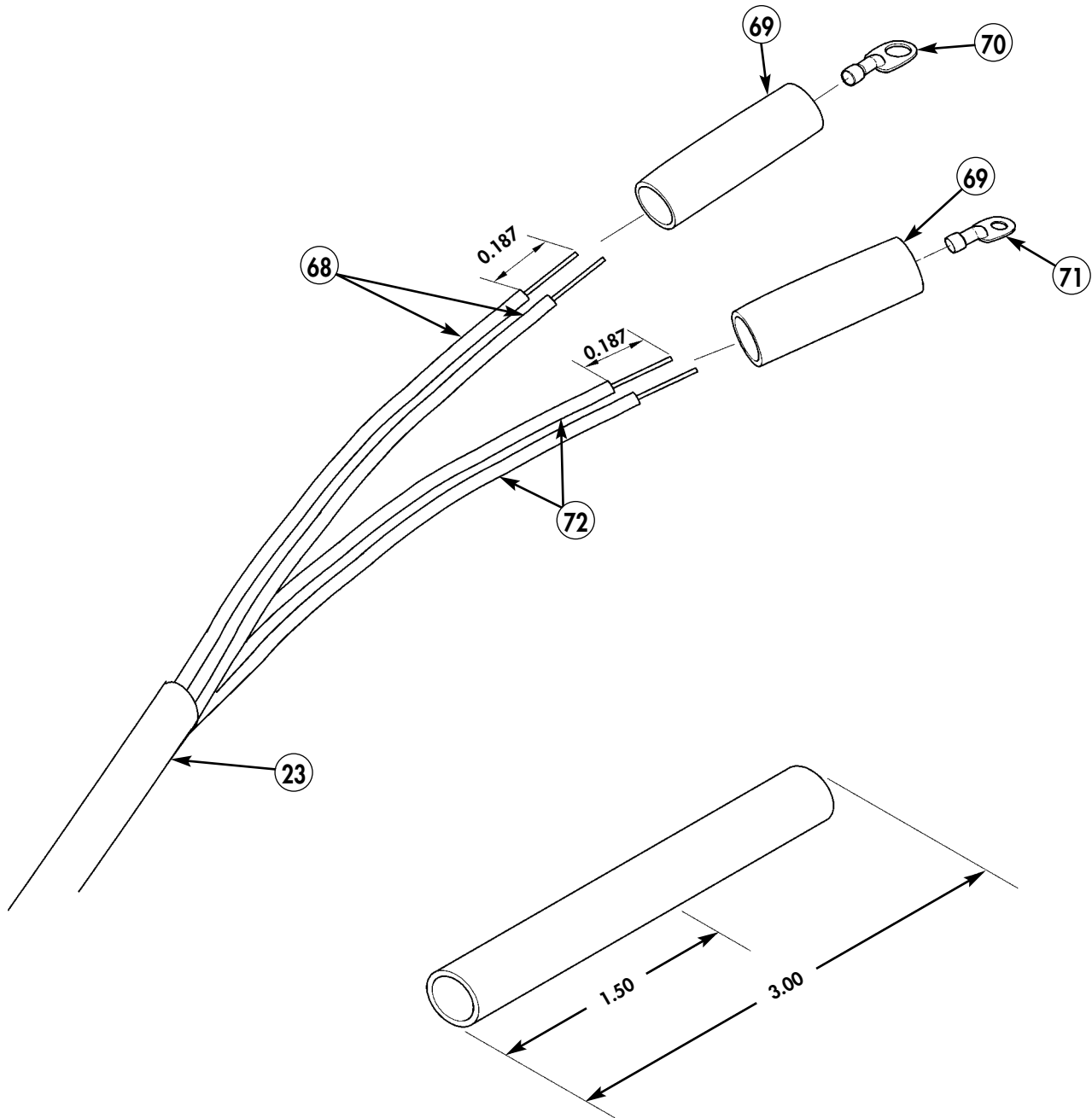

Figure 5-75.

- 10-41. Remove 0.187-inch of insulation from negative (72) and positive (68) wires on power cable (23).
- 10-42. Attach shrink tubing (69) and terminal lugs (71) and (70) to power cable negative lead (72) and power cable positive lead (68). (Refer to TM 9-2320-387-24 for terminal connector repair.)



- 69. SHRINK TUBING - MS23054/4-103-0 - QTY. 3 INCHES.
- 70. TERMINAL LUG - 7728780 - QTY. 1
- 71. TERMINAL LUG - 7728777 - QTY. 1

Figure 5-76.

- 10-43. Remove terminal board cover (73) from positive terminal board (79).
- 10-44. Remove locknut (75) from positive stud (74) on positive terminal board (79). Discard locknut (75).
- 10-45. Remove locknut (76) from negative stud (77) on negative terminal board (78). Discard locknut (76).
- 10-46. Connect positive terminal (70) to positive stud (74) on positive terminal board (79) with locknut (75).
- 10-47. Connect negative terminal (71) to negative stud (77) on negative terminal board (78) with locknut (76).
- 10-48. Install terminal board cover (73) on positive terminal board (79).

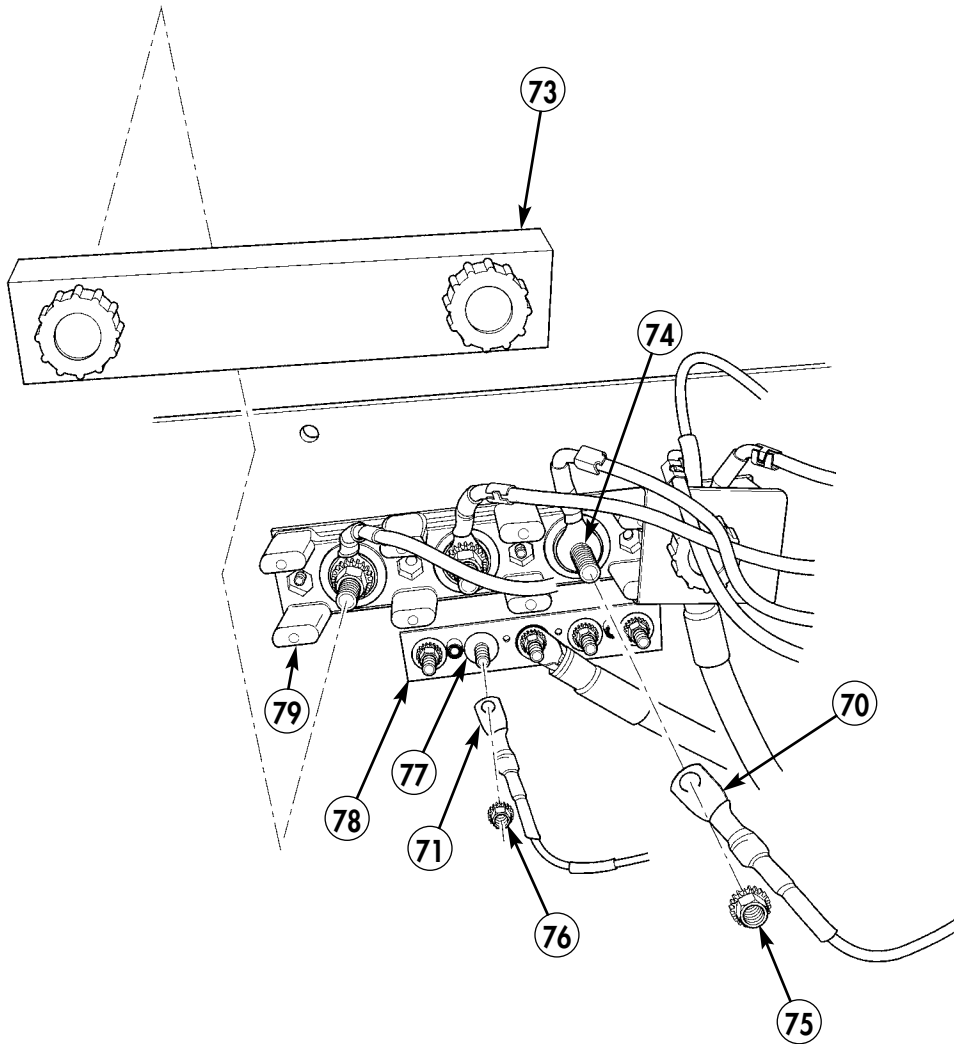

- 75. LOCKNUT - 271175 - QTY. 1
- 76. LOCKNUT - 271169 - QTY. 1

Figure 5-77.

- 10-49. Install right side cab enclosure panel (62) to rear of battery box (64) with two existing capscrews (67), lockwashers (66), and existing washers (65).

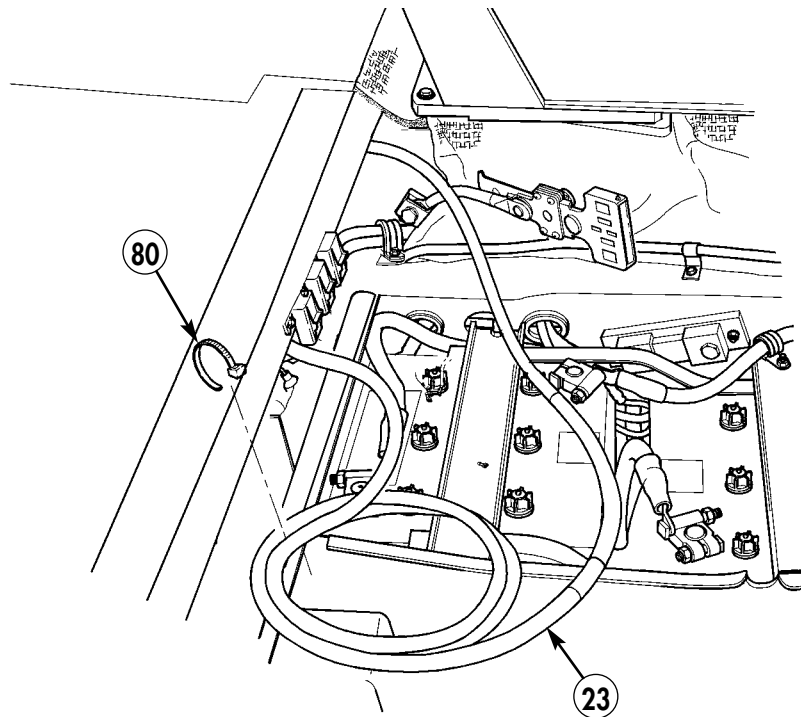

82. TIE-DOWN STRAP – MS3367-1-0 – QTY. 1

Figure 5-78.

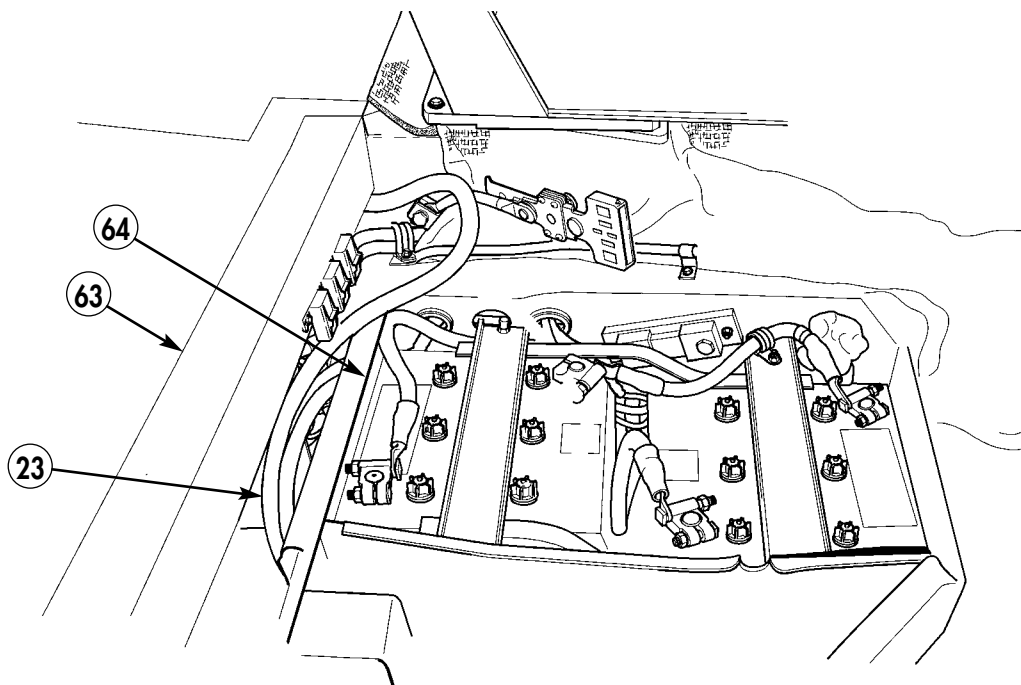
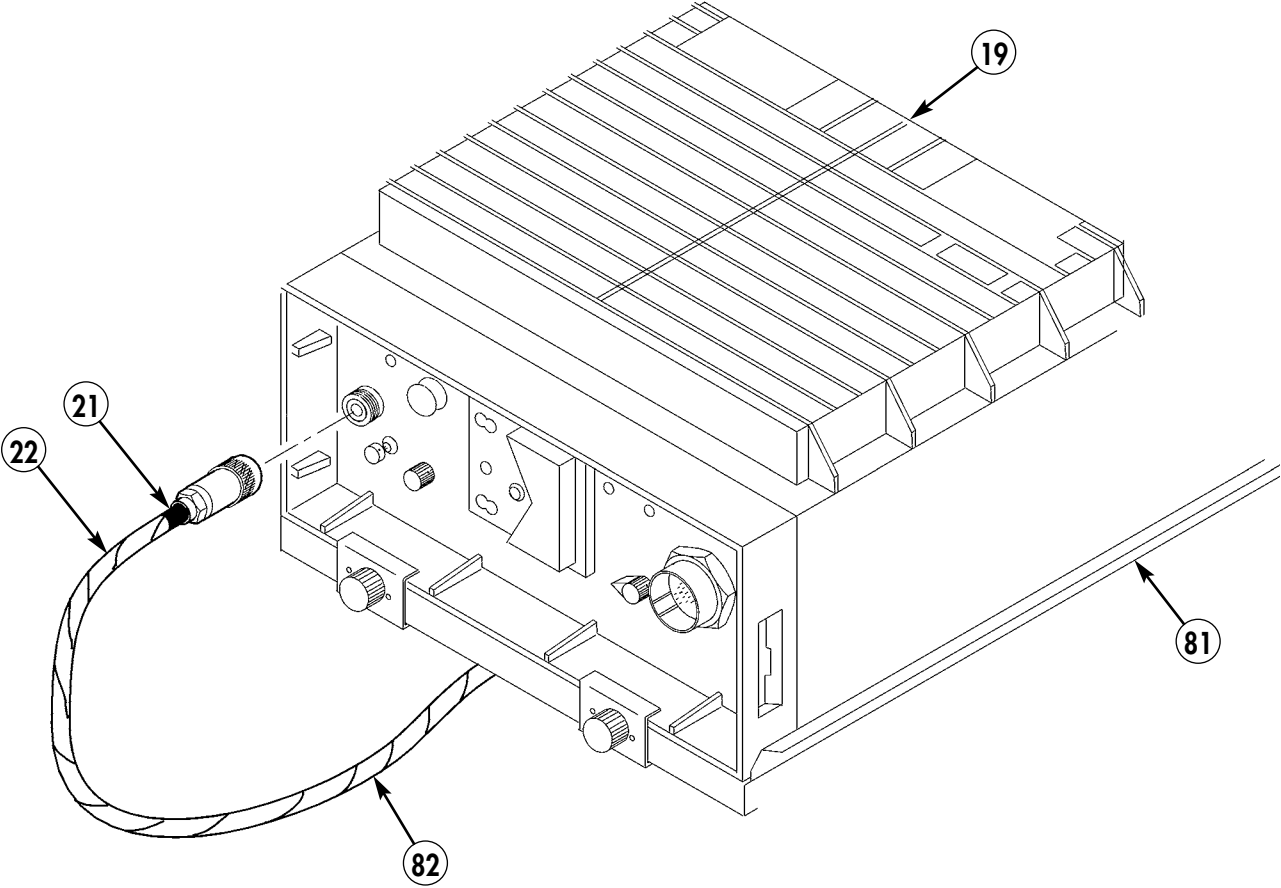

Figure 5-79.

10-50. Secure right side cab enclosure panel (62) to B-beam (63) with two existing self-tapping screws (61).



- 21. ELECTRICAL TAPE – HH-I-595-A-108-0 – QTY. A/R
- 22. SPIRAL WRAP – 11644992 – QTY. 6 INCHES
- 82. EPLRS ANTENNA CABLE – SM-C-911480 – QTY. 1

Figure 5-80.

10-54. Secure EPLRS antenna cable (82) to antenna base (88) with two existing screws (83), loop clamps (87), four existing washers (84), two existing lockwashers (85), and nuts (86).

10-55. Connect antenna cable (82) to antenna (89).

10-56. Tighten screws and nuts on all clamps.

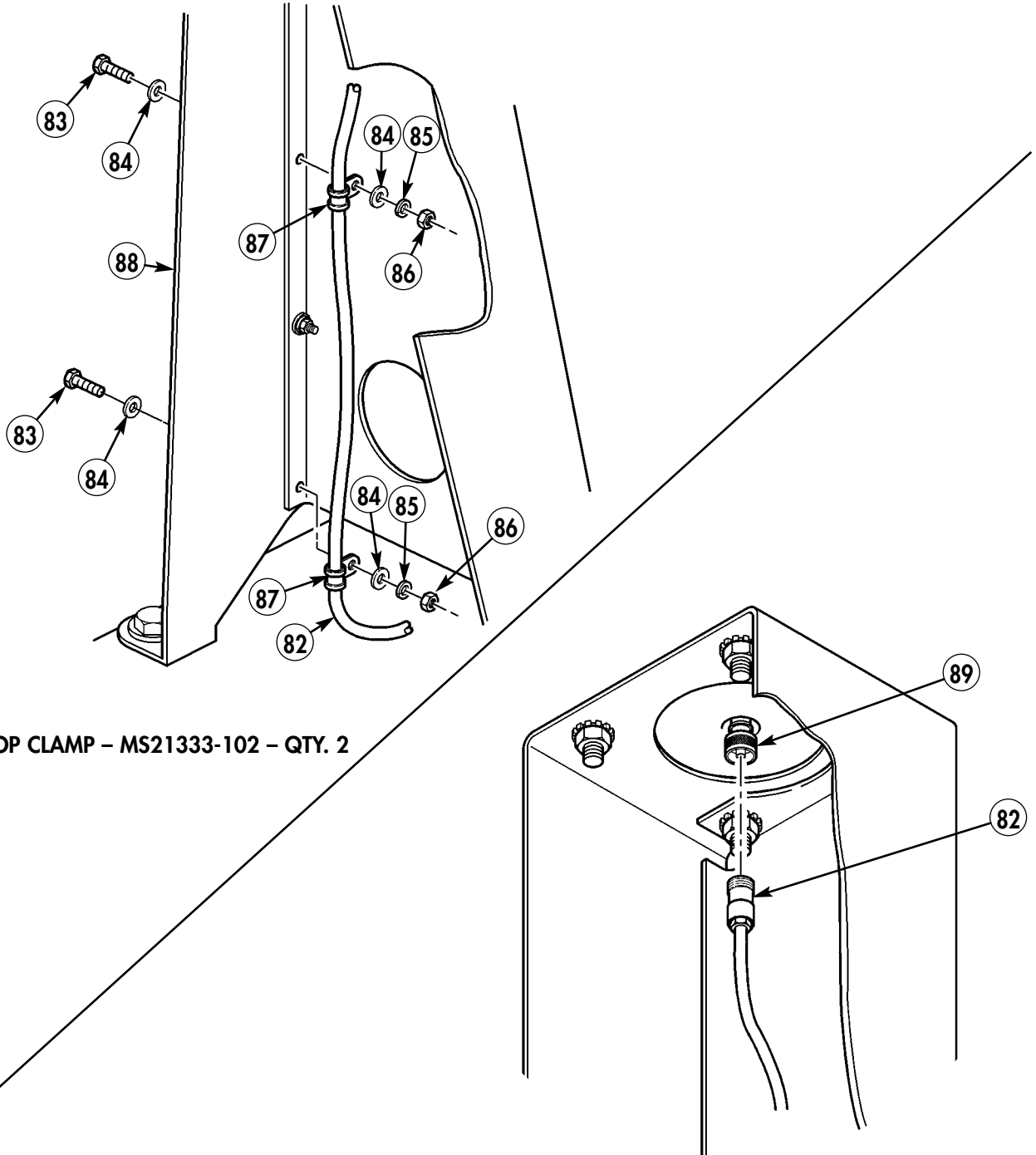

87. LOOP CLAMP – MS21333-102 – QTY. 2

Figure 5-81.

10-57. Attach URO cable (90) to EPLRS unit (19).

10-58. Route URO cable (90) to URO mount (91).

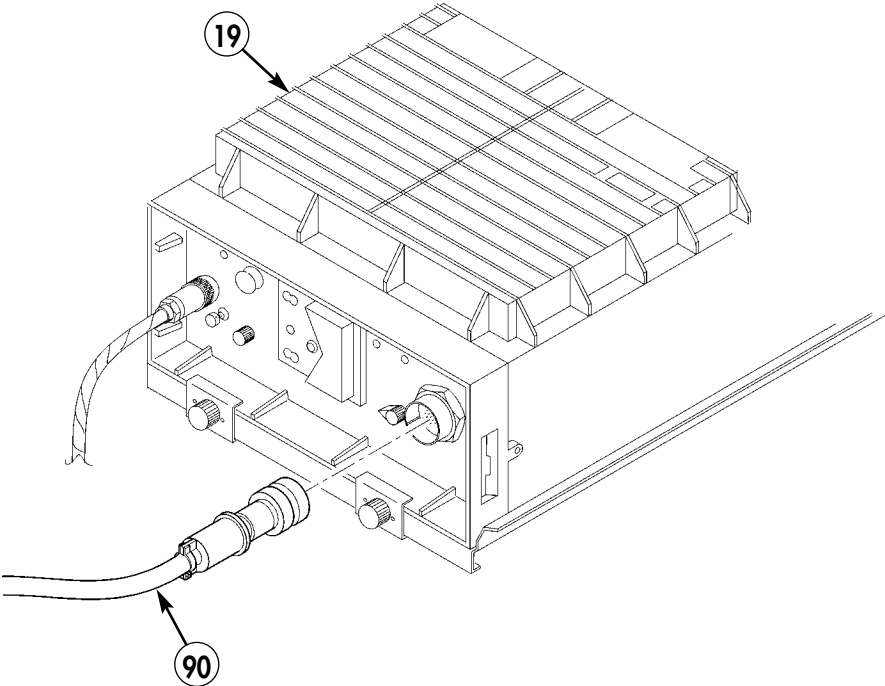

90. URO CABLE – A3109227 – QTY. 1

Figure 5-82.

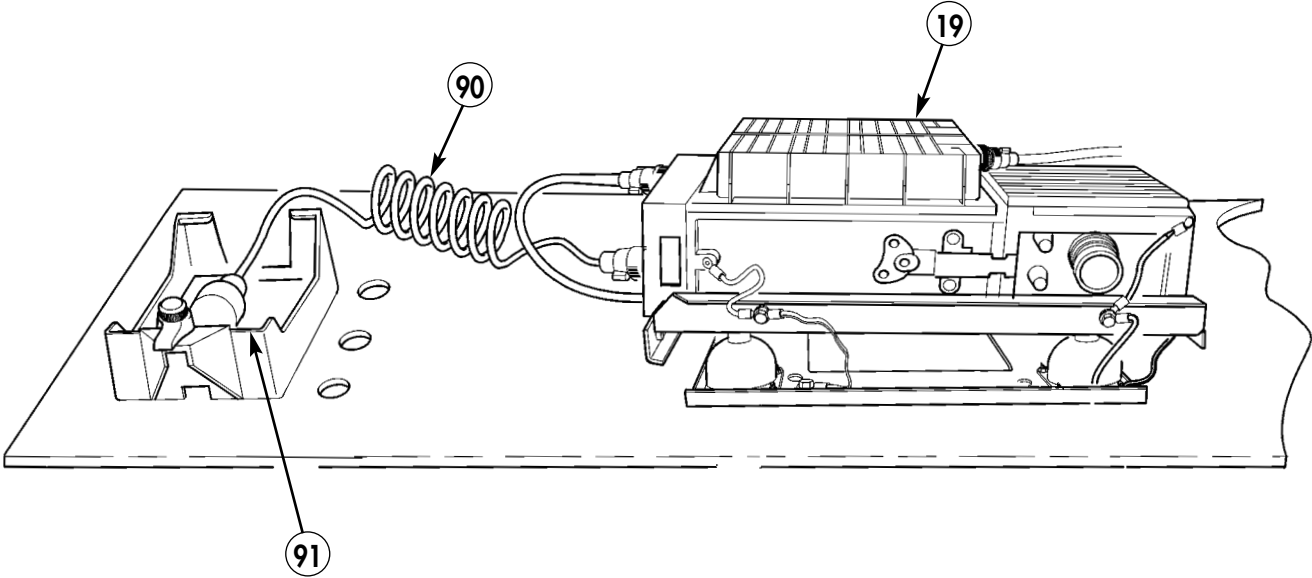

Figure 5-83.

Section XI. SINGARS ANTENNA INSTALLATION

NOTE

This procedure applies to vehicles without existing antennas, and to either left or right side of vehicle.

- 11-1. Using antenna mounting bracket (3) as template, locate and mark hole position (2) in rear wall (4).
- 11-2. Locate and mark hole positions (1) in rear wall (4).
- 11-3. Remove antenna mounting bracket (3) from rear wall (4).
- 11-4. Drill 1.375-in. diameter hole (2) in rear wall (4).
- 11-5. Drill three 0.343-in. diameter holes (1) in rear wall (4).
- 11-6. Remove paint from vicinity of three holes (1) and three holes in antenna mounting bracket (3).
- 11-7. Apply antiseize compound to vicinity of three holes (1) and rear of antenna mounting bracket (3).

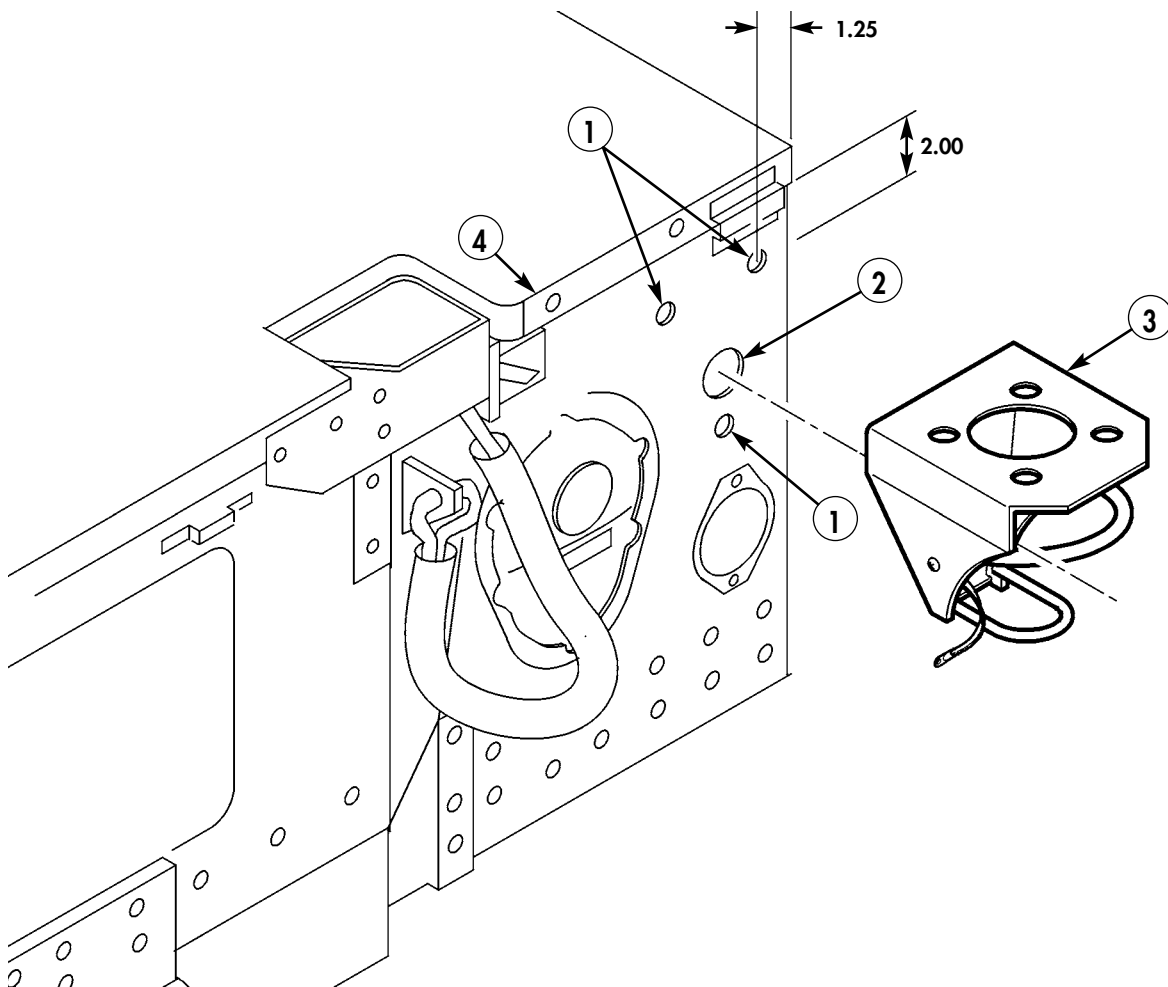

3. ANTENNA MOUNTING BRACKET - A3014546-1 - QTY. 2

Figure 5-84.

- 11-8. Install grommet (13) in hole (2) of rear wall (4).
- 11-9. Position antenna base (14) and gasket (7) on antenna mounting bracket (3) and route existing ground strap (9) through antenna bracket (3).
- 11-10. Install antenna base (14) on antenna mounting bracket (3) with four capscrews (5), eight lockwashers (6), and four nuts (8).
- 11-11. Install antenna mounting bracket (3) on rear wall (4) with two capscrews (10), lockwashers (12), washers (15), and nuts (16).
- 11-12. Remove old terminal lug, and install new terminal lug (11) on ground strap (9). Install ground strap (9) and antenna mounting bracket (3) on rear wall (4) with capscrew (10), lockwasher (12), washer (15), and nut (16).

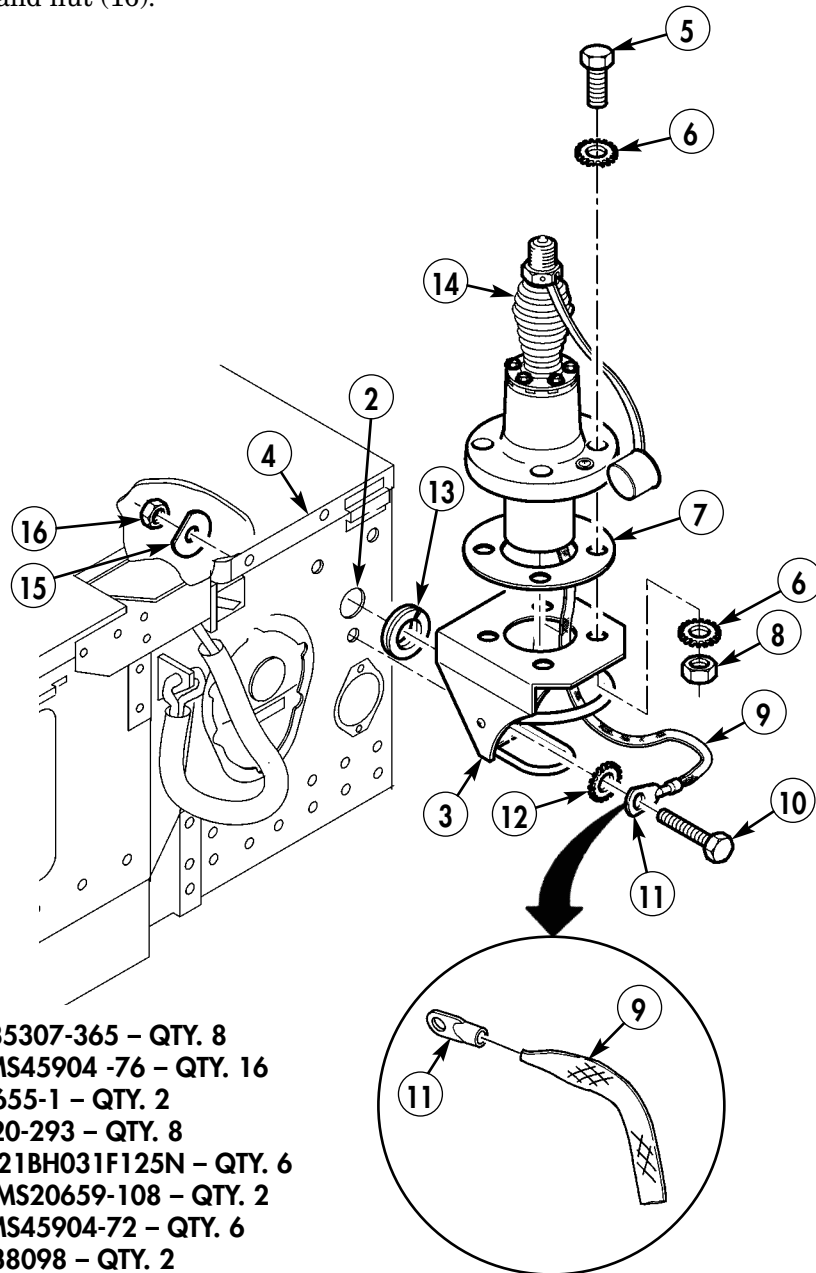

5. CAPSCREW – MS35307-365 – QTY. 8
 6. LOCKWASHER – MS45904 -76 – QTY. 16
 7. GASKET – A3013655-1 – QTY. 2
 8. NUT – 13218E0320-293 – QTY. 8
 10. CAPSCREW – B1821BH031F125N – QTY. 6
 11. TERMINAL LUG – MS20659-108 – QTY. 2
 12. LOCKWASHER – MS45904-72 – QTY. 6
 13. GROMMET – 12338098 – QTY. 2
 14. ANTENNA BASE – A3017899-2 – QTY. 2
 15. WASHER – 12338095 – QTY. 6
 16. NUT – 9418892 – QTY. 6

Figure 5-85.

- 11-13. Attach upper antenna element (17) to lower antenna element (19).
- 11-14. Attach antenna assembly to antenna base (14).
- 11-15. Attach fiber rope assembly (18) to upper antenna element (17).
- 11-16. Secure lower antenna element (19) to antenna base (14) with lock wire (20).
- 11-17. Repeat steps 11-1 through 11-16 for opposite side of vehicle, if applicable.

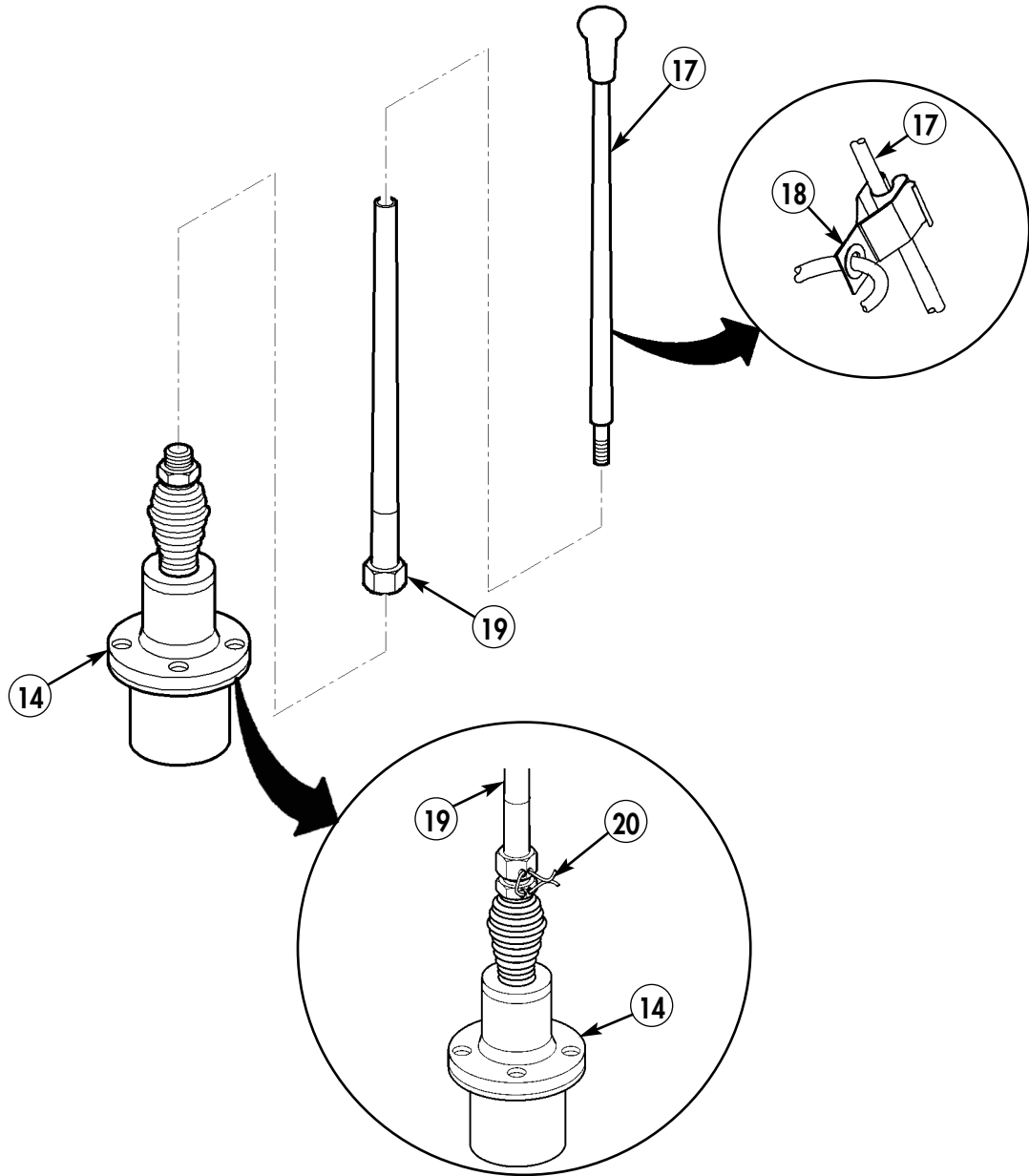

- 17. UPPER ANTENNA ELEMENT – A3017901-2 – QTY. 2
- 19. LOWER ANTENNA ELEMENT – A3018230-1 – QTY. 2
- 20. LOCK WIRE – MS20995C32 – QTY. A/R

Figure 5-86.

Section XII. SINGARS CABLES INSTALLATION

NOTE

Tag capscrews, lockwashers, and washers for installation.

- 12-1.** Remove thirteen bolts (5), lockwashers (4), fender washers (3), and wheelwell plate (1) from body of vehicle (2).

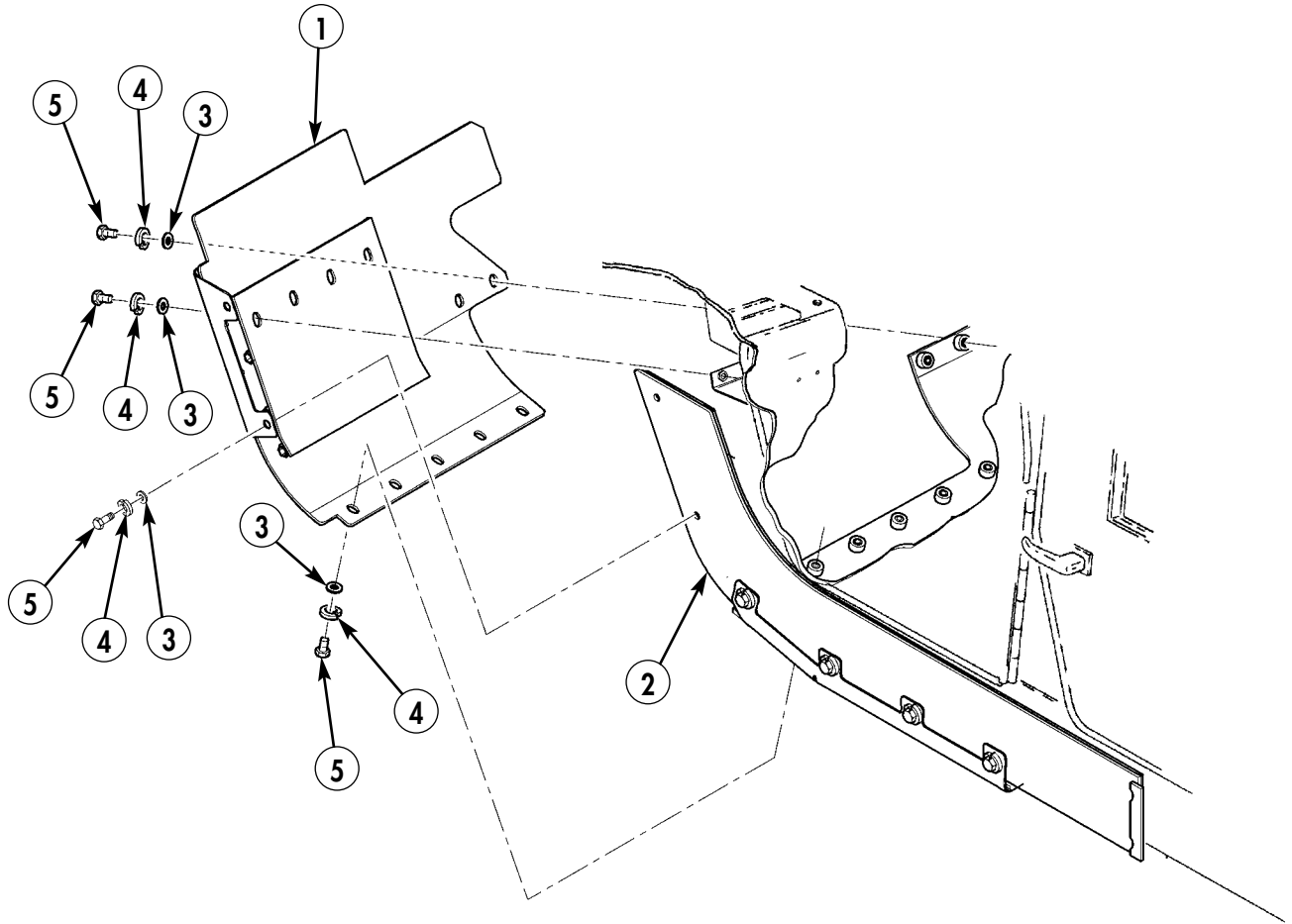

Figure 5-87.

- 12-2. Route antenna cable (22) through vehicle body (2) to antenna base (24).
- 12-3. Attach antenna cable (22) to antenna base (24).
- 12-4. Remove locknut (12) from screw (15) on lower mounting position of reflector (14). Discard locknut (12).
- 12-5. Install clamp (13) on antenna cable (22) and secure to existing screw (15) with locknut (12).
- 12-6. Route antenna cable (22) along taillight wiring harness with two existing loop clamps (23) and (20), and secure with self-tapping screws (19).

NOTE

Left side antenna cable may not apply.

- 12-7. Route two antenna cables (21) and (22) along rear (26), two intermediate (28), and front (29) cargo bed supports and along front wheelwell seam (7). Secure with three self-tapping screws (10) and loop clamps (27), existing self-tapping screw (11) and loop clamp (25), screw (9), loop clamp (8), and nut (6).
- 12-8. Coil antenna cable (22) and secure to inside of taillight closeout cover with tiedown strap (16).
- 12-9. Remove locknut (12) from screw (18) on upper mounting position of reflector (17). Discard locknut (12).
- 12-10. Install clamp (13) on antenna cable (22) and secure to existing screw (18) with locknut (12).

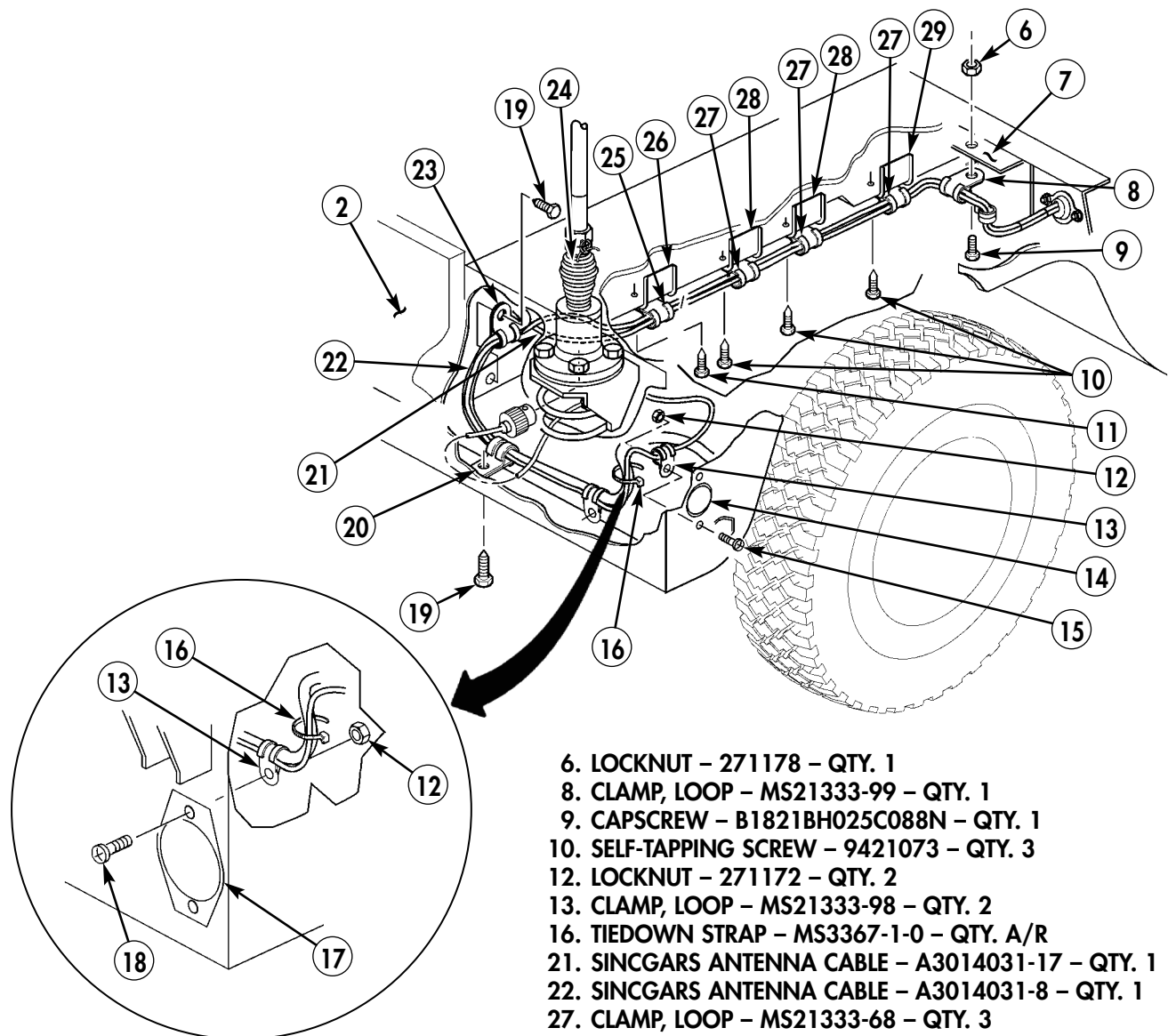

- 6. LOCKNUT - 271178 - QTY. 1
- 8. CLAMP, LOOP - MS21333-99 - QTY. 1
- 9. CAPSCREW - B1821BH025C088N - QTY. 1
- 10. SELF-TAPPING SCREW - 9421073 - QTY. 3
- 12. LOCKNUT - 271172 - QTY. 2
- 13. CLAMP, LOOP - MS21333-98 - QTY. 2
- 16. TIEDOWN STRAP - MS3367-1-0 - QTY. A/R
- 21. SINGARS ANTENNA CABLE - A3014031-17 - QTY. 1
- 22. SINGARS ANTENNA CABLE - A3014031-8 - QTY. 1
- 27. CLAMP, LOOP - MS21333-68 - QTY. 3

Figure 5-88.

NOTE

If installing right side antenna cable only, proceed to step 12-22.

12-11. Route antenna cable (21) to antenna base (30).

12-12. Attach antenna cable (21) to antenna base (30).

NOTE

Reflector not shown.

12-13. Remove locknut (12) from screw (42) on lower mounting position of reflector. Discard locknut (12).

12-14. Install clamp (13) on antenna cable (21) and secure to existing screw (42) with locknut (12).

12-15. Remove locknut (12) from screw (41) on lower mounting position of reflector (40). Discard locknut (12).

12-16. Install clamp (13) on antenna cable (21) and secure to existing screw (41) with locknut (12).

12-17. Remove five existing screws (31) securing taillight wiring harness (32) and SINGARS antenna cable (21) on rear cargo bed support.

12-18. Route antenna cable (21) along existing taillight wiring harness (32) on rear cargo bed support (26) and secure with five existing loop clamps (33), (34), (35), (36), (37) and existing self-tapping screws (31).

12-19. Remove two existing screws (31) securing taillight wiring harness (32) on side of body (2) and D-beam.

12-20. Route antenna cable (21) along existing taillight wiring harness on left-side bed and D-beam with two existing loop clamps (38) and (39), and existing self-tapping screws (31).

12-21. Coil antenna cable (21) and secure to inside of taillight closeout cover with tiedown strap (16).

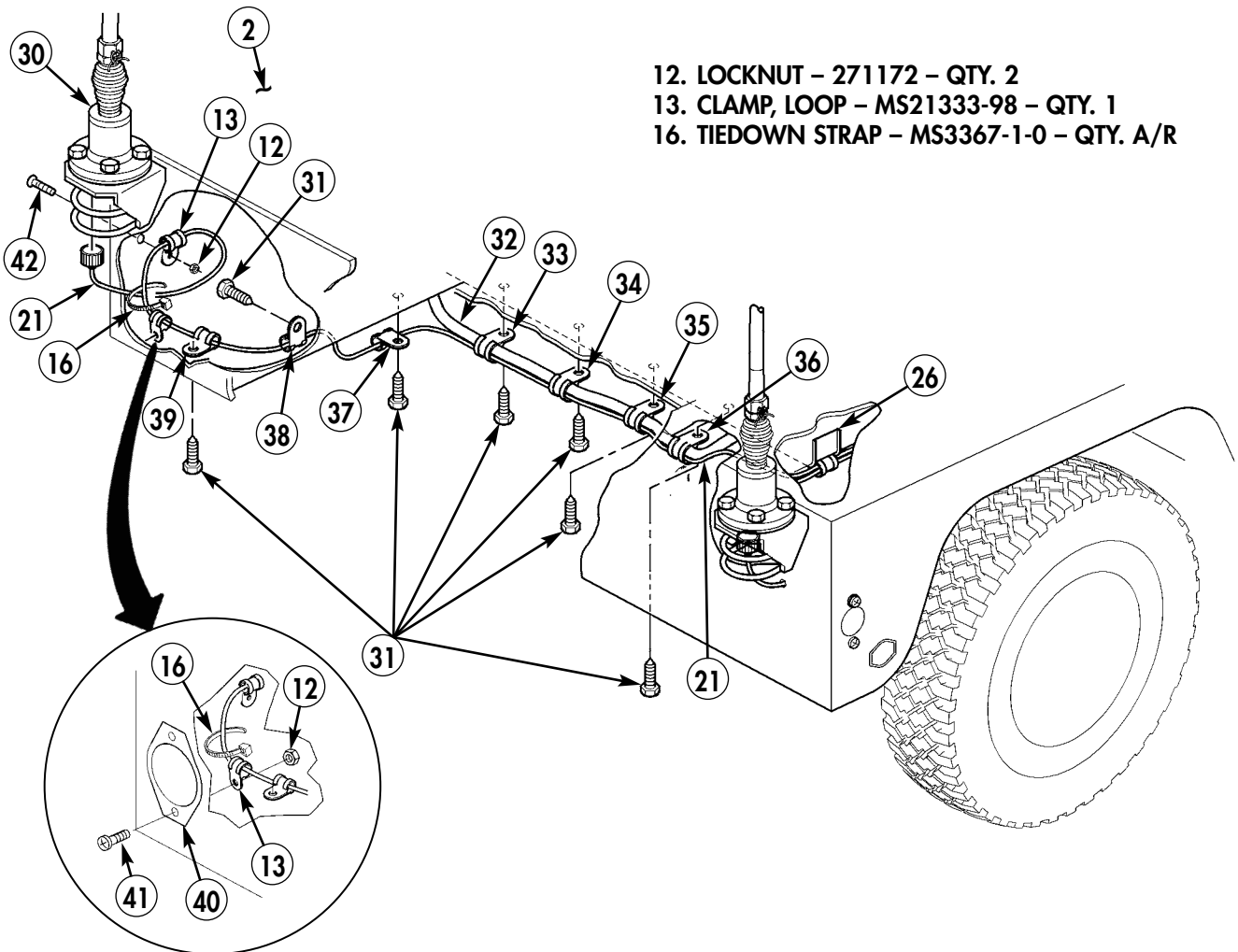

Figure 5-89.

- 12-22.** Route two antenna cables (21) and (22) through right wheelwell/utility area with existing grommet, retainer, screws, and plain-assembled nuts. (Refer to TM 9-2320-387-24.)

NOTE

Early production vehicles do not have SINCGARS installed.
Loop clamps and hardware on right rear seat/utility area and tunnel shelf may or may not exist.

- 12-23.** Remove screw (51), loop clamp (44), and locknut (43) from right wheelwell utility area (52). Discard locknut (43).
- 12-24.** Remove loop clamp (44) and self-tapping screw (10) from tunnel shelf (50).
- 12-25.** Remove three self-tapping screws (48), loop clamps (47), washers (46), and evaporator wiring harness (49) from tunnel insulation (45) and tunnel shelf (50).
- 12-26.** Route two antenna cables (21) and (22) along right rear seat/utility area (52).
- 12-27.** Secure two antenna cables (21) and (22) to tunnel shelf (50) with loop clamp (44) and self-tapping screw (10).
- 12-28.** Secure two antenna cables (21) and (22) to rear seat/utility area (52) with existing loop clamp (44), screw (51), and locknut (43).
- 12-29.** Route two antenna cables (21) and (22) under tunnel insulation (45) towards integrated rack.
- 12-30.** Install tunnel insulation (45), and evaporator wiring harness (49) to tunnel shelf (50) with three existing self-tapping screws (48), loop clamps (47), and washers (46).

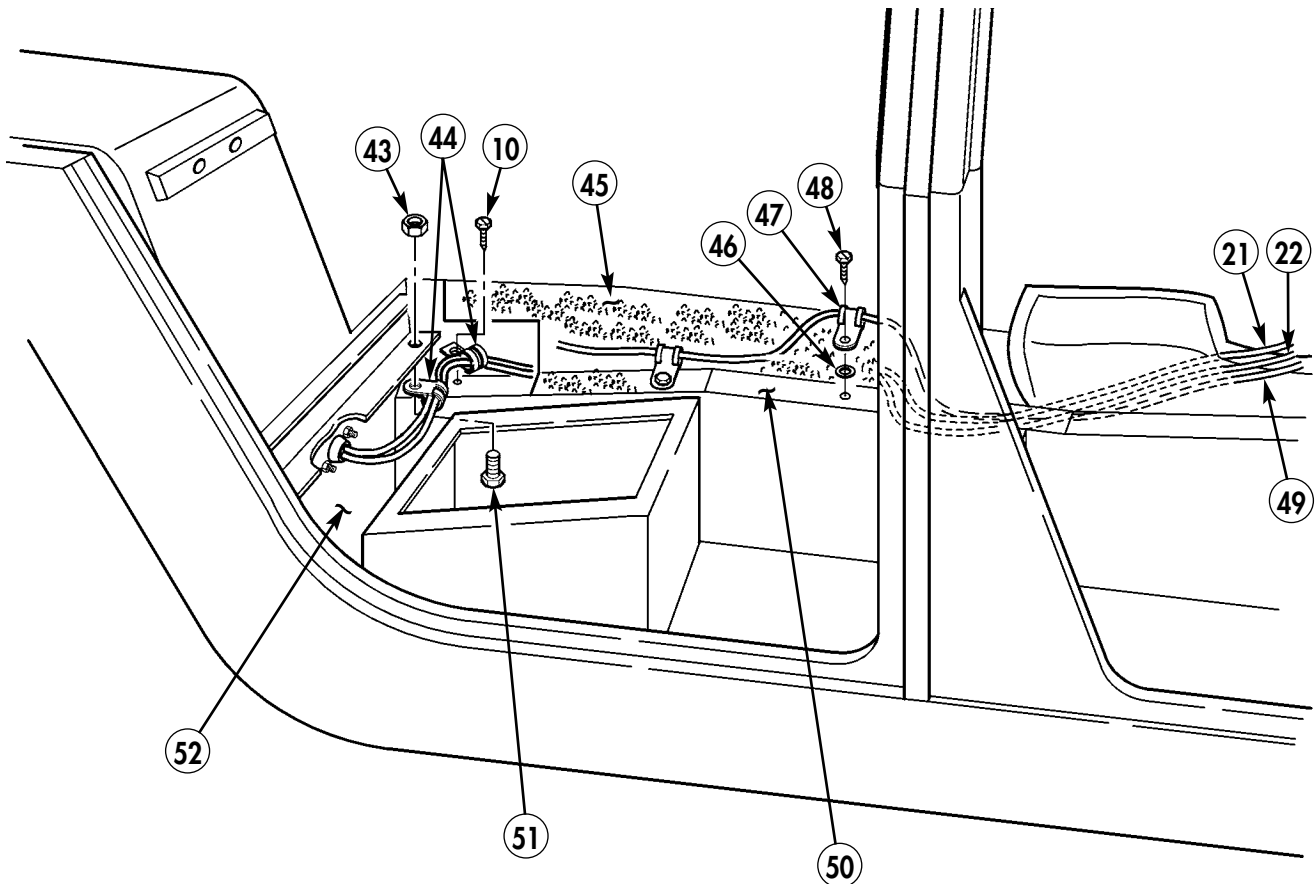

- 10. SELF-TAPPING SCREW – 9421073 – QTY. 1**
43. LOCKNUT – 271166 – QTY. 1

- 44. CLAMP, LOOP – MS21333-68 – QTY. 2**
51. SCREW – MS35206-267 – QTY. 1

Figure 5-90.

12-31. Route antenna cables (21) and (22) through integrated rack (54) to VAA (53).

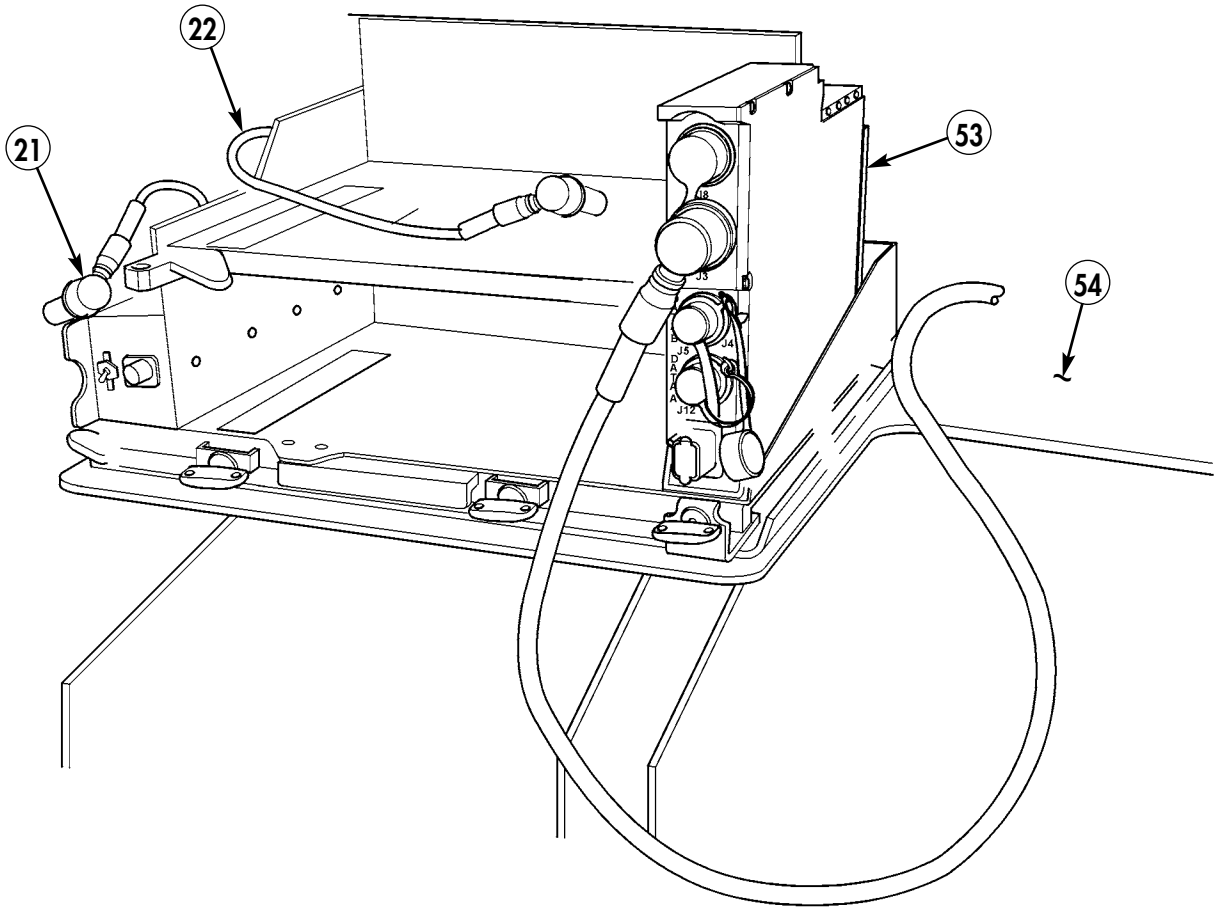
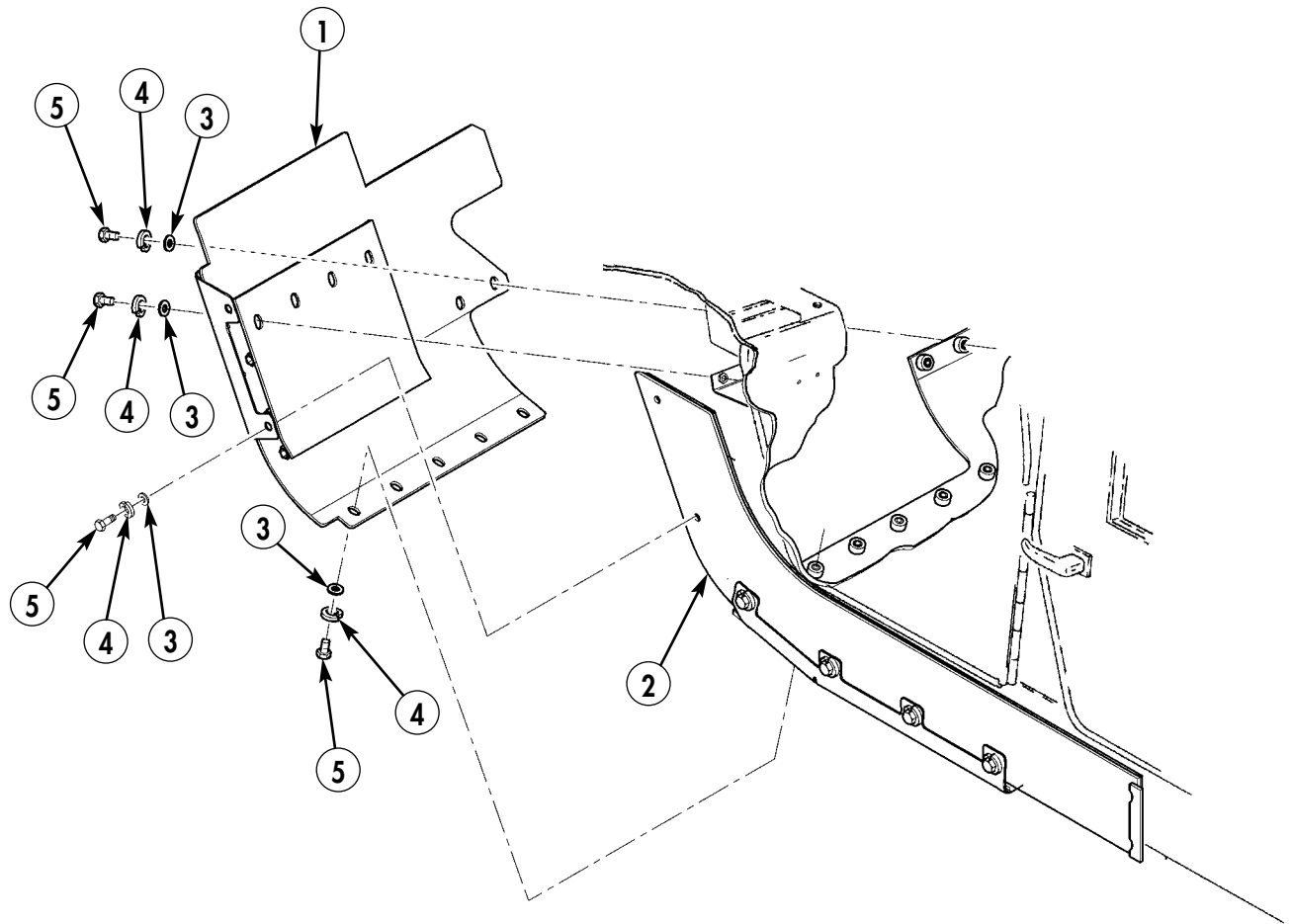

Figure 5-91.

12-32. Install wheelwell plate (1) on vehicle (2) with thirteen existing bolts (5), lockwashers (4), and fender washers (3).



4. LOCKWASHER – MS35338-46 – QTY. 11

Figure 5-92.

Section XIII. VIC-3 MOUNTING INSTALLATION: FFCS/L

- 13-1.** Install left-side FFCS/L (5) on left-hand mounting bracket (4) with two screws (2), washers (3), washers (6), lockwashers (7), and nuts (8).
- 13-2.** Remove two existing screws (1), lockwashers (11), and washers (10) from left-side rear evaporator cover (9).
- 13-3.** Secure left-side FFCS/L (5) and left-hand mounting bracket (4) on left-side rear evaporator cover (9) with two existing screws (1), lockwashers (11), and existing washers (10). Do not tighten screws (1).

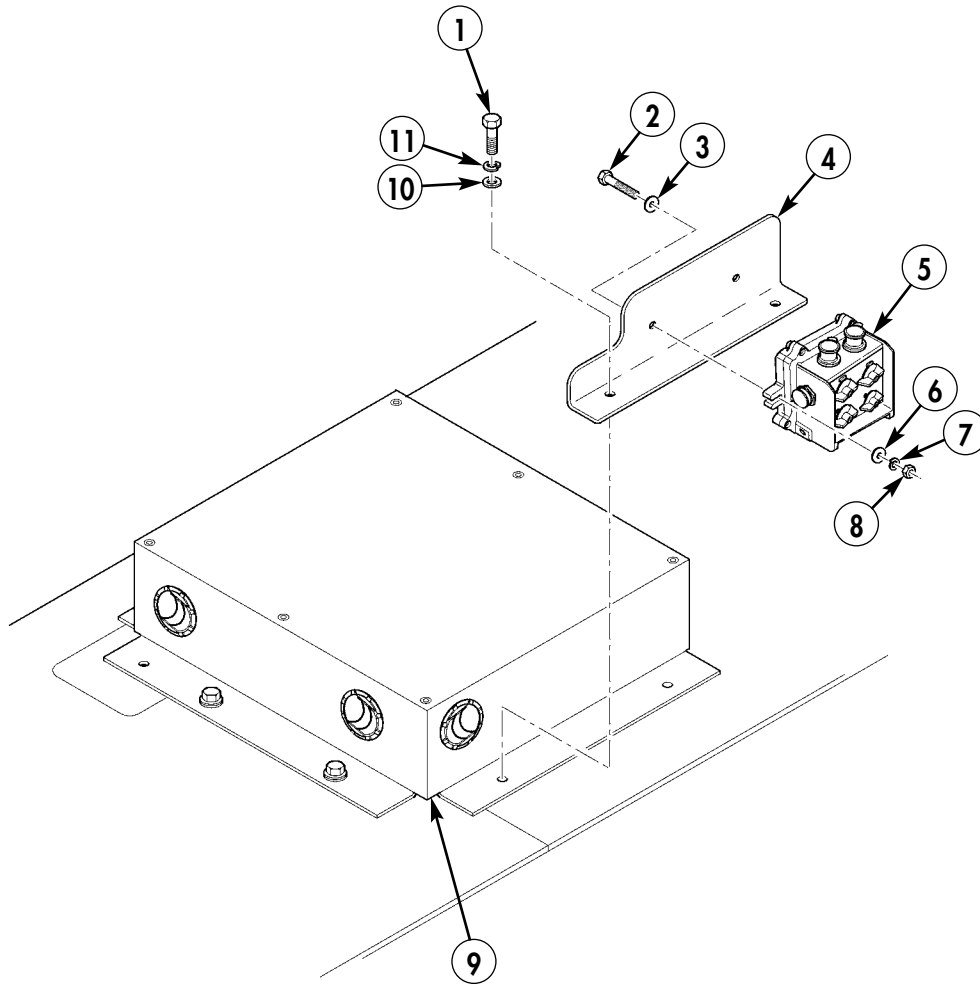

- 2. CAPSCREW – B1821BH031C125N – QTY. 2
- 3. WASHER – 2436162 – QTY. 2
- 4. LEFT-HAND MOUNTING BRACKET – 6500695-1 – QTY. 1
- 5. FULL FUNCTION CREW STATION/LIGHT – A3206624 – QTY. 1
- 6. WASHER – 10910174-19 – QTY. 2
- 7. LOCKWASHER – 120214 – QTY. 2
- 8. NUT – 120376 – QTY. 2
- 11. LOCKWASHER – MS35338-44 QTY. 2

Figure 5-93.

- 13-4. Install right-side FFCS/L (5) on right-hand mounting bracket (14) with two screws (2), washers (3), washers (6), lockwashers (7), and nuts (8).
- 13-5. Remove two existing screws (12), lockwashers (11), and washers (13) from right-side rear evaporator cover (9).
- 13-6. Secure right-side FFCS/L (5) and right-hand mounting bracket (14) on right-side rear evaporator cover (9) with two existing screws (12), lockwashers (11), and washers (13). Do not tighten screws (12).

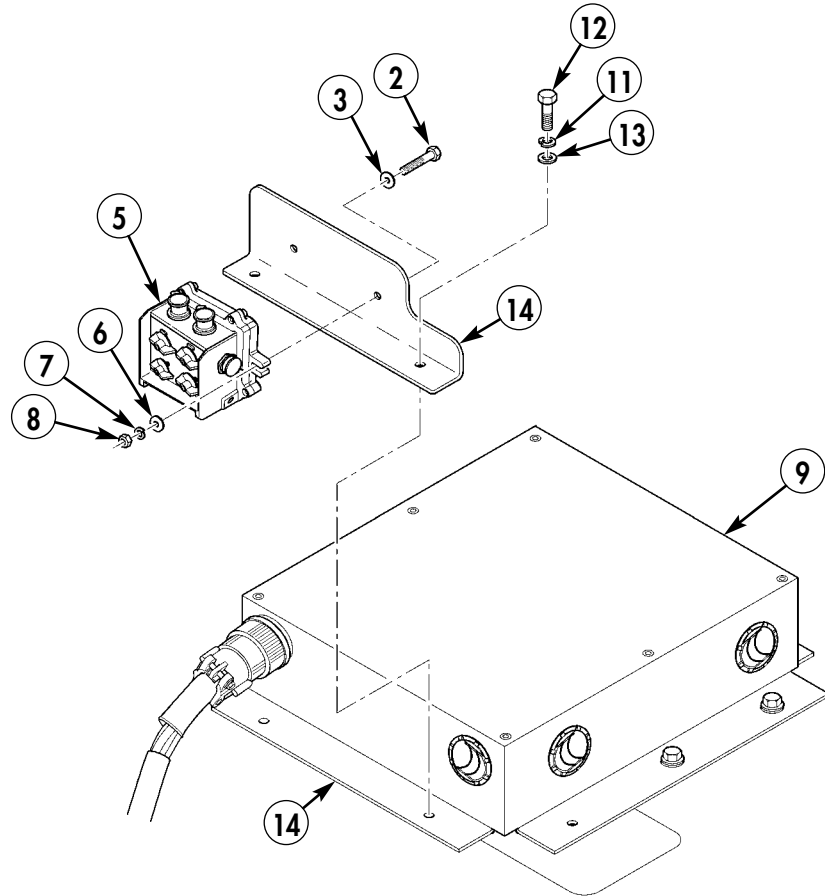

- 2. CAPSCREW – B1821BH031C125N – QTY. 2
- 3. WASHER – 2436162 – QTY. 2
- 5. FULL FUNCTION CONTROL STATION/LIGHT – A3206624 – QTY. 1
- 6. WASHER – 10910174-19 – QTY. 2
- 7. LOCKWASHER – 120214 – QTY. 2
- 8. NUT – 120376 – QTY. 2
- 11. LOCKWASHER – MS35338-44 – QTY. 2
- 14. RIGHT-HAND MOUNTING BRACKET – 6500695-2 – QTY. 1

Figure 5-94.

13-7. Connect P2 connector (16) from cable assembly (17) to "Station-In" connector (15) on left side rear FFCS/L (5).

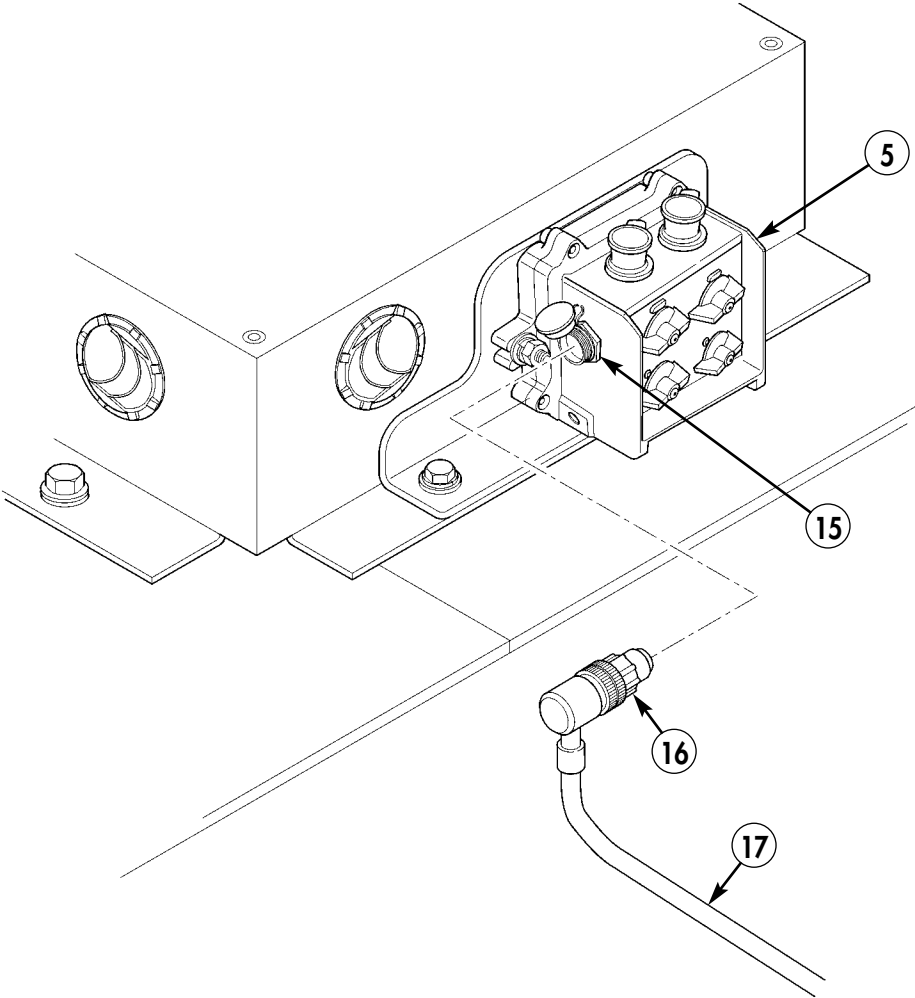

17. CABLE ASSEMBLY – A3206018-6 – QTY. 1

Figure 5-95.

- 13-8. From "Station-In" connector (18), route cable assembly (17) under left side FFCS/L (5) to rear of evaporator cover (9), along rear of evaporator cover (9) to right side rear FFCS/L (5).
- 13-9. Route P1 connector (19) of cable assembly (17) under right side rear FFCS/L (5) and connect to "Station-Out" connector (20) on right side rear FFCS/L (5).

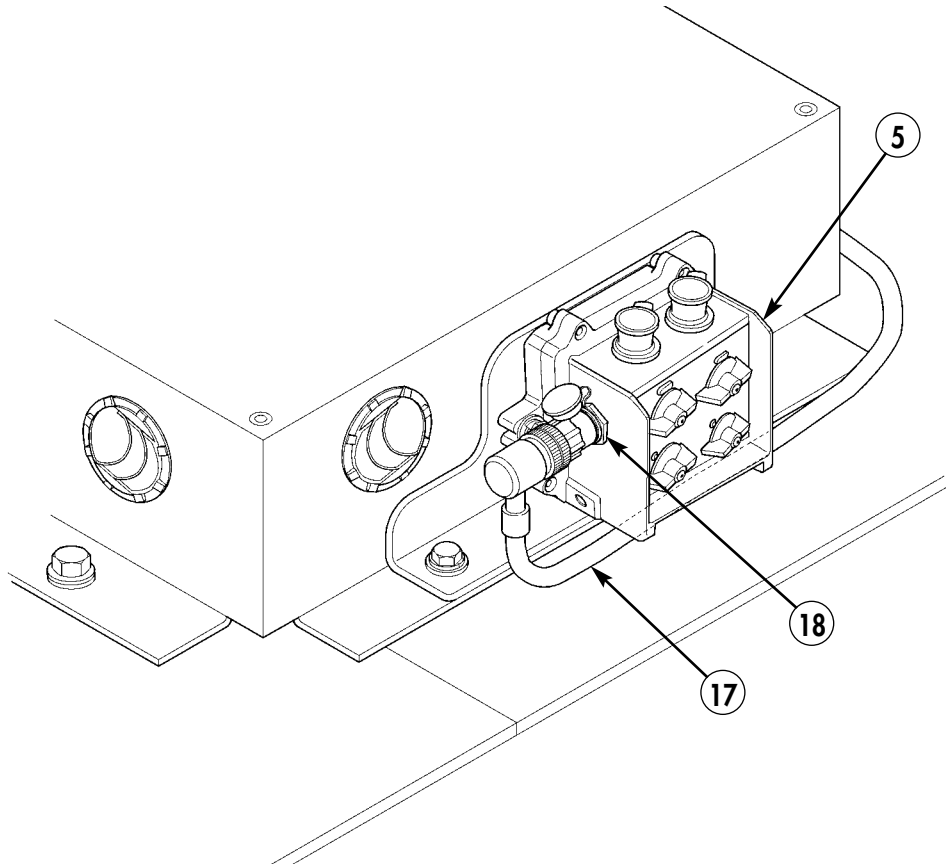

Figure 5-96.

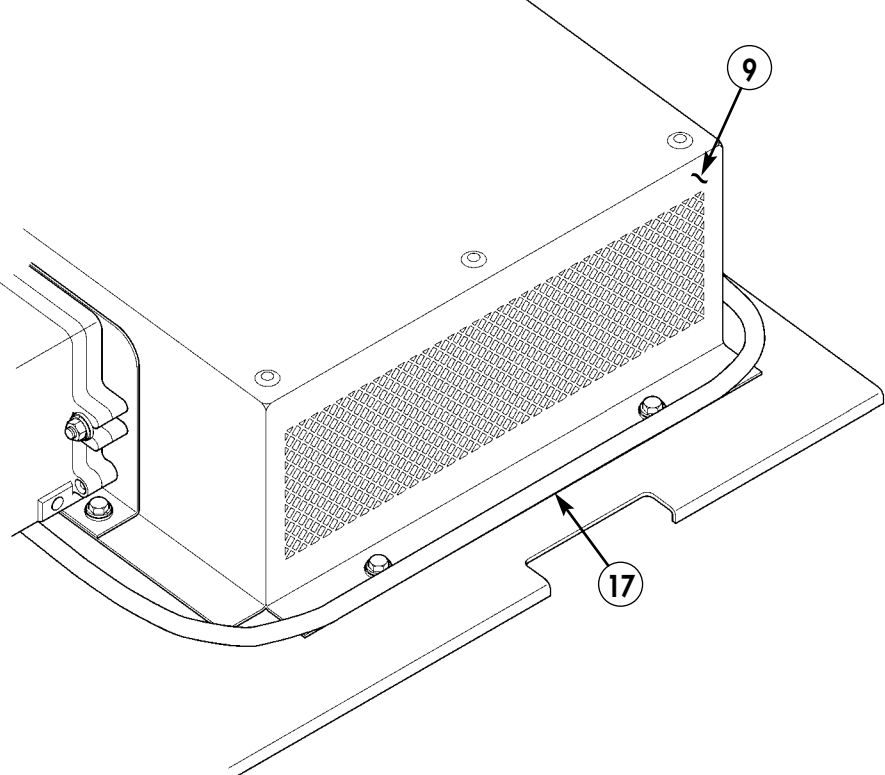

Figure 5-97.

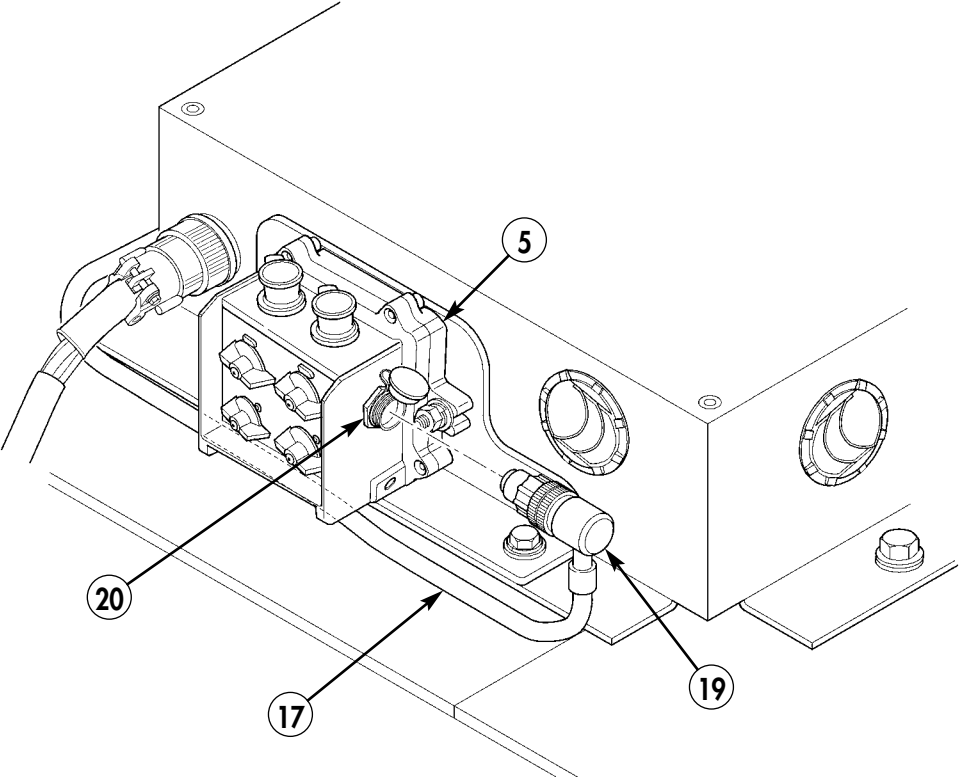
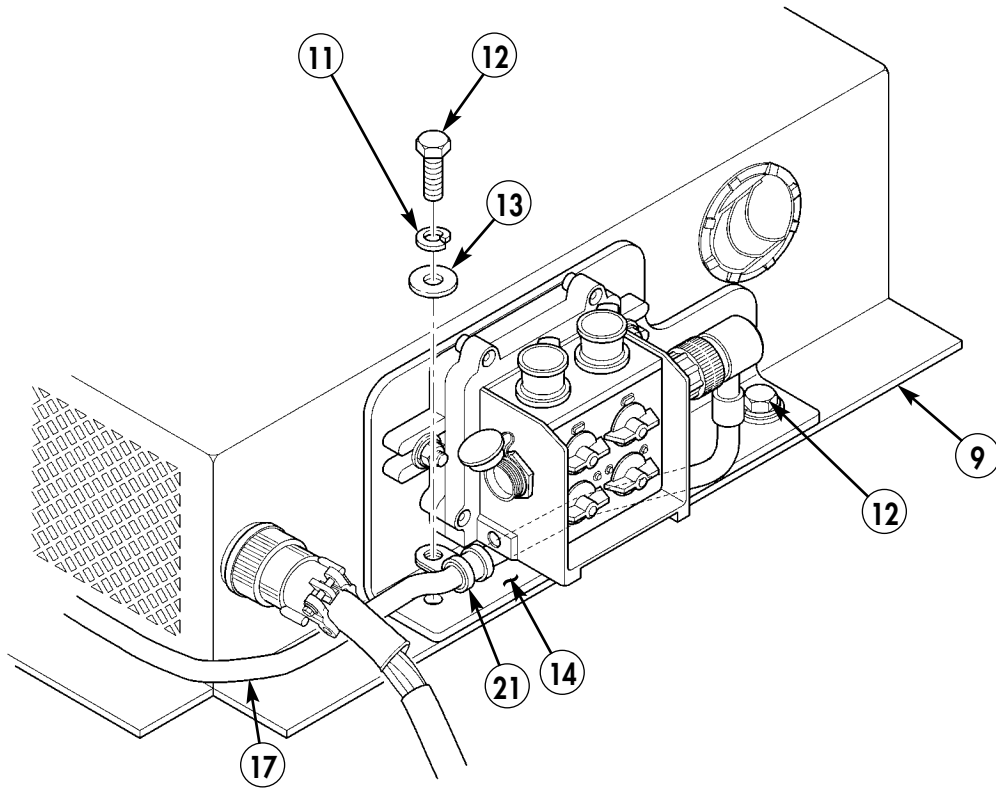

Figure 5-98.

- 13-10. Install clamp (21) on cable assembly (17) on right side of rear evaporator cover (9).
- 13-11. Remove rear screw (12), lockwasher (11), and washer (13) from right-hand mounting bracket (14).
- 13-12. Secure clamp (21) and cable assembly (17) to rear right-hand mounting bracket (14) with screw (12), lockwasher (11), and washer (13). Tighten screws (12).



21. CLAMP – MS21333-100 – QTY. 1

Figure 5-99.

- 13-13.** Install clamp (21) on cable assembly (17) on left side of rear evaporator cover (9).
- 13-14.** Remove rear screw (1), lockwasher (11), and washer (10) from left-hand mounting bracket (4).
- 13-15.** Secure clamp (21) and cable assembly (17) to rear left-hand mounting bracket (4) with screw (1), lockwasher (11), and washer (10). Tighten screw (1).

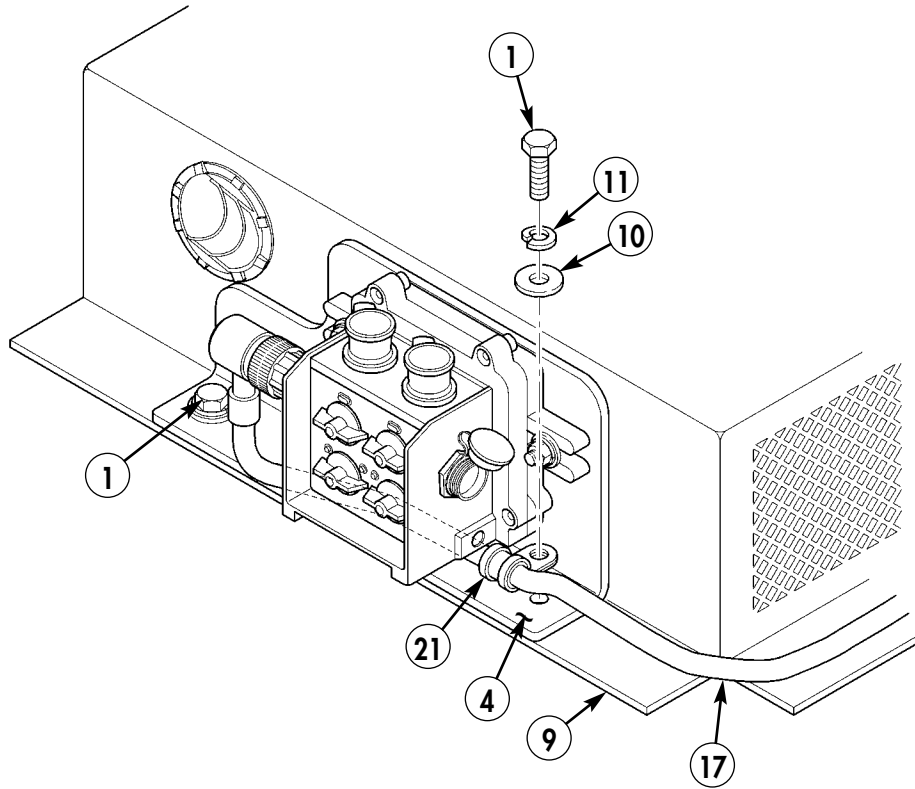

21. CLAMP – MS21333-100 – QTY. 1

Figure 5-100.

13-16. Route highway cables (23) and (24) from rear of right-side cab enclosure panel (22) towards front of vehicle.

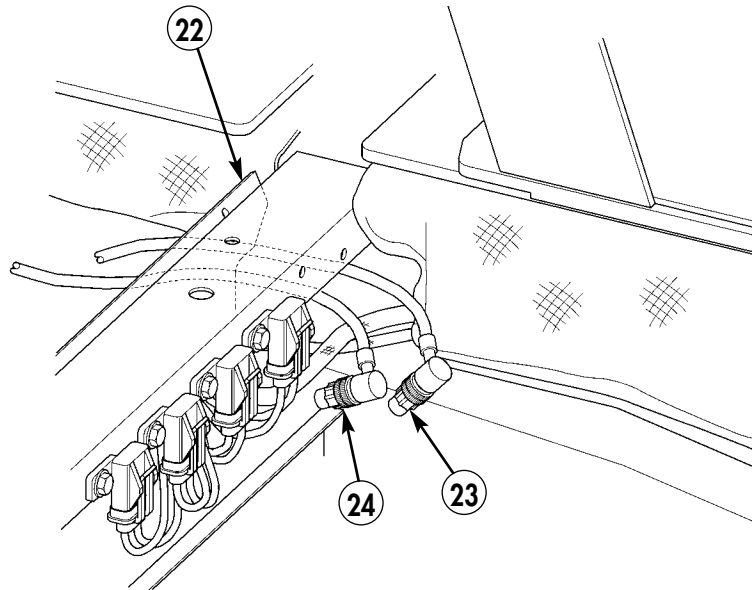

23. HIGHWAY CABLE - A3206018-12 - QTY. 1

24. HIGHWAY CABLE - A3206018-9 - QTY.1

Figure 5-101.

13-17. Route highway cables (23) and (24) under right-side tunnel insulation (26) to radio rack (25).

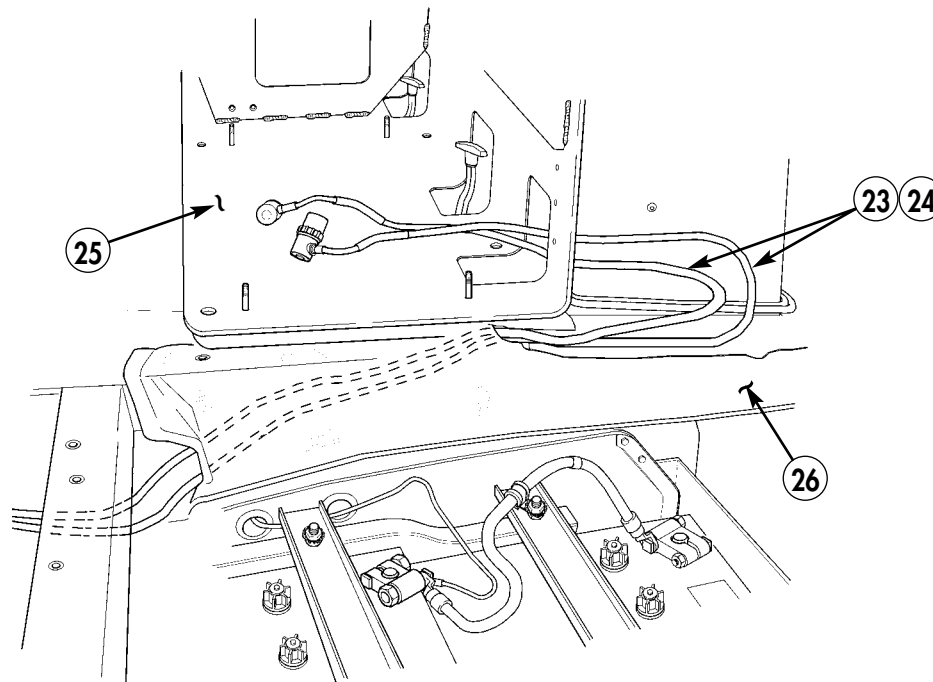

Figure 5-102.

- 13-18. Route two highway cables (23) and (24) along lower mounting surface (32).
- 13-19. Continue highway cable (24) to MCS/L (35) and connect P1 connector (33) to "Station-Out" connector (34) on MCS/L (35).
- 13-20. Continue highway cable (23) through two access cutouts (27) to upper mounting surface (28), and connect P2 connector (29) to "Station-In" connector (30) on front FFCS/L (31).

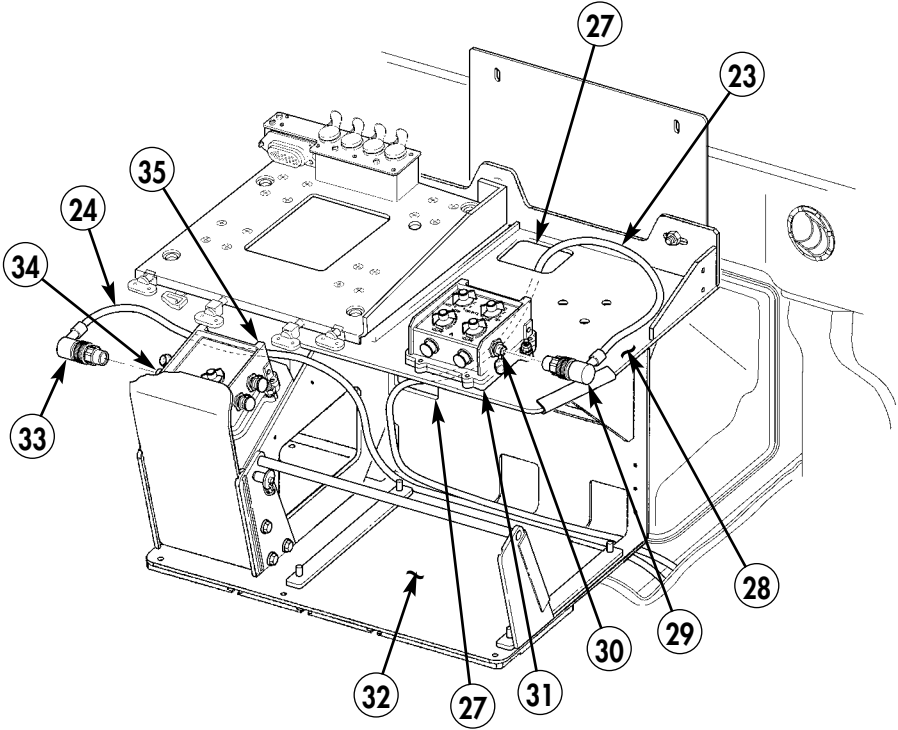
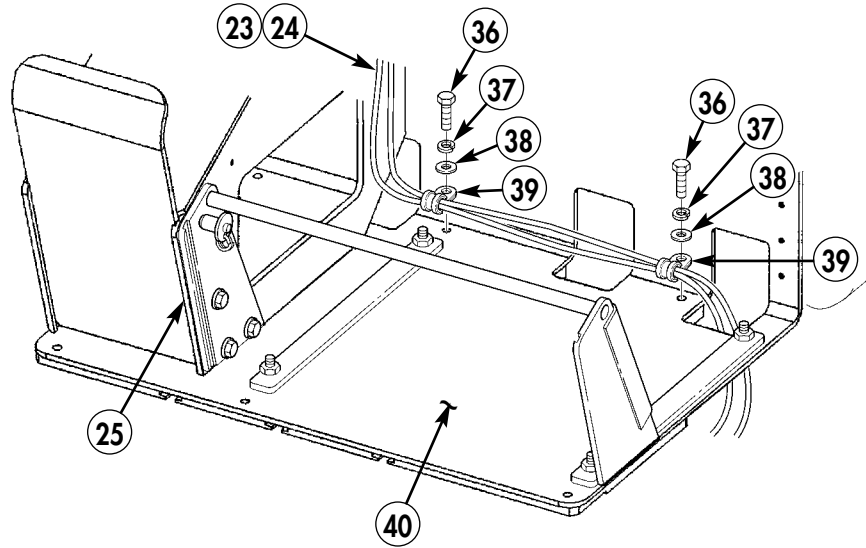

Figure 5-103.

- 13-21. Remove two screws (36), lockwashers (37), and washers (38) from lower mounting surface (40) on integrated radio rack (25). Discard lockwashers (37).
- 13-22. Install two clamps (39) on two highway cables (23) and (24) and secure to lower mounting surface (40) of integrated radio rack (25) with two screws (36), lockwashers (37), and washers (38).



37. LOCKWASHER – MS35338-44 – QTY. 2

Figure 5-104.

- 13-23. Remove three screws (42) and clamps (41) from rear A/C electrical cable (43) and tunnel insulation (26).

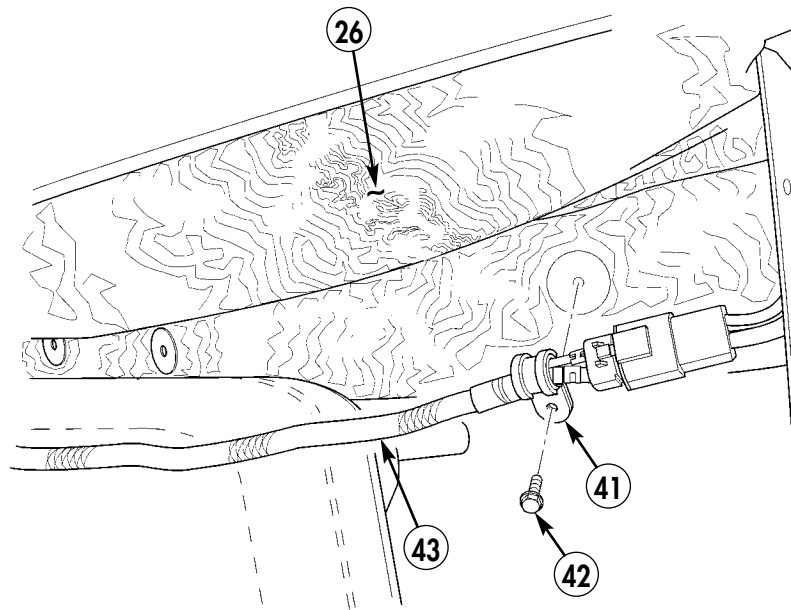

Figure 5-105.

13-24. Route two highway cables (23) and (24) with rear A/C electrical cable (43) on right-side tunnel shelf (44) to rear evaporator cover (9).

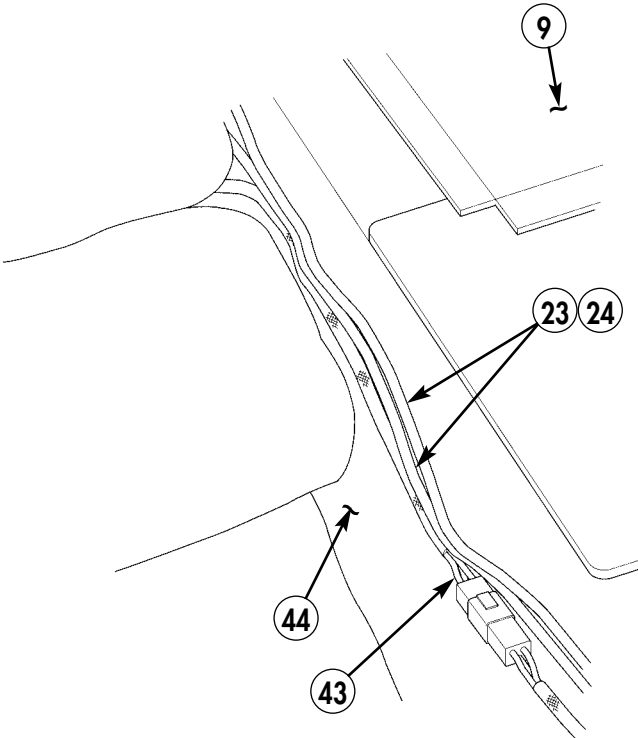

Figure 5-106.

13-25. Continue routing highway cable (23) from right side of rear evaporator cover (9) along rear of evaporator cover (9) to left rear FFCS/L (5).

13-26. Connect P1 connector (45) of highway cable (23) to "Station-Out" connector (46) on left rear FFCS/L (5).

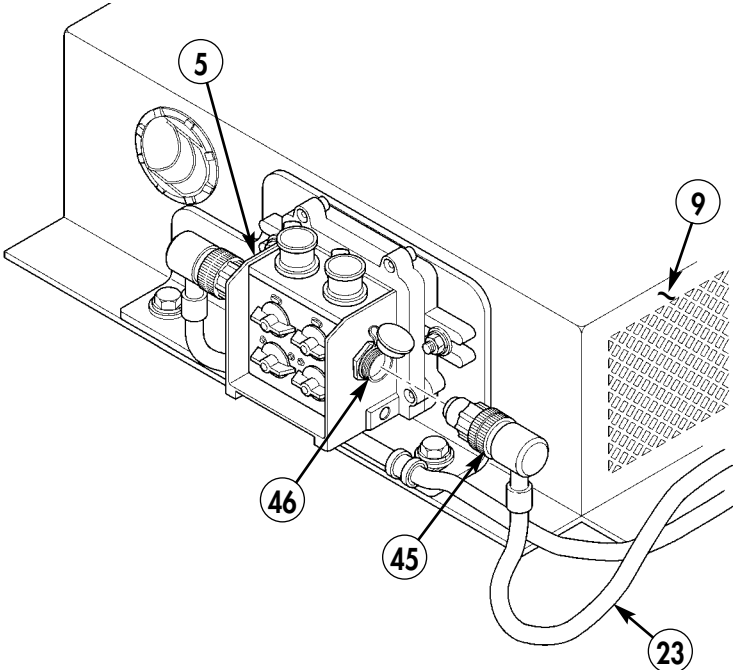

Figure 5-107.

13-27. Connect P2 connector (48) of highway cable (24) to "Station-In" connector (47) on right rear FFCS/L (5).

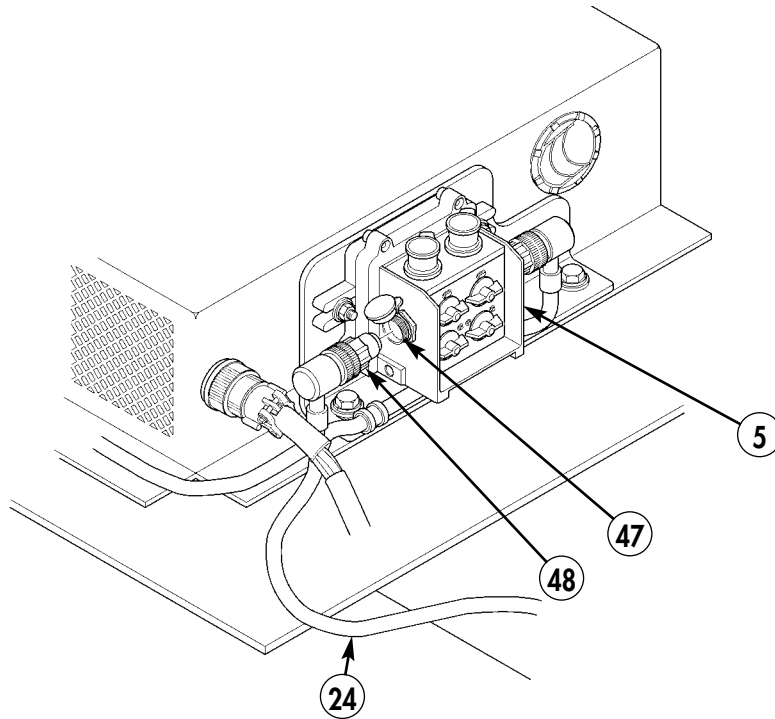
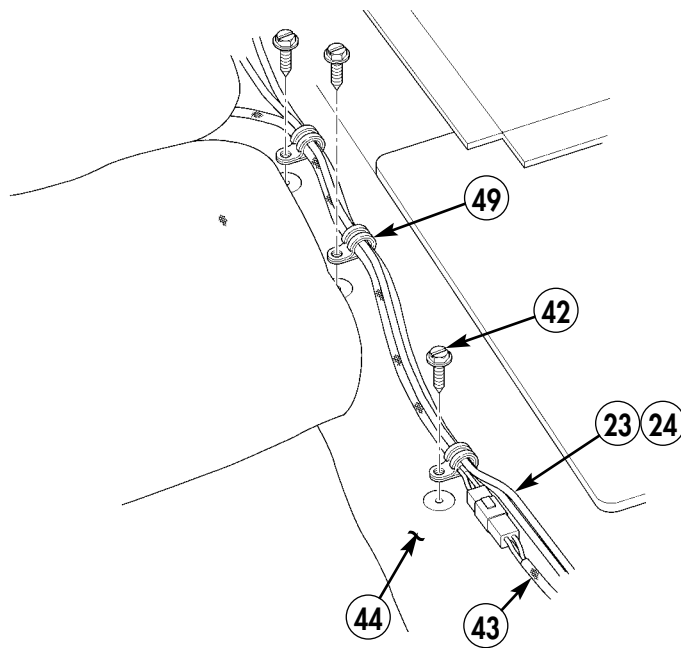

Figure 5-108.

13-28. Secure two highway cables (23) and (24) and rear A/C electrical cable (43) to tunnel shelf (44) with three clamps (49) and existing screws (42).



49. CLAMP – MS21333-76 – QTY. 3

Figure 5-109.

13-29. Secure two highway cables (23) and (24) with rear A/C electrical cable (43) on right rear corner of tunnel shelf (44) with tie-down strap (50).

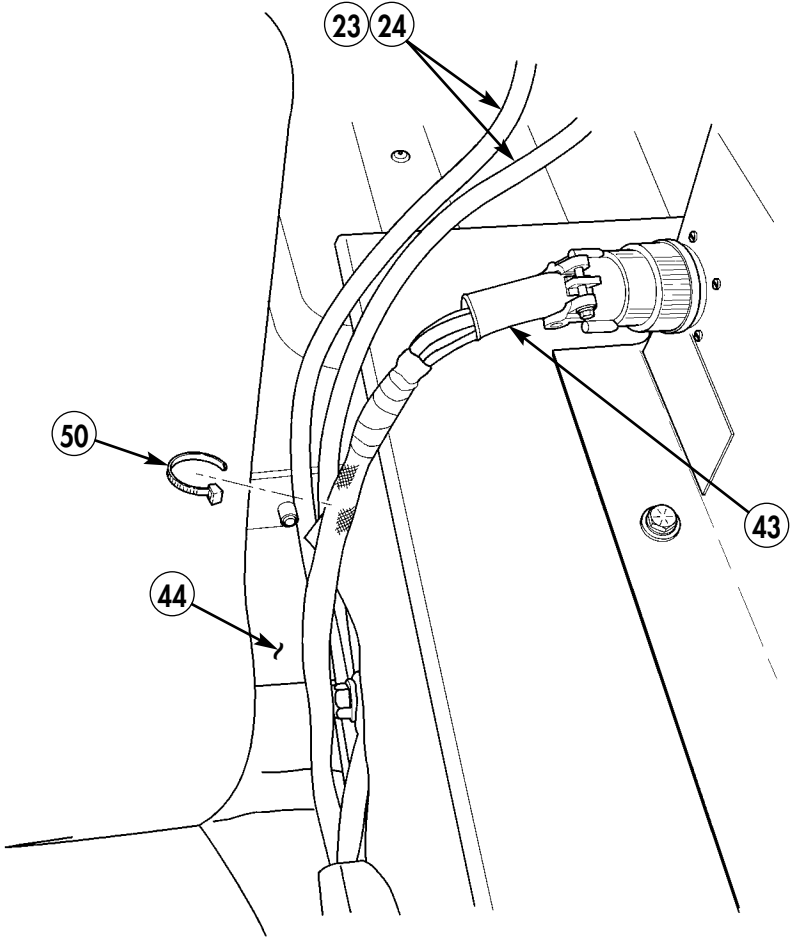

50. TIEDOWN STRAP – MS3367-1-0 – QTY. 1

Figure 5-110.

- 13-30. Position excess of cables (17) and (23) behind evaporator cover (9).
- 13-31. Remove two screws (52), lockwashers (51), and washers (53) from rear evaporator cover (9).
- 13-32. Position clamp (54) on cables (17) and (23) and secure to left side of rear evaporator cover (9) with existing screw (52), lockwasher (51), and washer (53).
- 13-33. Position clamp (55) on cables (17) and (23) and secure to right side of rear evaporator cover (9) with existing screw (52), lockwasher (51), and washer (53).

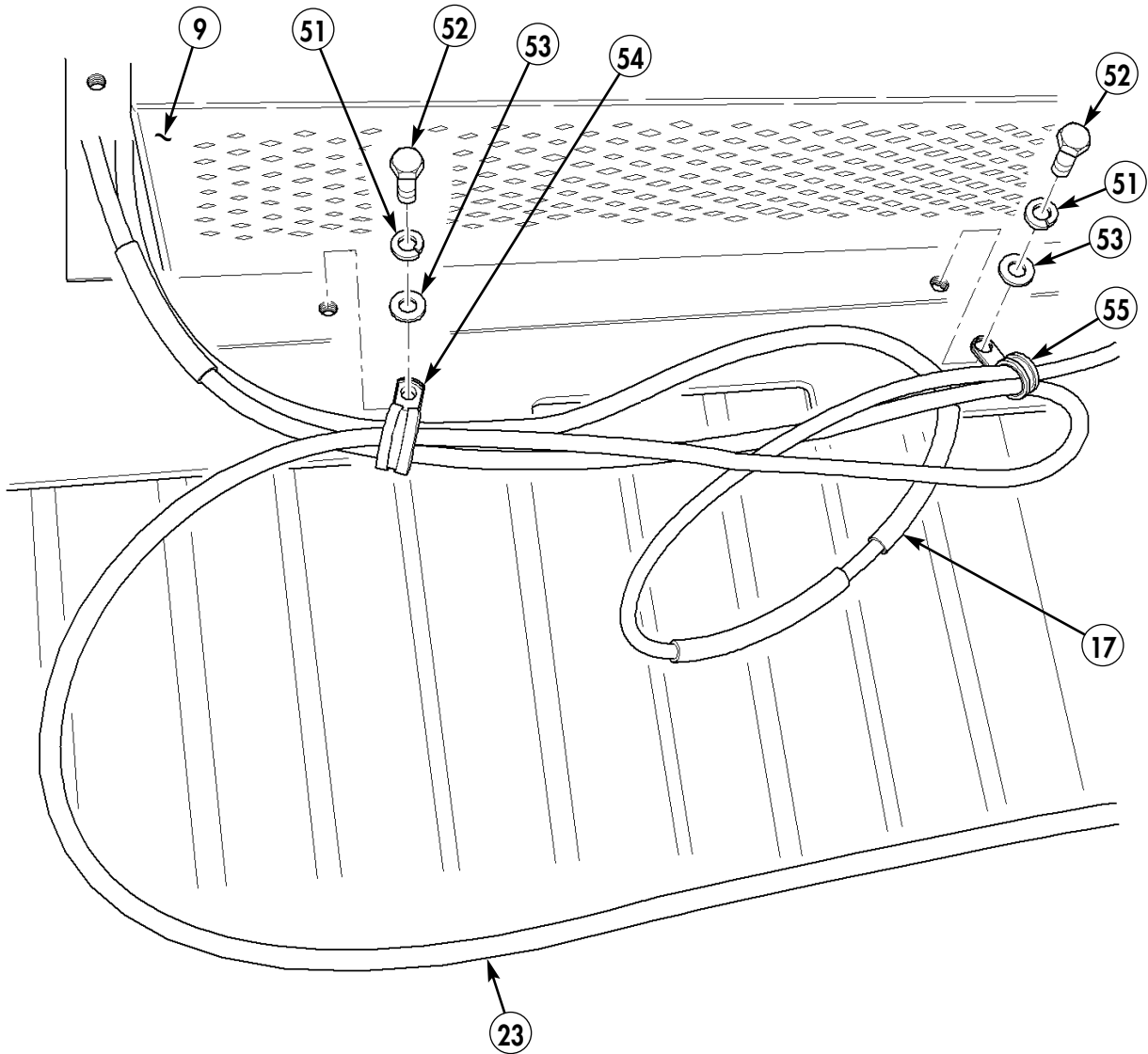

- 51. LOCKWASHER - MS35338-44 - QTY. 2
- 54. CLAMP - MS21333-105 - QTY. 1
- 55. CLAMP - MS21333-104 - QTY. 1

Figure 5-111.

13-34. Secure excess highway cables (17) and (23) to rear of evaporator cover (9) with tie-down strap (56).

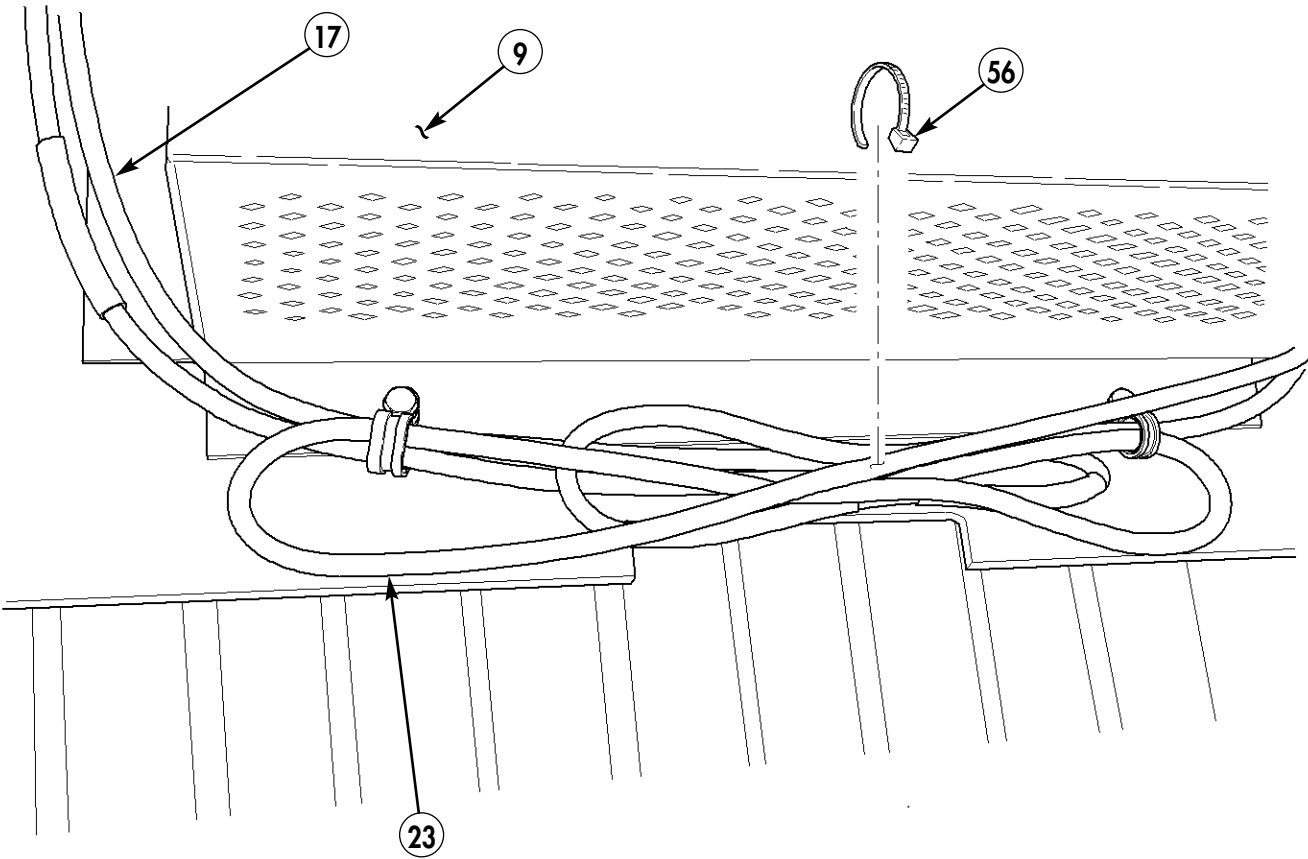

56. TIEDOWN STRAP – MS3367-7-0 – QTY. 1

Figure 5-112.

- 13-35.** Connect P2 connector (66) of cable assembly (68) to "Station-Out" connector on front FFCS/L (31).
- 13-36.** Route cable assembly (68) against support rail (69) and connect P1 connector (72) to "Station-In" connector (74) on MCS/L (35).
- 13-37.** Connect P1 connector (67) of cable assembly (71) to power connector (61) on MCS/L (35).
- 13-38.** Route cable assembly (71) under and through two access cutouts (27) to upper mounting surface (28) and connect to A4J2 connector (65) on MT6352/VRC Mount (57).
- 13-39.** Connect P1 connector (76) of cable assembly (73) to "Radio B" connector (75) on MCS/L (35).
- 13-40.** Route cable assembly (73) under and through two access cutouts (27) to upper mounting surface (28) and connect to A4J4 connector (64) on MT6352/VRC mount (57).
- 13-41.** Connect P1 connector (76) of cable assembly (77) to "Radio A" connector (78) on MCS/L (35).
- 13-42.** Route cable assembly (77) to upper mounting surface (28) and connect to A4J3 connector (63) on MT6352/VRC mount (57).
- 13-43.** Secure cables (77) and (24) with tie-down strap (70).
- 13-44.** Locate existing hole (60) on upper mounting surface (28) of radio rack (25) and install screw (62) and washer (58).
- 13-45.** Install clamp (59) on cable assembly (77) and secure with existing screw (62), washer (58), lockwasher (7) and nut (8).
- 13-46.** Secure cable assembly (68) on support rail (69) with two tiedown straps (70).

NOTE:

- Cables, MCS/L and FFCS/L not shown for clarity.
 - If MT6352/VRC mount is not installed, longer screw is required for proper thread length engagement of nut.
- 13-47.** Remove existing screw (79) and washer (81) from MT6352/VRC mount (57) and radio rack (25).
 - 13-48.** Install screw (80) and existing washer (81) in MT6352/VRC mount (57) and radio rack (25).
 - 13-49.** Install clamp (82) on two cables (71) and (73).
 - 13-50.** Secure two cables (71) and (73) and clamp (82) on screw (79) with washer (58), lockwasher (7), and nut (83).

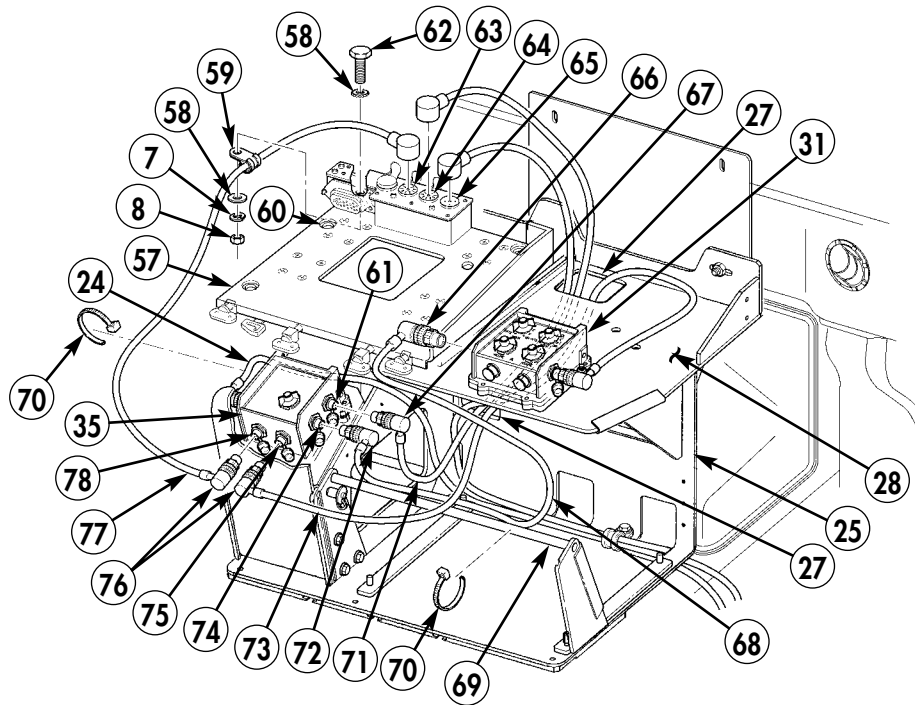

- | | |
|---|--|
| 7. LOCKWASHER - 120214 - QTY. 1 | 68. CABLE ASSEMBLY - A3206018-2 - QTY. 1 |
| 8. NUT - 120376 - QTY. 1 | 70. TIEDOWN STRAP - MS3367-1-0 - QTY. 3 |
| 58. WASHER - 2436162 - QTY. 2 | 71. CABLE ASSEMBLY - A3206017-3 - QTY. 1 |
| 59. CLAMP - MS21333-111 - QTY. 1 | 73. CABLE ASSEMBLY - A3206019-3 - QTY. 1 |
| 62. CAPSCREW - B1821BH031C100N - QTY. 1 | |

Figure 5-113.

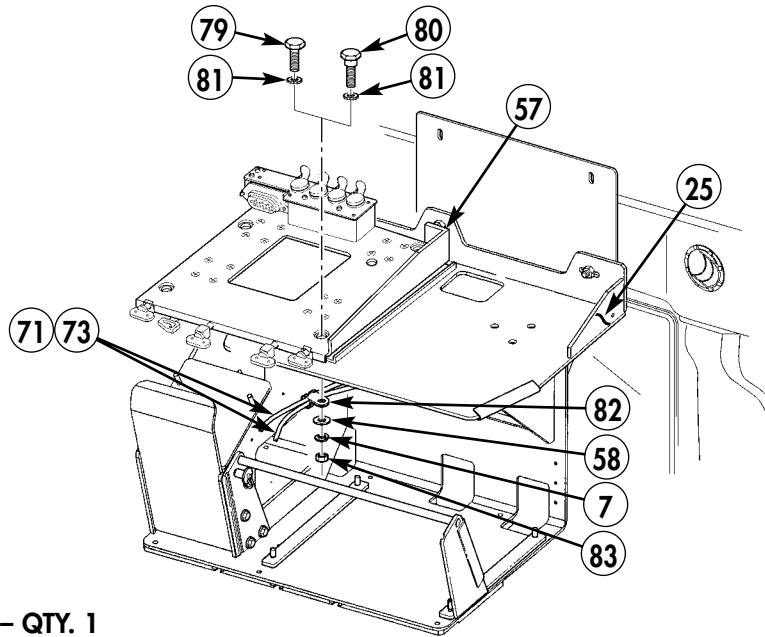

- | |
|---|
| 7. LOCKWASHER - 120214 - QTY. 1 |
| 58. WASHER - 2436162 - QTY. 2 |
| 80. CAPSCREW - B1821BH031F125N - QTY. 1 |
| 82. CLAMP - MS21333-112 - QTY. 1 |

Figure 5-114.

Section XIV. DAGR POWER CABLE ROUTING

NOTE

- Positive wire includes fusible link.
- Refer to TM 9-2320-387-24 for terminal-type connector repair.

- 14-1. Remove screw (5) and air conditioning close out panel (4) from air conditioning duct (3).
- 14-2. Route DAGR power cable (2) behind air conditioning duct (3) to radio rack (1).
- 14-3. Install air conditioning close out panel (4) on air conditioning duct (3) with screw (5).

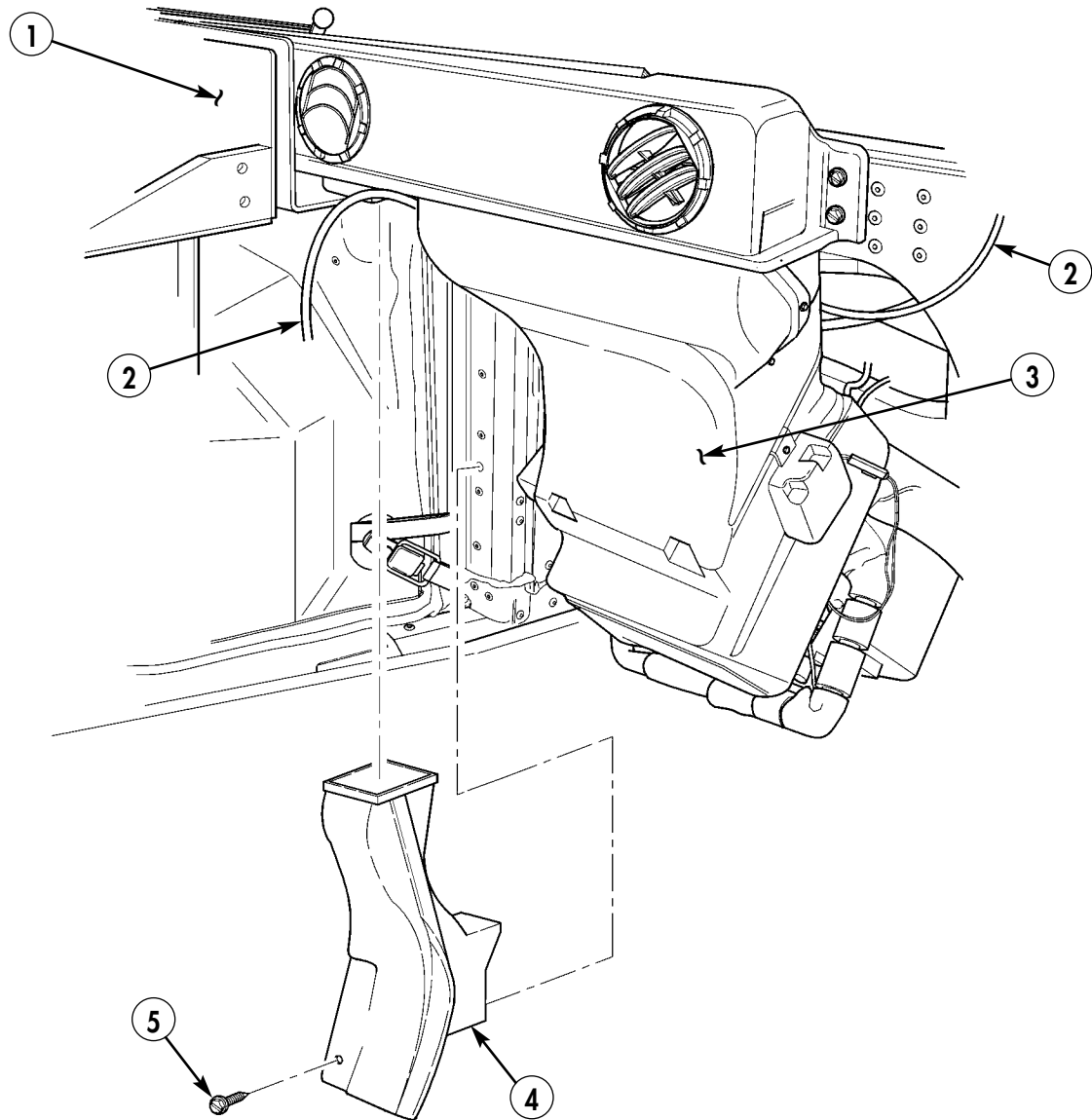

Figure 5-115.

NOTE

Keep excess power cable under insulation.

14-4. Route power cable (2) behind A/C unit (6), under right tunnel insulation (7), to right-hand cab enclosure panel (8).

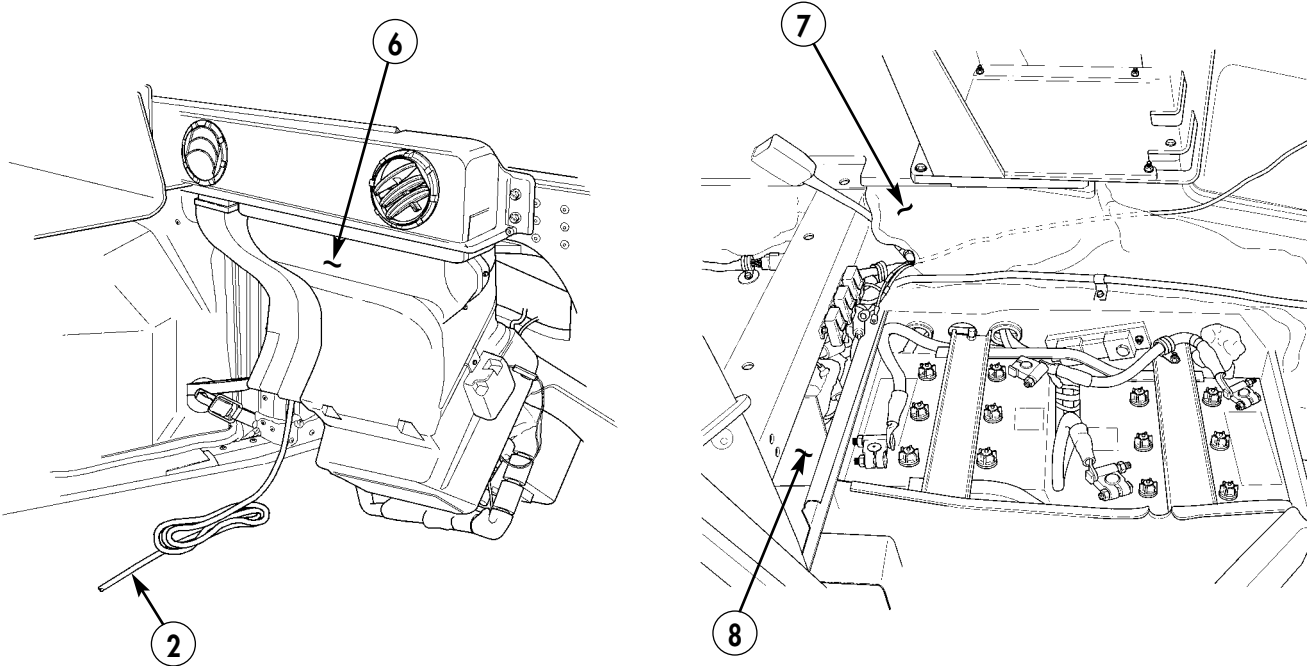
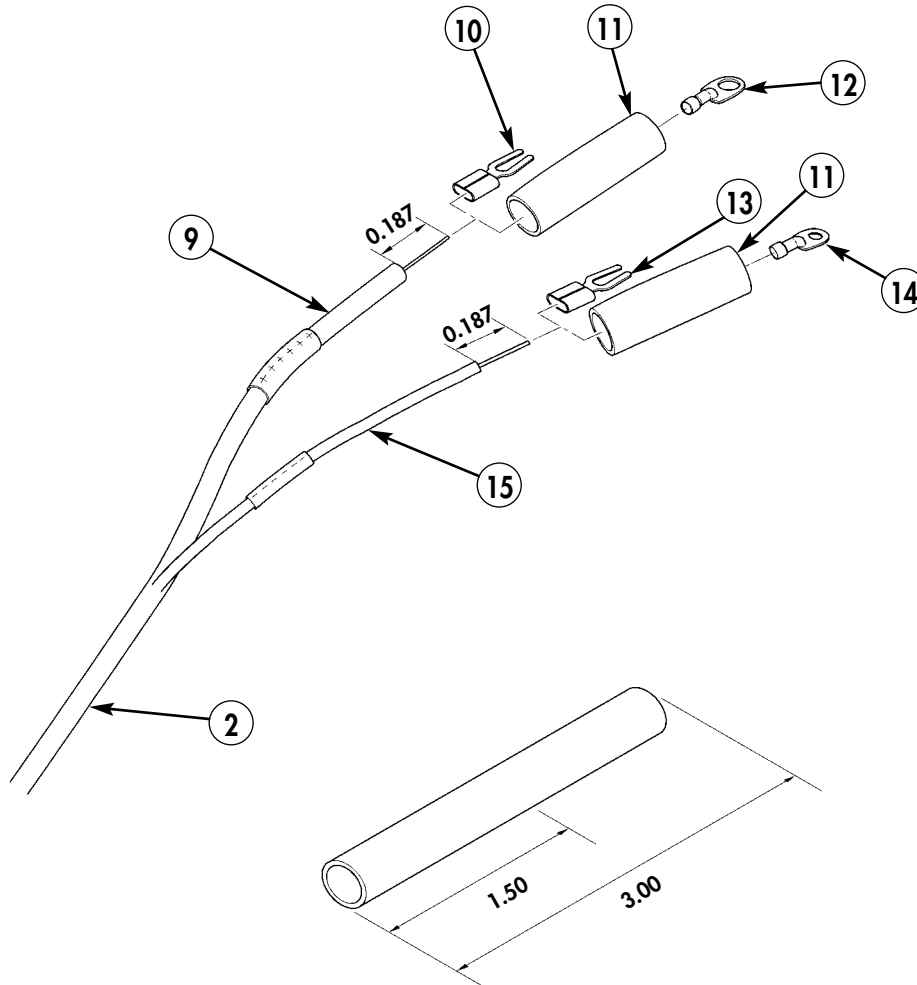

Figure 5-116.

- 14-5. Remove two electrical connectors (10) and (13) from positive (9) and negative (15) wires on DAGR power cable (2).
- 14-6. Remove 0.187-inch of insulation from positive (9) and negative (15) wires on power cable (2).
- 14-7. Attach shrink tubing (11) and terminal lugs (12) and (14) to power cable positive lead (9) and power cable negative lead (15). (Refer to TM 9-2320-387-24 for terminal connector repair.)



- 11. SHRINK TUBING – MS23054/4-103-0 – QTY. 3 INCHES.
- 12. TERMINAL LUG – 7728780 – QTY. 1
- 14. TERMINAL LUG – 7728777 – QTY. 1

Figure 5-117.

- 14-8. Remove terminal board cover (17) from positive terminal board (16).
- 14-9. Remove locknut (19) from positive stud (18) on positive terminal board (16). Discard locknut (19).
- 14-10. Remove locknut (20) from negative stud (21) on negative terminal board (22). Discard locknut (20).
- 14-11. Connect positive terminal (12) to positive stud (18) on positive terminal board (16) with locknut (19).
- 14-12. Connect negative terminal (14) to negative stud (21) on negative terminal board (22) with locknut (20).
- 14-13. Install terminal board cover (17) on positive terminal board (16).

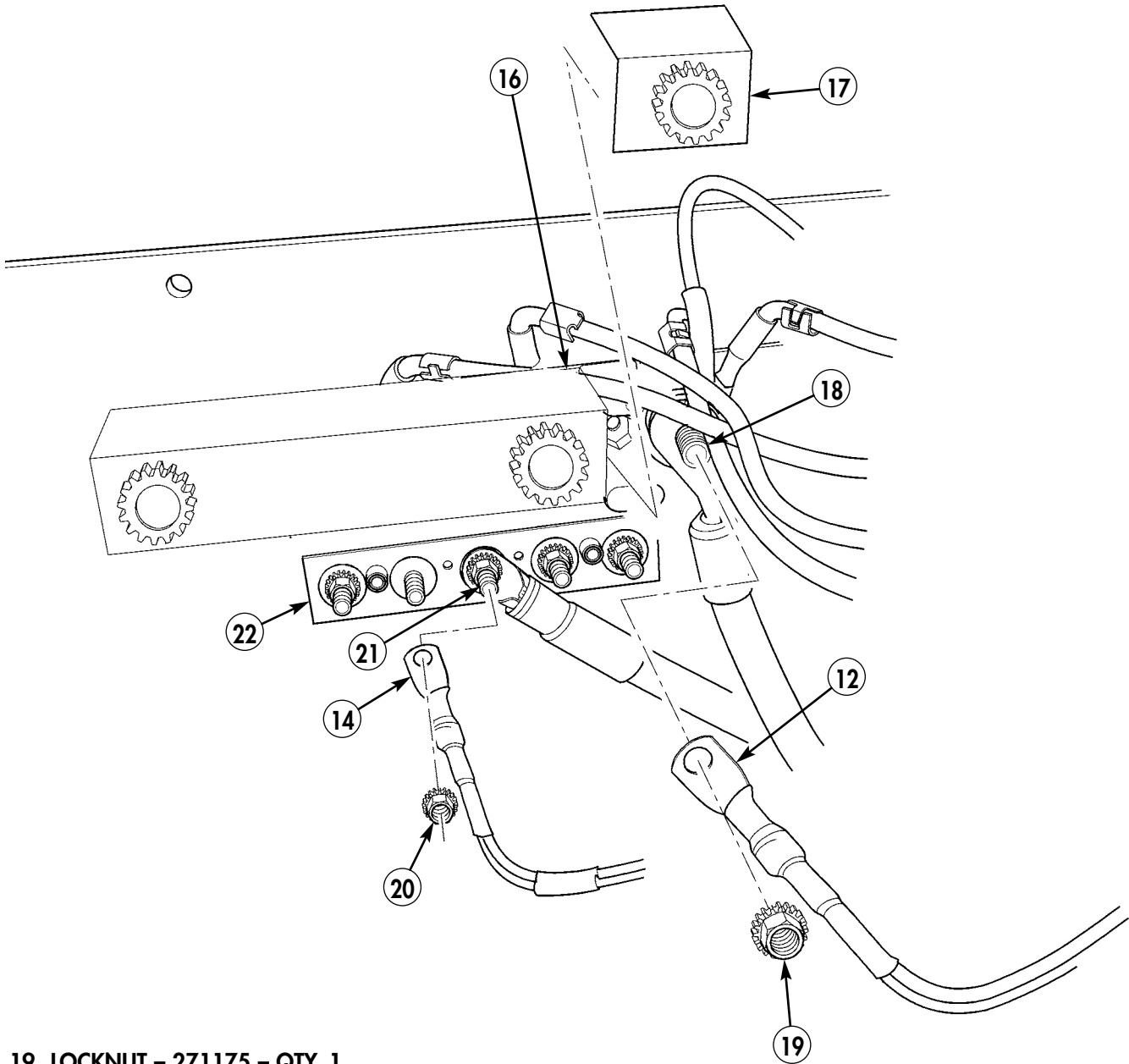

- 19. LOCKNUT - 271175 - QTY. 1
- 20. LOCKNUT - 271169 - QTY. 1

Figure 5-118.

NOTE

Vehicles with serial number SN248732 and above will not have 200 amp power connector.

- 14-14. Install right-side cab enclosure panel (8) on rear of battery box (27) with two existing capscrews (23), lockwashers (24), and existing washers (28).
- 14-15. Secure right side cab enclosure panel (8) to B-beam (26) with three existing capscrews (23), lockwashers (24), and existing washers (25).

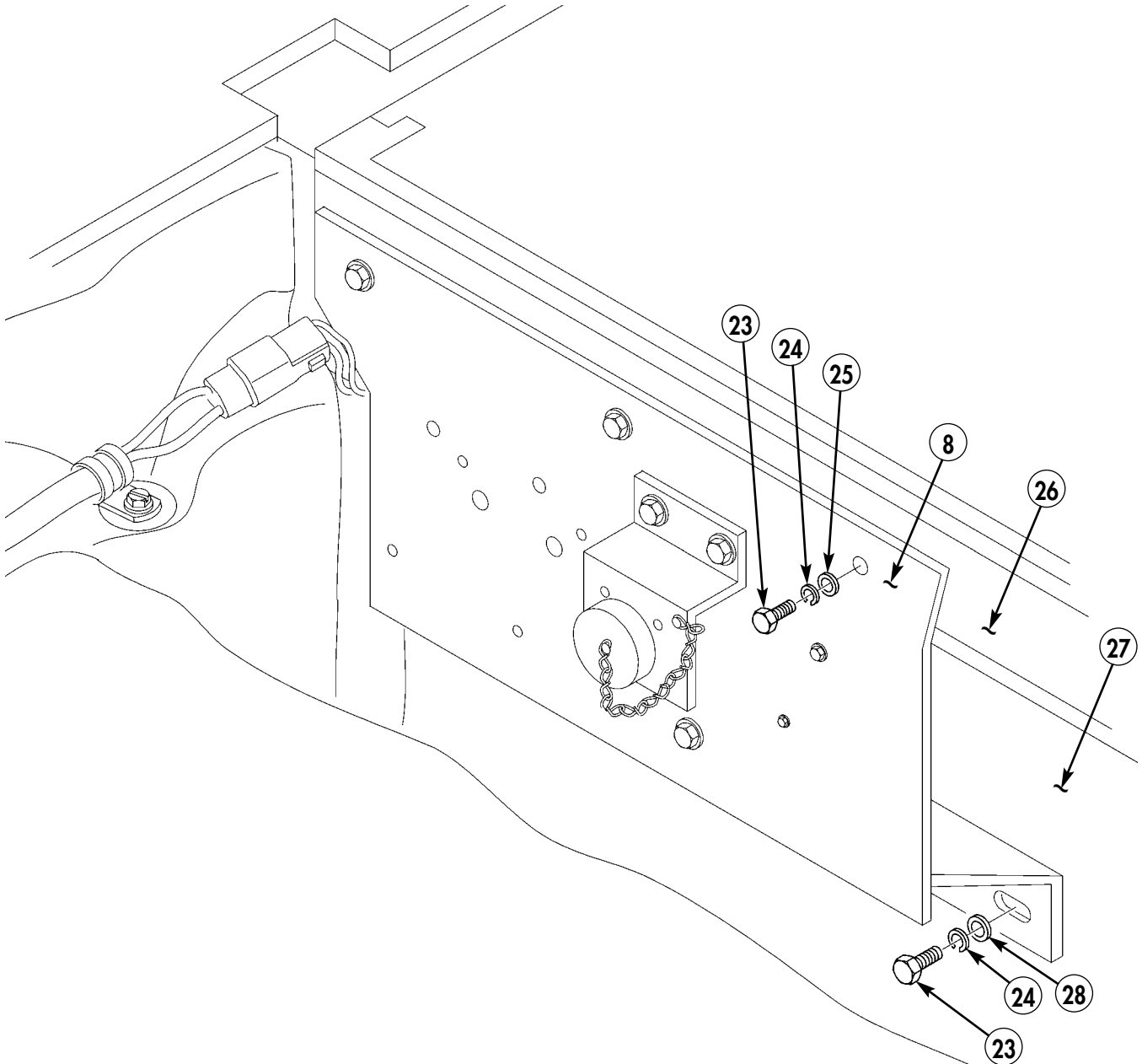

24. LOCKWASHER – MS35338-44 – QTY. 5

Figure 5-119.

By Order of the Secretary of the Army:

GEORGE W. CASEY
General, United States Army
Chief of Staff

Official:

A handwritten signature in black ink that reads "Joyce E. Morrow". The signature is written in a cursive style with a large initial "J" and "M".

JOYCE E. MORROW
Administrative Assistant to the
Secretary of the Army
0725304

Distribution:

To be distributed in accordance with the Initial Distribution Number (IDN) 344826 requirements for TB 9-2320-387-35-8.

RECOMMENDED CHANGES TO PUBLICATIONS AND BLANK FORMS For use of this form, see AR 25-30; the proponent agency is ODISC4.	Use Part II (reverse) for Repair Parts and Special Tools Lists (RPSTL) and Supply Catalogs/Supply Manuals (SC/SM).	DATE: 16 NOV. 2007
---	--	---

TO: (Forward to proponent of publication or form) (include ZIP code) TACOM LIFE CYCLE MANAGEMENT COMMAND ATTN: AMSTA-LC-LPIT/Tech Pubs, 1 Rock Island Arsenal, Rock Island, IL 61299-7630	FROM: (Activity and location) (include ZIP code) Co. B, 1st BN, 2nd Brigade Ft. Hood, TX 76445
--	---

PART I - ALL PUBLICATIONS (EXCEPT RPSTL AND SC/SM) AND BLANK FORMS

PUBLICATION/FORM NUMBER TB 9-2320-387-35-8	DATE 31 OCT. 2007	TITLE TECHNICAL BULLETIN INSTALLATION INSTRUCTIONS
---	--	---

ITEM NO.	PAGE NO.	PARA-GRAPH	LINE NO.*	FIGURE NO.	TABLE NO.	RECOMMENDED CHANGES AND REASON <i>(Provide exact wording of recommended changes, if possible)</i>
----------	----------	------------	-----------	------------	-----------	--

12-7	5-76			5-88		Capscrew part number should be B1821BH025C088N. (Callout #9)
------	------	--	--	------	--	---

SAMPLE

**Reference to line numbers within the paragraph or subparagraph.*

TYPED NAME, GRADE, OR TITLE Pat Smith	TELEPHONE EXCHANGE/AUTOVON, PLUS EXTENSION AV272-4162	SIGNATURE <i>Pat Smith</i>
--	--	--

TO: <i>(Forward direct to addressee listed in publication)</i> TACOM LIFE CYCLE MANAGEMENT COMMAND ATTN: AMSTA-LC-LPIT/Tech Pubs, 1 Rock Island Arsenal, Rock Island, IL 61299-7630	FROM: <i>(Activity and location) (include ZIP code)</i>	DATE: 16 NOV. 2007
--	---	------------------------------

PART II - REPAIR PARTS AND SPECIAL TOOLS LISTS AND SUPPLY CATALOGS/SUPPLY MANUALS

PUBLICATION/FORM NUMBER TB 9-2320-387-35-8	DATE 31 OCT. 2007	TITLE TECHNICAL BULLETIN INSTALLATION INSTRUCTIONS
--	-----------------------------	--

PAGE NO.	COLM NO.	LINE NO.	NATIONAL STOCK NUMBER	REFERENCE NO.	FIGURE NO.	ITEM NO.	TOTAL NO. OF MAJOR ITEMS SUPPORTED	RECOMMENDED ACTION
----------	----------	----------	-----------------------	---------------	------------	----------	------------------------------------	--------------------

SAMPLE

PART III - REMARKS *(Any general remarks or recommendations, or suggestions for improvement of publications and blank forms. Additional blank sheets may be used if more space is needed.)*

--	--	--

TYPED NAME, GRADE, OR TITLE	TELEPHONE EXCHANGE/AUTOVON, PLUS EXTENSION	SIGNATURE
-----------------------------	--	-----------

RECOMMENDED CHANGES TO PUBLICATIONS AND BLANK FORMS For use of this form, see AR 25-30; the proponent agency is ODISC4.				Use Part II (reverse) for Repair Parts and Special Tools Lists (RPSTL) and Supply Catalogs/Supply Manuals (SC/SM).		DATE:
TO: <i>(Forward to proponent of publication or form) (include ZIP code)</i> TACOM LIFE CYCLE MANAGEMENT COMMAND ATTN: AMSTA-LC-LPIT/Tech Pubs, 1 Rock Island Arsenal, Rock Island, IL 61299-7630				FROM: <i>(Activity and location) (include ZIP code)</i>		
PART I - ALL PUBLICATIONS (EXCEPT RPSTL AND SC/SM) AND BLANK FORMS						
PUBLICATION/FORM NUMBER TB 9-2320-387-35-8			DATE 31 OCT. 2007		TITLE TECHNICAL BULLETIN INSTALLATION INSTRUCTIONS	
ITEM NO.	PAGE NO.	PARA-GRAPH	LINE NO.*	FIGURE NO.	TABLE NO.	RECOMMENDED CHANGES AND REASON <i>(Provide exact wording of recommended changes, if possible)</i>
<i>*Reference to line numbers within the paragraph or subparagraph.</i>						
TYPED NAME, GRADE, OR TITLE				TELEPHONE EXCHANGE/AUTOVON, PLUS EXTENSION		SIGNATURE

TO: <i>(Forward direct to addressee listed in publication)</i> TACOM LIFE CYCLE MANAGEMENT COMMAND ATTN: AMSTA-LC-LPIT/Tech Pubs, 1 Rock Island Arsenal, Rock Island, IL 61299-7630	FROM: <i>(Activity and location) (include ZIP code)</i>	DATE:
--	---	-------

PART II - REPAIR PARTS AND SPECIAL TOOLS LISTS AND SUPPLY CATALOGS/SUPPLY MANUALS

PUBLICATION/FORM NUMBER TB 9-2320-387-35-8	DATE 31 OCT. 2007	TITLE TECHNICAL BULLETIN INSTALLATION INSTRUCTIONS
---	--------------------------	--

PAGE NO.	COLM NO.	LINE NO.	NATIONAL STOCK NUMBER	REFERENCE NO.	FIGURE NO.	ITEM NO.	TOTAL NO. OF MAJOR ITEMS SUPPORTED	RECOMMENDED ACTION

PART III - REMARKS *(Any general remarks or recommendations, or suggestions for improvement of publications and blank forms. Additional blank sheets may be used if more space is needed.)*

--

TYPED NAME, GRADE, OR TITLE	TELEPHONE EXCHANGE/AUTOVON, PLUS EXTENSION	SIGNATURE

PIN: 084287-000